

A/C COMPRESSOR CLUTCH CONTROL

2001 Chevrolet Camaro

2000-01 A/C COMPRESSOR CLUTCH CONTROLS
General Motors All Models

NOTE: Metro, Prizm and Tracker, and Saturn are not covered in this article. For A/C compressor clutch diagnosis on Metro, Prizm, Tracker, and Saturn, see appropriate MANUAL A/C-HEATER SYSTEMS article.

MODEL IDENTIFICATION

MODEL IDENTIFICATION (CARS)

Body Code (1)	Model
C	Park Avenue
E	Eldorado
F	Camaro & Firebird
G	Aurora
H	Bonneville & LeSabre
J	Cavalier & Sunfire
K	DeVille & Seville
N	Alero, Grand Am & Malibu
V	Catera
W	Century, Grand Prix, Impala, Intrigue, Lumina, Monte Carlo & Regal
Y	Corvette

(1) - Vehicle body code is fourth character of VIN.

MODEL IDENTIFICATION (LIGHT TRUCKS & VANS)

Series (1)	Model(s)
A	FWD Aztek
B	AWD Aztek
C	2WD - Pickup, Sierra, Suburban, Tahoe, Silverado & Yukon
G	Express & Savana
K	4WD - Pickup, Escalade, Sierra, Suburban, Tahoe, Silverado & Yukon
L	AWD Astro & Safari
M	2WD Astro & Safari
S	2WD - Blazer, Jimmy, Pickup & Sonoma
T	4WD - Blazer, Bravada, Jimmy, Pickup & Sonoma
U	Montana, Silhouette & Venture

(1) - Vehicle series code is fifth character of VIN.

DESCRIPTION & OPERATION

A/C COMPRESSOR CLUTCH CONTROLS (CARS)

To provide improved idle quality, improved Wide Open Throttle (WOT) performance and A/C system protection, the compressor clutch is controlled by PCM/ECM.

For proper control of cooling fans, compressor clutch, and Idle Air Control (IAC) valve, a refrigerant pressure sensor is used.

The PCM/ECM uses signals provided by sensor to monitor high and low side refrigerant pressures. If PCM/ECM detects a fault in refrigerant pressure circuit, compressor clutch will be disabled.

The A/C clutch relay is controlled by PCM/ECM. This allows PCM/ECM to raise idle speed before engaging compressor clutch, or disable compressor clutch during WOT, high engine RPM, high power steering loads, and hot engine restarts. The PCM/ECM also disables compressor clutch if coolant temperature becomes excessive.

NOTE: This article ONLY contains those testing procedures required to test A/C compressor clutch control circuit. Other diagnostic information may be referenced while performing A/C compressor clutch control diagnosis. For additional information, see appropriate SELF-DIAGNOSTICS article in ENGINE PERFORMANCE.

A/C CLUTCH RELAY LOCATION (CARS)

Application	Location
C Body	Right Front Of Engine Compartment, In Fuse/Relay Block
K Body	In Underhood Fuse/Relay Block, On Right Side Of Engine Compartment
E Body	In Underhood Fuse/Relay Block, On Left Side Of Engine Compartment
F Body	In Underhood Electrical Center, In Left Front Of Engine Compartment
G Body	In Underhood Relay Center, On Right Side Of Engine Compartment
H Body	In Underhood Fuse Block, At Right Front Of Engine Compartment
J Body	In Underhood Fuse/Relay Block, At Left Front Of Engine Compartment
N Body	In Underhood Fuse/Relay Block, At Left Side Of Engine Compartment
V Body	Left Front of Engine Compartment, In ECM Housing
W Body	In Underhood Electrical Center, On Right Side Of Engine Compartment
Y Body	In Underhood Electrical Center, In Front Of Battery

A/C COMPRESSOR CLUTCH CONTROLS (LIGHT TRUCKS & VANS)

FWD Vans

To provide improved idle quality, maintain Wide Open Throttle (WOT) performance and provide A/C system protection, compressor clutch is controlled by PCM.

The A/C clutch relay is controlled by PCM according to information received from A/C pressure sensor and various other sensors. This allows the PCM to raise idle speed before engaging compressor clutch. PCM will disable compressor clutch during WOT, when refrigerant pressure is incorrect or if coolant temperature exceeds a predetermined value. The PCM inhibits compressor clutch operation when engine speed is greater than 4500 RPM for 5 seconds, or when throttle angle exceeds 90 percent.

RWD Trucks & Vans

The A/C clutch relay is controlled by PCM/VCM. The PCM/VCM improves idle quality by delaying compressor clutch engagement until idle speed is increased, or disengages compressor clutch when idle

speed is too low. Compressor clutch is cycled by PCM/VCM. The PCM/VCM smooths cycling of compressor clutch by adding fuel the instant compressor clutch is applied.

A/C CLUTCH RELAY LOCATION (LIGHT TRUCKS & VANS)

Application	Location
A & B Series	In Underhood Fuse/Relay Block, On Right Side Above Battery
C & K Series	In Underhood Fuse/Relay Center, On Left Side Of Engine Compartment
S & T Series	In Underhood Fuse Block, On Left Side Of Engine Compartment
G Series	In Underhood Fuse/Relay Center, Left Front Of Engine Compartment
L & M Series	In Underhood Fuse/Relay Center, Left Side Of Engine Compartment
U Body	In Underhood Accessory Wiring Junction Block

A/C CLUTCH CIRCUIT DIAGNOSIS (CARS)

To help save diagnostic time, ALWAYS check for blown fuses or fusible links before proceeding with diagnosis. If fuses are blown, locate and repair short circuit before replacing fuses.

Ensure all related relay and wire harness connections are clean and tight. Repair as necessary. See WIRING DIAGRAMS.

NOTE: Vehicles may be equipped with a PCM using an Electronically Erasable Programmable Read Only Memory (EEPROM). When replacing PCM, the new PCM must be programmed.

2.2L & 2.4L: CAVALIER & SUNFIRE (2000)

NOTE: For circuit, wire color and terminal identification, see WIRING DIAGRAMS. Also see WIRING DIAGRAMS in appropriate MANUAL or AUTOMATIC A/C HEATER SYSTEMS article.

Description

Powertrain Control Module (PCM) receives an A/C request signal from Instrument Panel Cluster (IPC) over UART serial data line. When A/C is requested, the PCM provides a ground path to A/C clutch relay control circuit. When relay circuit is grounded, A/C clutch relay is energized. PCM delays grounding relay circuit for .3 second. This allows PCM to adjust engine idle RPM for additional load.

PCM will temporarily de-energize A/C clutch relay when one or more of the following conditions occur:

- * A hot engine restart.
- * Wide open throttle (TPS position over 90 percent).
- * If engine RPM is greater than 6000 RPM.
- * During Idle Air Control (IAC) valve reset

A/C clutch relay will remain de-energized when one or both of the following conditions occur:

- * DTC P0530 or U1016 are set.
- * When there is no A/C request signal to PCM.

For additional trouble shooting information, go to MANUAL A/C-HEATER SYSTEMS - CAVALIER & SUNFIRE article.

Diagnostic System Check

- 1) Install scan tool. If scan tool powers up, go to next step. If scan tool does not power up, see SCAN TOOL DOES NOT POWER UP in appropriate BODY CONTROL MODULES article.
- 2) Turn ignition on, engine off. Try to establish scan tool communication with Body Control Module (BCM) and Powertrain Control Module (PCM). If communication with both modules is established, go to next step. If communication with both modules is not established, see SCAN TOOL DOES NOT COMMUNICATE WITH CLASS 2 DEVICE in appropriate BODY CONTROL MODULES article.
- 3) Select display DTC function for each module. Record all displayed DTCs, status of displayed DTCs and which module set DTC. If DTCs are displayed, go to next step. If no DTCs are displayed, see DIAGNOSIS.
- 4) If scan tool displays any DTCs beginning with "B", see appropriate SELF-DIAGNOSTICS article in BODY CONTROL MODULES. If scan tool displays DTCs beginning with "P", see appropriate SELF-DIAGNOSTICS article in ENGINE PERFORMANCE. If scan tool displays DTCs beginning with "U", see SCAN TOOL DOES NOT COMMUNICATE WITH CLASS 2 DEVICE in appropriate BODY CONTROL MODULES article.

Diagnosis

- 1) If diagnostic system check has not been performed, see DIAGNOSTIC SYSTEM CHECK. If diagnostic system check has been performed, go to next step.
- 2) Install scan tool. Check for any DTCs that may be set. If DTC P0530 or U1016 are set, see appropriate SELF-DIAGNOSTICS article in ENGINE PERFORMANCE. If no DTCs are set, go to next step.
- 3) If A/C compressor clutch is engaged, go to next step. If A/C compressor clutch is not engaged, go to step 5).
- 4) Remove A/C clutch relay. If A/C compressor clutch disengages, go to step 6). If A/C compressor clutch does not disengage, go to step 7).
- 5) Start engine and allow it to reach normal operating temperature. Cycle A/C on and off at control panel. If A/C compressor clutch cycles on and off, go to step 8). If A/C compressor clutch does not cycle on and off, go to step 9).
- 6) Using a test light connected to battery voltage, probe A/C clutch relay control circuit terminal (Dark Green/White wire) at A/C clutch relay connector. See WIRING DIAGRAMS. If test light comes on, go to step 20). If test light does not come on, go to step 30).
- 7) Disconnect A/C compressor clutch harness connector. If A/C compressor clutch disengages, go to step 21). If A/C compressor clutch does not disengage, go to step 32).
- 8) Turn ignition switch to OFF position. Install A/C manifold gauge set. Compare high-side pressure reading on gauge with scan tool reading. If readings are within 20 psi (1.4 kg/cm²) of each other, go to step 36). If readings are not as specified, go to step 10).
- 9) While observing scan tool, turn A/C on, then off. If scan tool indicates A/C was requested, then not requested, go to step 11). If operation is not as specified, go to step 12).
- 10) Disconnect A/C refrigerant pressure sensor electrical connector. Connect DVOM between battery voltage and A/C refrigerant pressure sensor ground circuit (Black wire). If DVOM reads battery voltage, go to step 31). If DVOM does not read battery voltage, go to step 22).
- 11) Turn engine off, leaving ignition switch in ON position. If A/C high side value is 40-430 psi (2.8-30.2 kg/cm²), go to step 13). If A/C high side value is not 40-430 psi (2.8-30.2 kg/cm²) go to step 14).

12) Connect test light between ground and A/C selector switch input circuit (Light Green/Black wire) to instrument cluster. Cycle A/C selector switch on and off. If test light turns on and off when A/C selector switch is cycled, go to step 34). If test light does not turn on and off when A/C selector switch is cycled, go to step 23).

13) Remove A/C relay. Using a test light connected to ground, probe ignition feed circuit (Pink wire) and battery feed circuit (Orange wire). If test light is on for both circuits, go to step 15). If test light is off for both circuits, go to step 24).

14) Install an A/C manifold gauge set. Observe A/C high side pressure on scan tool and manifold gauge set. If A/C high side pressure is within 20 psi (1.4 kg/cm²) of each other, see DIAGNOSTIC SYSTEM CHECK. If A/C high side pressure is not within 20 psi (1.4 kg/cm²) of each other, go to step 31).

15) Connect a fused jumper between A/C relay ignition feed terminal No. 85 (Pink wire) and compressor clutch feed terminal No. 87 (Dark Green wire). If A/C compressor clutch engages, go to next step. If A/C compressor clutch does not engage, go to step 17).

16) Remove fused jumper wire. Start engine. Ensure A/C is selected on, then command A/C compressor clutch relay on using scan tool. Using a test light connected to battery voltage, probe A/C compressor clutch relay control terminal No. 86 (Dark Green/White wire). If test light is on, go to step 30). If test light is off, go to step 18).

17) Disconnect A/C compressor clutch electrical connector. Leave fused jumper connected. Using a test light connected to ground, probe A/C compressor clutch ignition feed circuit (Dark Green wire). If test light is on, go to step 19). If test light is off, go to step 26).

18) Turn ignition switch to ON position, with engine OFF. Using a test light connected to ground, probe compressor clutch relay control terminal No. 86 (Dark Green/White wire). If test light is on, go to step 27). If test light is off, go to step 28).

19) Using a test light connected to battery voltage, probe A/C compressor clutch ground circuit (Black wire) at A/C compressor clutch connector. If test light is on, go to step 33). If test light is off, go to step 29).

20) Check A/C compressor clutch relay control circuit (Dark Green/White wire) for short to ground. If problem was found, repair as necessary. After repairs, go to step 36). If problem was not found, go to step 35).

21) Repair short to battery voltage in A/C compressor clutch ignition feed circuit (Dark Green wire). After repairs, go to step 36).

22) Check A/C refrigerant pressure sensor ground (Black wire) for open or poor connections. If problem was found, repair as necessary. After repairs, go to step 36). If problem was not found, go to step 35).

23) Repair signal from A/C selector switch. After repairs, go to step 36).

24) If test light was not on at A/C relay battery feed terminal No. 30 or ignition feed terminal No. 85, check short to ground in A/C compressor clutch ignition feed circuit (Dark Green wire), A/C compressor clutch diode, battery feed circuit (Orange wire) and ignition feed circuit (Pink wire). If problem was found, repair as necessary. After repairs, go to step 36). If problem was not found, go to next step.

25) Turn ignition switch to OFF position. Check for open in A/C compressor clutch relay battery feed circuit (Orange wire) and ignition feed circuit (Pink wire). If problem was found, repair as necessary. After repairs, go to step 36). If problem was not found, go to step 30).

26) Turn ignition switch to OFF position. Repair open in A/C

compressor clutch ignition feed circuit (Dark Green wire). After repairs, go to step 36).

27) Check A/C compressor clutch relay control circuit (Dark Green/White wire) for short to voltage. If problem was found, repair as necessary. After repairs, go to step 36). If problem was not found, go to step 35).

28) Check A/C compressor clutch relay control circuit (Dark Green/White wire) for open or poor connections. If problem was found, repair as necessary. After repairs, go to step 36). If problem was not found, go to step 35).

29) Repair open or poor connections in A/C compressor clutch ground circuit (Black wire). After repairs, go to step 36).

30) Turn ignition switch to OFF position. Check for poor connections at A/C relay. If connections are okay, replace A/C compressor clutch relay. After repairs, go to step 36).

31) Check for poor connections at A/C refrigerant pressure sensor. If connections are okay, replace A/C refrigerant pressure sensor. After repairs, go to step 36).

32) Replace malfunctioning A/C compressor clutch assembly. See appropriate COMPRESSOR SERVICING article in GENERAL SERVICING. After repairs, go to step 36).

33) Turn ignition switch to OFF position. Check for poor connections at A/C compressor clutch coil. If connections are okay, replace A/C compressor clutch coil. See appropriate COMPRESSOR SERVICING article in GENERAL SERVICING. After repairs, go to step 36).

34) See SELF-DIAGNOSTIC SYSTEM in appropriate ANALOG INSTRUMENT PANELS article. After repairs, go to step 36).

35) Turn ignition switch to OFF position. Replace PCM. See appropriate REMOVAL, OVERHAUL & INSTALLATION article in ENGINE PERFORMANCE. After repairs, go to next step.

36) Start engine. Idle engine. Cycle A/C selector switch on and off. If A/C compressor clutch cycles on and off, system is okay.

Diagnostic Aids

If DTCs P0530 or U1060 are set, diagnose them before proceeding. See appropriate SELF-DIAGNOSTICS article in ENGINE PERFORMANCE. If problem is insufficient cooling, check cooling fans for proper operation. See ELECTRIC COOLING FANS - ALL MODELS article. If cooling fans operate correctly, diagnose manual A/C-heater system. See MANUAL A/C-HEATER SYSTEMS - CAVALIER & SUNFIRE article.

An A/C refrigerant pressure less than 43 psi (3.0 kg/cm²), or greater than 428 psi (30.1 kg/cm²), will cause PCM to disable compressor clutch. With engine running and A/C on, use scan tool to monitor A/C high-side pressure for 2 minutes. If pressure goes out of range, diagnose manual A/C-heater system.

2.2L & 2.4L: CAVALIER & SUNFIRE (2001)

NOTE: For circuit, wire color and terminal identification, see WIRING DIAGRAMS. Also see WIRING DIAGRAMS in appropriate MANUAL or AUTOMATIC A/C HEATER SYSTEMS article.

Description

Powertrain Control Module (PCM) receives an A/C request signal from Body Control Module (BCM) over UART serial data line. When A/C is requested, the PCM provides a ground path to A/C clutch relay control circuit. When relay circuit is grounded, A/C clutch relay is energized. PCM delays grounding relay circuit for .3 second. This allows PCM to adjust engine idle RPM for additional load.

PCM will temporarily de-energize A/C clutch relay when one or more of the following conditions occur:

- * A hot engine restart.
- * Wide open throttle (TPS position over 90 percent).
- * If engine RPM is greater than 6000 RPM.
- * During Idle Air Control (IAC) valve reset

A/C clutch relay will remain de-energized when one or both of the following conditions occur:

- * DTC P0530 or U1016 are set.
- * When there is no A/C request signal to PCM.

For additional trouble shooting information, go to MANUAL A/C-HEATER SYSTEMS - CAVALIER & SUNFIRE article.

Diagnostic System Check

- 1) Install scan tool. If scan tool powers up, go to next step. If scan tool does not power up, see SCAN TOOL DOES NOT POWER UP in appropriate BODY CONTROL MODULES article.
- 2) Turn ignition on, engine off. Try to establish scan tool communication with Powertrain Control Module (PCM). If communication with PCM is established, go to next step. If communication with PCM is not established, see SCAN TOOL DOES NOT COMMUNICATE WITH CLASS 2 DEVICE in appropriate BODY CONTROL MODULES article.
- 3) Select display DTC function for PCM. Record all displayed DTCs and status of displayed DTCs. If DTCs are displayed, go to next step. If no DTCs are displayed, see COMPRESSOR CLUTCH DOES NOT ENGAGE or COMPRESSOR CLUTCH DOES NOT DISENGAGE.
- 4) If scan tool does not display DTCs beginning with "U", see appropriate SELF-DIAGNOSTICS article in ENGINE PERFORMANCE. If scan tool displays DTCs beginning with "U", see SCAN TOOL DOES NOT COMMUNICATE WITH CLASS 2 DEVICE in appropriate BODY CONTROL MODULES article.

Compressor Clutch Does Not Engage

- 1) If diagnostic system check has not been performed, see DIAGNOSTIC SYSTEM CHECK. If diagnostic system check has been performed, go to next step.
- 2) Ensure outside air temperature is greater than 38°F (3°C). Start engine. Turn blower motor switch to maximum speed position. Turn A/C request switch to ON position. Turn air temperature switch to coldest position. Cycle mode switch through each position except off. If A/C compressor operates in each mode position, problem is intermittent. If A/C compressor does not operate in each mode position, go to next step.
- 3) Park vehicle inside or in shade. Open windows in order to ventilate interior of vehicle. Turn ignition switch to OFF position. Install Refrigerant Station (J 43600 ACR 2000). Record outside air temperature at vehicle. Record readings of low and high side STATIC pressures. Compare pressure values with specifications for ambient air temperature. See PRESSURE-TEMPERATURE RELATIONSHIP article in GENERAL SERVICING. If pressure values are within specification for ambient air temperature and within 15 psi (1.1 kg/cm²) of each other, go to next step. If pressure values are not within specification for ambient air temperature or within 15 psi (1.1 kg/cm²) of each other, see LEAK TESTING article in GENERAL SERVICING.
- 4) Turn ignition switch to ON position, with engine off. Using scan tool, observe A/C high side pressure sensor parameter in powertrain data list. Compare A/C high side pressure on scan tool to high side pressure value on refrigerant station. If high side pressure values are within 15 psi (1.1 kg/cm²), go to next step. If high side pressure values are not within 15 psi (1.1 kg/cm²), go to step 18).
- 5) If HVAC control assembly is inoperative, go to step 9). If

HVAC control assembly is not inoperative, go to next step.

6) Start engine. Using scan tool, observe A/C request parameter in powertrain data list 2. Turn blower motor switch to maximum position. Turn mode switch to recirculation position. If scan tool indicates A/C request parameter is YES, go to next step. If scan tool indicates A/C request parameter is not YES, go to step 11).

7) Using scan tool, observe A/C relay commanded parameter in powertrain data list 2. If scan tool indicates A/C relay commanded parameter is ON, go to next step. If scan tool does not indicate A/C relay commanded parameter is ON, go to step 28).

8) Using scan tool, command A/C compressor clutch relay on and off. If A/C compressor clutch relay turns on and off with each command, go to step 12). If A/C compressor clutch relay does not turn on and off with each command, go to step 14).

9) Test ignition voltage circuit (Brown wire) to HVAC control assembly for short to ground, high resistance, or open. If problem was found, repair as necessary. After repairs, go to step 35). If problem was not found, go to next step.

10) Check ground circuit (Black wire) to HVAC control assembly for open. If problem was found, repair as necessary. After repairs, go to step 35). If problem was not found, go to step 26).

11) Start engine. Turn mode switch to MAX A/C position. Using test light connected to ground, probe A/C request signal circuit (Light Green/Black wire) at Body Control Module (BCM). If test light is on, go to step 27). If test light is off, go to step 16).

12) Turn ignition switch to OFF position. Disconnect A/C compressor clutch relay. Using a test light connected to ground, probe switch side voltage supply circuit (Orange wire) of A/C compressor clutch relay connector. If test light is on, go to next step. If test light is off, go to step 21).

13) Connect fused jumper (10 amp) between switch side voltage circuit (Orange wire) of A/C compressor clutch relay connector and A/C compressor clutch supply voltage circuit (Dark Green wire) of A/C compressor clutch relay connector. Turn ignition switch to ON position, with engine off. If A/C compressor clutch engages, go to step 24). If A/C compressor clutch does not engage, go to step 17).

14) Turn ignition switch to OFF position. Disconnect A/C compressor clutch relay. Turn ignition switch to ON position, with engine off. Using a test light connected to ground, probe coil side voltage supply circuit (Pink wire) of A/C compressor clutch relay connector. If test light is on, go to next step. If test light is off, go to step 20).

15) Connect test light between control circuit (Dark Green/White wire) of A/C compressor clutch relay connector and coil side voltage supply circuit (Pink wire) of A/C compressor clutch relay connector. Using scan tool, command A/C compressor clutch relay on and off. If test light turns on and off with each command, go to step 24). If test light does not turn on and off with each command, go to step 22).

16) Check A/C request signal circuit (Light Green/Black wire) for short to ground, high resistance or open. If problem was found, repair as necessary. After repairs, go to step 35). If problem was not found, go to step 26).

17) Check A/C compressor clutch supply voltage circuit (Dark Green wire) at A/C compressor clutch for short to ground, high resistance or open. If problem was found, repair as necessary. After repairs, go to step 35). If problem was not found, go to step 19).

18) Check ground circuit (Black wire) of A/C pressure sensor for open. If problem was found, repair as necessary. After repairs, go to step 35). If problem was not found, go to step 23).

19) Check ground circuit (Black wire) of A/C compressor clutch for high resistance or open. If problem was found, repair as necessary. After repairs, go to step 35). If problem was not found, go

to step 25).

20) Repair coil side voltage supply circuit (Pink wire) of A/C compressor clutch relay. After repairs, go to step 35).

21) Repair switch side voltage supply circuit (Orange wire) of A/C compressor clutch relay. After repairs, go to step 35).

22) Check control circuit (Dark Green/White wire) of A/C compressor clutch relay for open, or short to ground. If problem was found, repair as necessary. After repairs, go to step 35). If problem was not found, go to step 28).

23) Check A/C high pressure sensor connector for poor connections. If problem was found, repair as necessary. After repairs, go to step 35). If problem was not found, go to step 29).

24) Check A/C compressor clutch relay connector for poor connections. If problem was found, repair as necessary. After repairs, go to step 35). If problem was not found, go to step 30).

25) Check A/C compressor clutch coil connector for poor connections. If problem was found, repair as necessary. After repairs, go to step 35). If problem was not found, go to step 31).

26) Check HVAC control assembly connector for poor connections. If problem was found, repair as necessary. After repairs, go to step 35). If problem was not found, go to step 32).

27) Check BCM connectors for poor connections. If problem was found, repair as necessary. After repairs, go to step 35). If problem was not found, go to step 33).

28) Check PCM connectors for poor connections. If problem was found, repair as necessary. After repairs, go to step 35). If problem was not found, go to step 34).

29) Replace A/C high pressure switch. After repairs, go to step 35).

30) Replace A/C compressor clutch relay. After repairs, go to step 35).

31) Replace A/C compressor clutch coil. See appropriate COMPRESSOR SERVICING article in GENERAL SERVICING. After repairs, go to step 35).

32) Replace HVAC control assembly. See REMOVAL & INSTALLATION in appropriate MANUAL A/C-HEATER SYSTEMS article. After repairs, go to step 35).

33) Replace BCM. See appropriate BODY CONTROL MODULES article in ACCESSORIES & EQUIPMENT. After repairs, go to step 35).

34) Replace PCM. See appropriate REMOVAL, OVERHAUL & INSTALLATION article in ENGINE PERFORMANCE. After repairs, go to next step.

35) Operate system to verify repair.

Compressor Clutch Does Not Disengage

1) If diagnostic system check has not been performed, see DIAGNOSTIC SYSTEM CHECK. If diagnostic system check has been performed, go to next step.

2) Start engine. Turn mode switch to OFF position. Place A/C request switch in OFF position. If A/C compressor operates, go to next step. If A/C compressor does not operate, problem is intermittent.

3) Using scan tool, observe A/C REQUEST parameter in POWERTRAIN DATA LIST 2. If scan tool indicates A/C REQUEST parameter is NO, go to next step. If scan tool does not indicate A/C REQUEST parameter is NO, go to step 6).

4) Using scan tool, observe A/C RELAY COMMANDED parameter in POWERTRAIN DATA LIST 2. If scan tool indicates A/C RELAY COMMANDED parameter is OFF, go to next step. If scan tool does not indicate A/C RELAY COMMAND parameter is OFF, go to step 14).

5) Check control circuit (Dark Green/White wire) of A/C compressor clutch relay for short to ground. If problem was found, repair as necessary. After repairs, go to step 20). If problem was not found, go to step 7).

6) Turn ignition switch to ON position. Turn mode switch to OFF position. Using test light connected to ground, probe A/C request signal circuit (Light Green/Black wire) at BCM. If test light is on, go to step 9). If test light is off, go to step 13).

7) Remove A/C compressor clutch relay. If A/C compressor clutch turns off, go to step 10). If A/C compressor clutch does not turn off, go to next step.

8) Check A/C compressor clutch voltage supply circuit (Dark Green wire) for short to voltage. If problem was found, repair as necessary. After repairs, go to step 20). If problem was not found, go to step 11).

9) Check A/C request signal circuit (Light Green/Black wire) for short to voltage. If problem was found, repair as necessary. After repairs, go to step 20). If problem was not found, go to step 12).

10) Check A/C compressor clutch relay connector for poor connections. If problem was found, repair as necessary. After repairs, go to step 20). If problem was not found, go to step 15).

11) Check A/C compressor clutch connector for poor connections. If problem was found, repair as necessary. After repairs, go to step 20). If problem was not found, go to step 16).

12) Check HVAC control assembly connector for poor connections. If problem was found, repair as necessary. After repairs, go to step 20). If problem was not found, go to step 17).

13) Check BCM connectors for poor connections. If problem was found, repair as necessary. After repairs, go to step 20). If problem was not found, go to step 18).

14) Check PCM connectors for poor connections. If problem was found, repair as necessary. After repairs, go to step 20). If problem was not found, go to step 19).

15) Replace A/C compressor clutch relay. After repairs, go to step 20).

16) Replace A/C compressor clutch. See appropriate COMPRESSOR SERVICING article in GENERAL SERVICING. After repairs, go to step 20).

17) Replace HVAC control assembly. See REMOVAL & INSTALLATION in appropriate MANUAL A/C-HEATER SYSTEMS article. After repairs, go to step 20).

18) Replace BCM. See appropriate BODY CONTROL MODULES article in ACCESSORIES & EQUIPMENT. After repairs, go to step 20).

19) Replace PCM. See appropriate REMOVAL, OVERHAUL & INSTALLATION article in ENGINE PERFORMANCE. After repairs, go to next step.

20) Operate system to verify repair.

2.4L, 3.1L & 3.4L: ALERO, GRAND AM & MALIBU

NOTE: For circuit, wire color and terminal identification, see WIRING DIAGRAMS. Also see WIRING DIAGRAMS in appropriate MANUAL or AUTOMATIC A/C HEATER SYSTEMS article.

Description

Powertrain Control Module (PCM) receives an A/C request signal from Body Control Module (BCM) over Class 2 serial data line. When A/C is requested, PCM provides a ground path to A/C clutch relay control circuit. When relay circuit is grounded, A/C clutch relay is energized. The PCM delays grounding relay circuit for .3 second. This allows PCM to adjust engine idle RPM for additional load.

The PCM will temporarily de-energize A/C clutch relay when one or more of the following conditions occur:

- * A hot engine restart.
- * Wide open throttle (TPS position over 90 percent).
- * If engine RPM is greater than 6000 RPM.

- * During Idle Air Control (IAC) valve reset.

A/C clutch relay will remain de-energized when one or both of the following conditions occur:

- * DTC P0530 or U1016 are set.
- * When there is no A/C request signal to PCM.

For additional trouble shooting information, go to appropriate MANUAL A/C-HEATER SYSTEMS article.

Diagnostic System Check

1) Install scan tool. If scan tool powers up, go to next step. If scan tool does not power up, see SCAN TOOL DOES NOT POWER UP in appropriate BODY CONTROL MODULES article.

2) Turn ignition on, engine off. Try to establish scan tool communication with Powertrain Control Module (PCM). If communication with PCM is established, go to next step. If communication with PCM is not established, see SCAN TOOL DOES NOT COMMUNICATE WITH CLASS 2 DEVICE in appropriate BODY CONTROL MODULES article.

3) Select display DTC function for PCM. Record all displayed DTCs and status of displayed DTCs. If DTCs are displayed, go to next step. If no DTCs are displayed, see COMPRESSOR CLUTCH DOES NOT ENGAGE or COMPRESSOR CLUTCH DOES NOT DISENGAGE.

4) If scan tool does not display DTCs beginning with "U", see appropriate SELF-DIAGNOSTICS article in ENGINE PERFORMANCE. If scan tool displays DTCs beginning with "U", see SCAN TOOL DOES NOT COMMUNICATE WITH CLASS 2 DEVICE in appropriate BODY CONTROL MODULES article.

Compressor Clutch Does Not Engage

1) If diagnostic system check has not been performed, see DIAGNOSTIC SYSTEM CHECK. If diagnostic system check has been performed, go to next step.

2) Ensure outside air temperature is greater than 38°F (3°C). Start engine. Turn blower motor switch to maximum speed position. Turn A/C request switch to ON position. Turn air temperature switch to coldest position. If A/C compressor operates, problem is intermittent. If A/C compressor does not operate, go to next step.

3) Park vehicle inside or in shade. Open windows in order to ventilate interior of vehicle. If A/C system was operating, then allow A/C system to equalize for about 2 minutes. Turn ignition switch to OFF position. Install Refrigerant Station (J 43600 ACR 2000). Record outside air temperature at vehicle. Record readings of low and high side static pressures. Compare pressure values with specifications for ambient air temperature. See PRESSURE-TEMPERATURE RELATIONSHIP article in GENERAL SERVICING. If pressure values are within specification for ambient air temperature and within 15 psi (1.1 kg/cm²) of each other, go to next step. If pressure values are not within specification for ambient air temperature or within 15 psi (1.1 kg/cm²) of each other, see LEAK TESTING article in GENERAL SERVICING.

4) Turn ignition switch to ON position, with engine off. Using scan tool, observe A/C high side pressure sensor parameter in powertrain data list. Compare A/C high side pressure on scan tool to high side pressure value on refrigerant station. If high side pressure values are within 15 psi (1.1 kg/cm²), go to next step. If high side pressure values are not within 15 psi (1.1 kg/cm²), go to step 18).

5) If HVAC control assembly is inoperative, go to step 9). If HVAC control assembly is not inoperative, go to next step.

6) Start engine. Using scan tool, observe A/C request parameter in BCM data list 2. Turn blower motor switch to maximum position. Turn mode switch to VENT position. Place A/C request switch in ON position. If scan tool indicates A/C request parameter is YES,

go to next step. If scan tool indicates A/C request parameter is not YES, go to step 11).

7) Using scan tool, observe A/C relay commanded parameter in powertrain data list 2. If scan tool indicates A/C relay commanded parameter is ON, go to next step. If scan tool does not indicate A/C relay commanded parameter is ON, go to step 28).

8) Using scan tool, command A/C compressor clutch relay on and off. If A/C compressor clutch relay turns on and off with each command, go to step 12). If A/C compressor clutch relay does not turn on and off with each command, go to step 14).

9) Test ignition voltage circuit (Brown wire) to HVAC control assembly for short to ground, high resistance, or open. If problem was found, repair as necessary. After repairs, go to step 35). If problem was not found, go to next step.

10) Check ground circuit (Black wire) to HVAC control assembly for open. If problem was found, repair as necessary. After repairs, go to step 35). If problem was not found, go to step 26).

11) Start engine. Place A/C request switch in ON position. Measure voltage between A/C request circuit (Light Green wire) at BCM and ground. If battery voltage is present, go to step 27). If battery voltage is not present, go to step 16).

12) Turn ignition switch to OFF position. Disconnect A/C compressor clutch relay. Using a test light connected to ground, probe switch side voltage supply circuit of A/C compressor clutch relay connector. If test light is on, go to next step. If test light is off, go to step 21).

13) Connect fused jumper (10 amp) between switch side voltage circuit of A/C compressor clutch relay connector and A/C compressor clutch supply voltage circuit (Dark Green wire) of A/C compressor clutch relay connector. Turn ignition switch to ON position, with engine off. If A/C compressor clutch engages, go to step 24). If A/C compressor clutch does not engage, go to step 17).

14) Turn ignition switch to OFF position. Disconnect A/C compressor clutch relay. Turn ignition switch to ON position, with engine off. Using a test light connected to ground, probe coil side voltage supply circuit of A/C compressor clutch relay connector. If test light is on, go to next step. If test light is off, go to step 20).

15) Connect test light between control circuit (Dark Green/White wire) of A/C compressor clutch relay connector and coil side voltage supply circuit of A/C compressor clutch relay connector. Using scan tool, command A/C compressor clutch relay on and off. If test light turns on and off with each command, go to step 24). If test light does not turn on and off with each command, go to step 22).

16) Check A/C request signal circuit (Light Green wire) for short to ground, high resistance or open. If problem was found, repair as necessary. After repairs, go to step 35). If problem was not found, go to step 26).

17) Check A/C compressor clutch supply voltage circuit (Dark Green wire) at A/C compressor clutch for short to ground, high resistance or open. If problem was found, repair as necessary. After repairs, go to step 35). If problem was not found, go to step 19).

18) Check ground circuit (Black wire) of A/C pressure sensor for open. If problem was found, repair as necessary. After repairs, go to step 35). If problem was not found, go to step 23).

19) Check ground circuit (Gray wire and Black wire) of A/C compressor clutch for high resistance or open. If problem was found, repair as necessary. After repairs, go to step 35). If problem was not found, go to step 25).

20) Repair coil side voltage supply circuit of A/C compressor clutch relay. After repairs, go to step 35).

21) Repair switch side voltage supply circuit of A/C compressor clutch relay. After repairs, go to step 35).

22) Check control circuit (Dark Green/White wire) of A/C compressor clutch relay for open, or short to ground. If problem was found, repair as necessary. After repairs, go to step 35). If problem was not found, go to step 28).

23) Check A/C high pressure sensor connector for poor connections. If problem was found, repair as necessary. After repairs, go to step 35). If problem was not found, go to step 29).

24) Check A/C compressor clutch relay connector for poor connections. If problem was found, repair as necessary. After repairs, go to step 35). If problem was not found, go to step 30).

25) Check A/C compressor clutch coil connector for poor connections. If problem was found, repair as necessary. After repairs, go to step 35). If problem was not found, go to step 31).

26) Check HVAC control assembly connector for poor connections. If problem was found, repair as necessary. After repairs, go to step 35). If problem was not found, go to step 32).

27) Check BCM connectors for poor connections. If problem was found, repair as necessary. After repairs, go to step 35). If problem was not found, go to step 33).

28) Check PCM connectors for poor connections. If problem was found, repair as necessary. After repairs, go to step 35). If problem was not found, go to step 34).

29) Replace A/C high pressure switch. After repairs, go to step 35).

30) Replace A/C compressor clutch relay. After repairs, go to step 35).

31) Replace A/C compressor clutch coil. See appropriate COMPRESSOR SERVICING article in GENERAL SERVICING. After repairs, go to step 35).

32) Replace HVAC control assembly. See REMOVAL & INSTALLATION in appropriate MANUAL A/C-HEATER SYSTEMS article. After repairs, go to step 35).

33) Replace BCM. See appropriate BODY CONTROL MODULES article in ACCESSORIES & EQUIPMENT. After repairs, go to step 35).

34) Replace PCM. See appropriate REMOVAL, OVERHAUL & INSTALLATION article in ENGINE PERFORMANCE. After repairs, go to next step.

35) Operate system to verify repair.

Compressor Clutch Does Not Disengage

1) If diagnostic system check has not been performed, see DIAGNOSTIC SYSTEM CHECK. If diagnostic system check has been performed, go to next step.

2) Start engine. Turn mode switch to OFF position. Place A/C request switch in OFF position. If A/C compressor operates, go to next step. If A/C compressor does not operate, problem is intermittent.

3) Using scan tool, observe A/C REQUEST parameter in POWERTRAIN DATA LIST 2. If scan tool indicates A/C REQUEST parameter is OFF, go to next step. If scan tool does not indicate A/C REQUEST parameter is OFF, go to step 6).

4) Using scan tool, observe A/C RELAY COMMANDED parameter in BODY CONTROL MODULE DATA LIST 2. If scan tool indicates A/C RELAY COMMANDED parameter is OFF, go to next step. If scan tool does not indicate A/C RELAY COMMAND parameter is OFF, go to step 14)

5) Check control circuit (Dark Green/White wire) of A/C compressor clutch relay for short to ground. If problem was found, repair as necessary. After repairs, go to step 20). If problem was not found, go to step 7).

6) Start engine. Place A/C switch in OFF position. Measure voltage between A/C request circuit (Light Green wire) at BCM and ground. If battery voltage is present, go to step 9). If battery voltage is not present, go to step 13).

7) Remove A/C compressor clutch relay. If A/C compressor

clutch turns off, go to step 10). If A/C compressor clutch does not turn off, go to next step.

8) Check A/C compressor clutch voltage supply circuit (Dark Green wire) for short to voltage. If problem was found, repair as necessary. After repairs, go to step 20). If problem was not found, go to step 11).

9) Check A/C request signal circuit (Light Green wire) for short to voltage. If problem was found, repair as necessary. After repairs, go to step 20). If problem was not found, go to step 12).

10) Check A/C compressor clutch relay connector for poor connections. If problem was found, repair as necessary. After repairs, go to step 20). If problem was not found, go to step 15).

11) Check A/C compressor clutch connector for poor connections. If problem was found, repair as necessary. After repairs, go to step 20). If problem was not found, go to step 16).

12) Check HVAC control assembly connector for poor connections. If problem was found, repair as necessary. After repairs, go to step 20). If problem was not found, go to step 17).

13) Check BCM connectors for poor connections. If problem was found, repair as necessary. After repairs, go to step 20). If problem was not found, go to step 18).

14) Check PCM connectors for poor connections. If problem was found, repair as necessary. After repairs, go to step 20). If problem was not found, go to step 19).

15) Replace A/C compressor clutch relay. After repairs, go to step 20).

16) Replace A/C compressor clutch. See appropriate COMPRESSOR SERVICING article in GENERAL SERVICING. After repairs, go to step 20).

17) Replace HVAC control assembly. See REMOVAL & INSTALLATION in appropriate MANUAL A/C-HEATER SYSTEMS article. After repairs, go to step 20).

18) Replace BCM. See appropriate BODY CONTROL MODULES article in ACCESSORIES & EQUIPMENT. After repairs, go to step 20).

19) Replace PCM. See appropriate REMOVAL, OVERHAUL & INSTALLATION article in ENGINE PERFORMANCE. After repairs, go to next step.

20) Operate system to verify repair.

Diagnostic Aids

If DTCs P0530, U1016 or U1064 are set, diagnose them before proceeding. See appropriate SELF-DIAGNOSTICS article in ENGINE PERFORMANCE. If problem is insufficient cooling, check cooling fans for proper operation. See ELECTRIC COOLING FANS - ALL MODELS article. If cooling fans operate correctly, diagnose manual A/C-heater system. See appropriate MANUAL A/C-HEATER SYSTEMS article.

An A/C refrigerant pressure less than 43 psi (3.0 kg/cm²), or greater than 428 psi (30.1 kg/cm²), will cause PCM to disable A/C compressor clutch. With engine running and A/C on, use scan tool to monitor A/C high-side system pressure for 2 minutes. If pressure goes out of range, diagnose manual A/C-heater system. See appropriate MANUAL A/C-HEATER SYSTEMS article.

3.0L: CATERA

NOTE: For circuit, wire color and terminal identification, see WIRING DIAGRAMS. Also see WIRING DIAGRAMS in appropriate MANUAL or AUTOMATIC A/C HEATER SYSTEMS article.

NOTE: Catera is equipped with an anti-theft system. ECM must be programmed when replaced. See appropriate ANTI-THEFT SYSTEMS article in ACCESSORIES & EQUIPMENT or COMPUTER RELEARN PROCEDURES article in GENERAL INFORMATION in ENGINE

PERFORMANCE.

Description (A/C Request Circuit)

For proper A/C system operation, the A/C request circuit monitors selected A/C mode, A/C system pressure and throttle position. When A/C mode is selected with A/C system pressure and throttle angle at a predetermined value, Engine Control Module (ECM) energizes A/C clutch relay through A/C clutch relay control circuit. The ECM de-energizes A/C clutch relay during wide open throttle, when engine coolant temperature or A/C system pressure exceeds a predetermined threshold, or when a non-A/C mode is selected. If system does not operate as specified, see DIAGNOSTIC SYSTEM CHECK.

Description (A/C Load Signal Circuit)

The ECM receives a signal from the A/C load signal circuit. A normally open pressure switch connected to battery voltage monitors A/C system operating pressures. If pressures reach approximately 175 psi (12.2 kg/cm²) the switch will close, sending a signal to the ECM. The ECM will raise idle speed around 50 RPM to compensate for the additional load. If system does not operate as specified, see DIAGNOSTIC SYSTEM CHECK.

Description (A/C Compressor Control Circuit)

The ECM controls the ground side of the A/C clutch relay to energize the A/C compressor clutch. When component is commanded on by the ECM, voltage on the control circuit should be at or near zero volts. When component is commanded off by the ECM, voltage on the control circuit should be at or near battery voltage. If system does not operate as specified, see DIAGNOSTIC SYSTEM CHECK.

Diagnostic System Check

- 1) Install scan tool. If scan tool powers up, go to next step. If scan tool does not power up, see SCAN TOOL DOES NOT POWER UP in appropriate BODY CONTROL MODULES article.
- 2) Turn ignition on, engine off. Try to establish scan tool communication with Instrument Panel Cluster (IPC), Body Control Module (BCM) and Powertrain Control Module (PCM). If communication with all modules is established, go to next step. If communication with all modules is not established, see SCAN TOOL DOES NOT COMMUNICATE WITH CLASS 2 DEVICE in appropriate BODY CONTROL MODULES article.
- 3) Select display DTC function for each module. Record all displayed DTCs, status of displayed DTCs and which module set DTC. If DTCs are displayed, go to next step. If no DTCs are displayed, see COMPRESSOR CLUTCH DOES NOT ENGAGE or COMPRESSOR CLUTCH DOES NOT DISENGAGE.
- 4) If scan tool displays any DTCs beginning with "B", see appropriate SELF-DIAGNOSTICS article in BODY CONTROL MODULES. If scan tool displays DTCs beginning with "P", see appropriate SELF-DIAGNOSTICS article in ENGINE PERFORMANCE. If scan tool displays DTCs beginning with "U", see SCAN TOOL DOES NOT COMMUNICATE WITH CLASS 2 DEVICE in appropriate BODY CONTROL MODULES article.

Compressor Clutch Does Not Engage

- 1) If diagnostic system check has not been performed, see DIAGNOSTIC SYSTEM CHECK. If diagnostic system check has been performed, go to next step.
- 2) Ensure outside air temperature is greater than 38°F (3°C). Start engine. Turn blower motor switch to maximum speed position. Place A/C switch in ON position. Place air temperature control switch in coldest position. If A/C compressor operates, problem is intermittent. If A/C compressor does not operate, go to next step.
- 3) Park vehicle inside or in shade. Open windows in order to ventilate interior of vehicle. If A/C system was operating, then allow

A/C system to equalize for about 2 minutes. Turn ignition switch to OFF position. Install Refrigerant Station (J 43600 ACR 2000). Record outside air temperature at vehicle. Record readings of low and high side static pressures. Compare pressure values with specifications for ambient air temperature. See PRESSURE-TEMPERATURE RELATIONSHIP article in GENERAL SERVICING. If pressure values are within specification for ambient air temperature and within 15 psi (1.1 kg/cm²) of each other, go to next step. If pressure values are not within specification for ambient air temperature or within 15 psi (1.1 kg/cm²) of each other, see LEAK TESTING article in GENERAL SERVICING.

4) Using scan tool, command A/C compressor clutch relay on and off. If A/C compressor clutch relay turns on and off with each command, go to next step. If A/C compressor clutch relay does not turn on and off with each command, go to step 6).

5) Turn ignition switch to OFF position. Disconnect A/C compressor clutch relay. Using test light connected to ground, probe switch side voltage supply circuit (Red wire) of A/C compressor clutch relay. If test light is on, go to step 7). If test light is off, go to step 17).

6) Turn ignition switch to OFF position. Disconnect A/C compressor clutch relay. Turn ignition to ON position, with engine off. Using test light connected to ground, probe coil side voltage supply circuit (Brown wire) of A/C compressor clutch relay. If test light is on, go to step 9). If test light is off, go to step 16).

7) Connect fused jumper (10 amp) between switch side voltage circuit (Red wire) of A/C compressor clutch relay and A/C compressor clutch supply voltage circuit (Green wire) of A/C compressor clutch. Turn ignition to ON position, with engine off. If A/C compressor clutch engages, go to step 18). If A/C compressor clutch does not engage, go to next step.

8) Check A/C compressor clutch supply voltage circuit (Green wire) at A/C compressor clutch for short to ground, high resistance, or open. If problem was found, repair as necessary. After repairs, go to step 26). If problem was not found, go to step 13).

9) Connect test light between control circuit (Brown/Purple wire) of A/C compressor clutch relay and coil side voltage supply circuit (Brown wire) of A/C compressor clutch relay. Using scan tool, command A/C compressor clutch relay on and off. If test light turns on and off with each command, go to step 18). If test light does not turn on and off with each command, go to next step.

10) If test light remains on with each command, go to next step. If test light does not remain on with each command, go to step 12).

11) Check control circuit (Brown/Purple wire) and A/C cut out input circuit (Yellow/Blue wire) of A/C compressor clutch relay for short to ground. If problem was found, repair as necessary. After repairs, go to step 26). If problem was not found, go to step 19).

12) Check control circuit (Brown/Purple wire) of A/C compressor clutch relay for open. If problem was found, repair as necessary. After repairs, go to step 26). If problem was not found, go to step 19).

13) Check ground circuit (Brown/Black wire) between A/C compressor clutch and secondary cooling fan temperature switch for high resistance or open. If problem was found, repair as necessary. After repairs, go to step 26). If problem was not found, go to next step.

14) Check ground circuit (Black wire) of secondary cooling fan temperature switch for high resistance or open. If problem was found, repair as necessary. After repairs, go to step 26). If problem was not found, go to next step.

15) Ensure engine coolant temperature is less than 248 °F (120 °C). Measure resistance between switch side, secondary cooling fan temperature switch terminals. If resistance is near zero, go to step

20). If resistance is not near zero, go to step 21).

16) Repair coil side voltage supply circuit (Brown wire) of A/C compressor clutch relay. After repairs, go to step 26).

17) Repair switch side voltage supply circuit (Red wire) of A/C compressor clutch relay. After repairs, go to step 26).

18) Check A/C compressor clutch relay connector for poor connections. If problem was found, repair as necessary. After repairs, go to step 26). If problem was not found, go to step 22).

19) Check ECM connectors for poor connections. If problem was found, repair as necessary. After repairs, go to step 26). If problem was not found, go to step 25).

20) Check A/C compressor clutch connector for poor connections. If problem was found, repair as necessary. After repairs, go to step 26). If problem was not found, go to step 24).

21) Check secondary cooling fan temperature switch connector for poor connections. If problem was found, repair as necessary. After repairs, go to step 26). If problem was not found, go to step 23).

22) Replace A/C compressor clutch relay. After repairs, go to step 26).

23) Replace secondary cooling fan temperature switch. After repairs, go to step 26).

24) Replace A/C compressor clutch. See appropriate COMPRESSOR SERVICING article in GENERAL SERVICING. After repairs, go to step 26).

25) Replace ECM. See appropriate REMOVAL, OVERHAUL & INSTALLATION article in ENGINE PERFORMANCE. After repairs, go to next step.

26) Operate system to verify repair.

Compressor Clutch Does Not Disengage

1) If diagnostic system check has not been performed, see DIAGNOSTIC SYSTEM CHECK. If diagnostic system check has been performed, go to next step.

2) Start engine. Place A/C request switch in OFF position. If A/C compressor operates, go to next step. If A/C compressor does not operate, problem is intermittent.

3) Remove A/C compressor clutch relay. If A/C compressor clutch turns off, go to next step. If A/C compressor clutch does not turn off, go to step 5).

4) Measure resistance between switch side A/C compressor clutch relay terminals. If resistance is infinite, go to step 6). If resistance is not infinite, go to step 7).

5) Check A/C compressor clutch supply voltage circuit (Green wire) for short to voltage. If problem was found, repair as necessary. After repairs, go to step 12). If problem was not found, go to step 10).

6) Check A/C clutch relay control circuit (Brown/Purple wire) to ECM and A/C cut out input circuit (Yellow/Blue wire) to A/C-heater control for short to ground. If problem was found, repair as necessary. After repairs, go to step 12). If problem was not found, go to step 8).

7) Check A/C compressor clutch relay connector for poor connections. If problem was found, repair as necessary. After repairs, go to step 12). If problem was not found, go to step 9).

8) Check ECM connectors for poor connections. If problem was found, repair as necessary. After repairs, go to step 12). If problem was not found, go to step 11).

9) Replace A/C compressor clutch relay. After repairs, go to step 12).

10) Replace the A/C compressor clutch. See appropriate COMPRESSOR SERVICING article in GENERAL SERVICING. After repairs, go to step 12).

11) Replace ECM. See appropriate REMOVAL, OVERHAUL & INSTALLATION article in ENGINE PERFORMANCE. After repairs, go to next

step.

12) Operate system to verify repair.

Diagnostic Aids

An intermittent condition may be caused by corrosion, misrouted wiring harness, rubbed through wire insulation, or a wire broken inside insulation. Perform visual inspection and check for continuity along suspect circuits. Repair as necessary.

3.1L, 3.5L & 3.8L: CENTURY, INTRIGUE & REGAL

NOTE: For circuit, wire color and terminal identification, see WIRING DIAGRAMS. Also see WIRING DIAGRAMS in appropriate MANUAL or AUTOMATIC A/C HEATER SYSTEMS article.

Description

When A/C is selected through A/C control panel, a 12-volt signal is supplied to A/C request input terminal of PCM. A/C clutch relay is controlled through PCM which also monitors A/C refrigerant pressure. If A/C refrigerant pressure, and engine operating conditions are within a specific calibrated acceptable range, the PCM will enable A/C clutch relay. This is accomplished by providing a ground path for A/C clutch relay coil with PCM. When A/C clutch relay is enabled, battery voltage is supplied to compressor clutch coil.

The PCM will enable A/C compressor clutch whenever engine is running and A/C has been requested, unless:

- * Throttle angle is greater than 90 percent.
- * A/C head pressure is greater than 414 psi (29.1 kg/cm²) with A/C refrigerant pressure sensor reading greater than 4.27 volts.
- * A/C head pressure is less than 35 psi (2.5 kg/cm²) with A/C refrigerant pressure sensor reading greater than .40 volts.
- * Ignition voltage is less than 10.5 volts.
- * Engine speed is greater than 4500 RPM for 5 seconds or at 5400 RPM for any amount of time.
- * Engine coolant temperature is greater than 257°F (125°C).
- * Intake air temperature is less than 41°F (5°C).

Diagnostic System Check

1) Install scan tool. If scan tool powers up, go to next step. If scan tool does not power up, see SCAN TOOL DOES NOT POWER UP in appropriate BODY CONTROL MODULES article.

2) Turn ignition on, engine off. Try to establish scan tool communication with HVAC control module, Body Control Module (BCM) and Powertrain Control Module (PCM). If communication with all modules is established, go to next step. If communication with all modules is not established, see SCAN TOOL DOES NOT COMMUNICATE WITH CLASS 2 DEVICE in appropriate BODY CONTROL MODULES article.

3) Select display DTC function for each module. Record all displayed DTCs, status of displayed DTCs and which module set DTC. If DTCs are displayed, go to next step. If no DTCs are displayed, see COMPRESSOR CLUTCH DOES NOT ENGAGE (AUTOMATIC A/C), COMPRESSOR CLUTCH DOES NOT ENGAGE (MANUAL A/C), COMPRESSOR CLUTCH DOES NOT DISENGAGE (AUTOMATIC A/C) or COMPRESSOR CLUTCH DOES NOT DISENGAGE (MANUAL A/C).

4) If scan tool displays any DTCs beginning with "B", see appropriate SELF-DIAGNOSTICS article in BODY CONTROL MODULES. If scan tool displays DTCs beginning with "P", see appropriate SELF-DIAGNOSTICS article in ENGINE PERFORMANCE. If scan tool displays DTCs beginning with "U", see SCAN TOOL DOES NOT COMMUNICATE WITH CLASS 2 DEVICE in appropriate BODY CONTROL MODULES article.

Compressor Clutch Does Not Engage (Automatic A/C)

1) If diagnostic system check has not been performed, see DIAGNOSTIC SYSTEM CHECK. If diagnostic system check has been performed, go to next step.

2) Ensure outside air temperature is greater than 38°F (3°C). Start engine. Turn blower motor switch to maximum speed position. Place A/C switch in ON position. Place air temperature control switch in coldest position. If A/C compressor operates, problem is intermittent. If A/C compressor does not operate, go to next step.

3) Park vehicle inside or in shade. Open windows in order to ventilate interior of vehicle. If A/C system was operating, then allow A/C system to equalize for about 2 minutes. Turn ignition switch to OFF position. Install Refrigerant Station (J 43600 ACR 2000). Record outside air temperature at vehicle. Record readings of low and high side static pressures. Compare pressure values with specifications for ambient air temperature. See PRESSURE-TEMPERATURE RELATIONSHIP article in GENERAL SERVICING. If pressure values are within specification for ambient air temperature and within 15 psi (1.1 kg/cm²) of each other, go to next step. If pressure values are not within specification for ambient air temperature or within 15 psi (1.1 kg/cm²) of each other, see LEAK TESTING article in GENERAL SERVICING.

4) Turn ignition switch to ON position, with engine off. Using scan tool, observe A/C HIGH SIDE PRESSURE SENSOR parameter in POWERTRAIN data list. Compare A/C high side pressure on scan tool to high side pressure value on refrigerant station. If high side pressure values are within 15 psi (1.1 kg/cm²) of each other, go to next step. If high side pressure values are not within 15 psi (1.1 kg/cm²) of each other, go to step 15).

5) HVAC control module is inoperative when module does not respond to any operator control requests. If HVAC control module is inoperative, go to step 14). If HVAC control module is not inoperative, go to next step.

6) Start engine. Using scan tool, observe A/C REQUEST parameter in POWERTRAIN data list. Turn air temperature switch to coldest position. Place A/C REQUEST switch in ON position. If scan tool indicates A/C REQUEST parameter is YES, go to next step. If scan tool does not indicate A/C request is YES, go to step 26).

7) Using scan tool, observe A/C RELAY COMMAND status in POWERTRAIN Data List. If scan tool indicates A/C RELAY COMMAND status is ON, go to next step. If scan tool does not indicate A/C RELAY COMMAND status is ON, go to step 27).

8) Using scan tool, command A/C compressor clutch relay on and off. If A/C compressor clutch relay turns on and off with each command, go to step 12). If A/C compressor clutch relay does not turn on and off with each command, go to next step.

9) Turn ignition switch to OFF position. Disconnect A/C compressor clutch relay. Turn ignition to ON position, with engine off. Using test light connected to ground, probe coil side voltage supply circuit of A/C compressor clutch relay. If test light is on, go to next step. If test light is off, go to step 22).

10) Connect test light between control circuit (Dark Green/White wire) of A/C compressor clutch relay and the coil side voltage supply circuit of A/C compressor clutch relay. Using scan tool, command A/C compressor clutch relay on and off. If test light turns on and off with each command, go to step 24). If test light does not turn on and off with each command, go to next step.

11) If test light remains on with each command, go to step 18). If test light does not remain on with each command, go to step 17).

12) Turn ignition switch to off position. Disconnect A/C compressor clutch relay. Using test light connected to ground, probe switch side voltage supply circuit of A/C compressor clutch relay. If

test light is on, go to next step. If test light is not on, go to step 21).

13) Connect fused jumper (10 amp) between switch side voltage circuit of A/C compressor clutch relay and A/C compressor clutch supply voltage circuit (Dark Green wire) of A/C compressor clutch. Turn ignition switch to ON position, with engine off. If A/C compressor clutch engages, go to step 24). If A/C compressor clutch does not engage, go to step 19).

14) Check ignition voltage circuit (Brown wire) of HVAC control assembly for short to ground, high resistance, or open. If problem was found, repair as necessary. After repairs, go to step 33). If problem was not found, go to step 16).

15) Check ground circuit (Black wire) of A/C pressure sensor for open. If problem was found, repair as necessary. After repairs, go to step 33). If problem was not found, go to step 23).

16) Check ground circuit (Black wire) of HVAC control module for open. If problem was found, repair as necessary. After repairs, go to step 33). If problem was not found, go to step 26).

17) Check control circuit (Dark Green/White wire) of A/C compressor clutch relay for open. If problem was found, repair as necessary. After repairs, go to step 33). If problem was not found, go to step 27).

18) Check control circuit (Dark Green/White wire) of A/C compressor clutch relay for short to ground. If problem was found, repair as necessary. After repairs, go to step 33). If problem was not found, go to step 27).

19) Check A/C compressor clutch supply voltage circuit (Dark Green wire) at A/C compressor clutch for short to ground, high resistance, or open. If problem was found, repair as necessary. After repairs, go to step 33). If problem was not found, go to next step.

20) Check ground circuit (Black wire) of A/C compressor clutch for high resistance or open. If problem was found, repair as necessary. After repairs, go to step 33). If problem was not found, go to step 25).

21) Repair switch side voltage supply circuit of A/C compressor clutch relay. After repairs, go to step 33).

22) Repair coil side voltage supply circuit of A/C compressor clutch relay. After repairs, go to step 33).

23) Check A/C high pressure sensor connector for poor connections. If problem was found, repair as necessary. After repairs, go to step 33). If problem was not found, go to step 28).

24) Check A/C compressor clutch relay connector for poor connections. If problem was found, repair as necessary. After repairs, go to step 33). If problem was not found, go to step 29).

25) Check A/C compressor clutch connector for poor connections. If problem was found, repair as necessary. After repairs, go to step 33). If problem was not found, go to step 30).

26) Check HVAC control module connector for poor connections. If problem was found, repair as necessary. After repairs, go to step 33). If problem was not found, go to step 31).

27) Check PCM connectors for poor connections. If problem was found, repair as necessary. After repairs, go to step 33). If problem was not found, go to step 32).

28) Replace A/C high pressure switch. After repairs, go to step 33).

29) Replace A/C compressor clutch relay. After repairs, go to step 33).

30) Replace the A/C compressor clutch coil. See appropriate COMPRESSOR SERVICING article in GENERAL SERVICING. After repairs, go to step 33).

31) Replace HVAC control assembly. See REMOVAL & INSTALLATION in appropriate AUTOMATIC A/C-HEATER SYSTEMS article. After repairs, go to step 33).

32) Replace PCM. See appropriate REMOVAL, OVERHAUL & INSTALLATION article in ENGINE PERFORMANCE. After repairs, go to next step.

33) Operate system to verify repair.

Compressor Clutch Does Not Engage (Manual A/C)

1) If diagnostic system check has not been performed, see DIAGNOSTIC SYSTEM CHECK. If diagnostic system check has been performed, go to next step.

2) Ensure outside air temperature is greater than 38°F (3°C). Start engine. Turn blower motor switch to maximum speed position. Place A/C switch in ON position. Place air temperature control switch in coldest position. If A/C compressor operates, problem is intermittent. If A/C compressor does not operate, go to next step.

3) Park vehicle inside or in shade. Open windows in order to ventilate interior of vehicle. If A/C system was operating, then allow A/C system to equalize for about 2 minutes. Turn ignition switch to OFF position. Install Refrigerant Station (J 43600 ACR 2000). Record outside air temperature at vehicle. Record readings of low and high side static pressures. Compare pressure values with specifications for ambient air temperature. See PRESSURE-TEMPERATURE RELATIONSHIP article in GENERAL SERVICING. If pressure values are within specification for ambient air temperature and within 15 psi (1.1 kg/cm²) of each other, go to next step. If pressure values are not within specification for ambient air temperature or within 15 psi (1.1 kg/cm²) of each other, see LEAK TESTING article in GENERAL SERVICING.

4) Turn ignition switch to ON position, with engine off. Using scan tool, observe A/C HIGH SIDE PRESSURE SENSOR parameter in POWERTRAIN data list. Compare A/C high side pressure on scan tool to high side pressure value on refrigerant station. If high side pressure values are within 15 psi (1.1 kg/cm²) of each other, go to next step. If high side pressure values are not within 15 psi (1.1 kg/cm²) of each other, go to step 17).

5) If HVAC control module is inoperative, go to step 16). If HVAC control module is not inoperative, go to next step.

6) Start engine. Using scan tool, observe A/C REQUEST parameter in POWERTRAIN data list. Turn air temperature switch to coldest position. Turn blower motor to ON position. Place A/C request switch in ON position. If scan tool indicates A/C REQUEST parameter is ON, go to step 10). If scan tool does not indicate A/C REQUEST parameter is ON, go to next step.

7) If A/C request indicator illuminates, go to step 9). If A/C request indicator does not illuminate, go to next step.

8) Ensure blower motor switch is ON position. Turn ignition switch to ON position. Check blower motor off circuit (Dark Green wire) at HVAC control assembly for short to voltage. If problem was found, repair as necessary. After repairs, go to step 35). If problem was not found, go to step 28).

9) Turn ignition to off position. Check A/C request signal circuit (Dark Green/White wire) for short to ground, high resistance, or open. If problem was found, repair as necessary. After repairs, go to step 35). If problem was not found, go to step 29).

10) Using scan tool, command A/C compressor clutch relay on and off. If A/C compressor clutch relay turns on and off with each command, go to step 14). If A/C compressor clutch relay does not turn on and off with each command, go to next step.

11) Turn ignition switch to OFF position. Disconnect A/C compressor clutch relay. Turn ignition switch to ON position, with engine off. Using test light connected to ground, probe coil side voltage supply circuit of A/C compressor clutch relay. If test light is on, go to next step. If test light is off, go to step 23).

12) Connect test light between control circuit (Dark Green/White wire) of A/C compressor clutch relay and coil side voltage

supply circuit of A/C compressor clutch relay. Using scan tool, command A/C compressor clutch relay on and off. If test light turns on and off with each command, go to step 24). If test light does not turn on and off with each command, go to next step.

13) If test light remains on with each command, go to step 20). If test light does not remain on with each command, go to step 19).

14) Turn ignition switch to off position. Disconnect A/C compressor clutch relay. Using test light connected to ground, probe switch side voltage supply circuit of A/C compressor clutch relay. If test light is on, go to next step. If test light is off, go to step 24).

15) Connect fused jumper (10 amp) between switch side voltage circuit of A/C compressor clutch relay and A/C compressor clutch supply voltage circuit (Dark Green wire) of A/C compressor clutch. Turn ignition switch to ON position, with engine off. If A/C compressor clutch engages, go to step 26). If A/C compressor clutch does not engage, go to step 21).

16) Check ignition voltage circuit (Brown wire) of HVAC control module for short to ground, high resistance, or open. If problem was found, repair as necessary. After repairs, go to step 35). If problem was not found, go to step 18).

17) Check ground circuit (Black wire) of A/C pressure sensor for open. If problem was found, repair as necessary. After repairs, go to step 35). If problem was not found, go to step 25).

18) Check ground circuit (Black wire) of HVAC control module for open. If problem was found, repair as necessary. After repairs, go to step 35). If problem was not found, go to step 28).

19) Check control circuit (Dark Green/White wire) of A/C compressor clutch relay for open. If problem was found, repair as necessary. After repairs, go to step 35). If problem was not found, go to step 29).

20) Check control circuit (Dark Green/White wire) of A/C compressor clutch relay for short to ground. If problem was found, repair as necessary. After repairs, go to step 35). If problem was not found, go to step 29).

21) Check A/C compressor clutch supply voltage circuit (Dark Green wire) at A/C compressor clutch for short to ground, high resistance, or open. If problem was found, repair as necessary. After repairs, go to step 35). If problem was not found, go to next step.

22) Check ground circuit (Black wire) of A/C compressor clutch for high resistance or open. If problem was found, repair as necessary. After repairs, go to step 35). If problem was not found, go to step 27).

23) Repair switch side voltage supply circuit of A/C compressor clutch relay. After repairs, go to step 35).

24) Repair coil side voltage supply circuit of A/C compressor clutch relay. After repairs, go to step 35).

25) Check A/C high pressure sensor connector for poor connections. If problem was found, repair as necessary. After repairs, go to step 35). If problem was not found, go to step 30).

26) Check A/C compressor clutch relay connector for poor connections. If problem was found, repair as necessary. After repairs, go to step 35). If problem was not found, go to step 31).

27) Check A/C compressor clutch connector for poor connections. If problem was found, repair as necessary. After repairs, go to step 35). If problem was not found, go to step 32).

28) Check HVAC control module connector for poor connections. If problem was found, repair as necessary. After repairs, go to step 35). If problem was not found, go to step 33).

29) Check PCM connectors for poor connections. If problem was found, repair as necessary. After repairs, go to step 35). If problem was not found, go to step 34).

- 30) Replace A/C high pressure switch. After repairs, go to step 35).
- 31) Replace A/C compressor clutch relay. After repairs, go to step 35).
- 32) Replace the A/C compressor clutch coil. See appropriate COMPRESSOR SERVICING article in GENERAL SERVICING. After repairs, go to step 35).
- 33) Replace HVAC control module. See REMOVAL & INSTALLATION in appropriate MANUAL A/C-HEATER SYSTEMS article. After repairs, go to step 35).
- 34) Replace PCM. See appropriate REMOVAL, OVERHAUL & INSTALLATION article in ENGINE PERFORMANCE. After repairs, go to next step.
- 35) Operate system to verify repair.

Compressor Clutch Does Not Disengage (Automatic A/C)

- 1) If diagnostic system check has not been performed, see DIAGNOSTIC SYSTEM CHECK. If diagnostic system check has been performed, go to next step.
- 2) Start engine. Turn blower motor switch to OFF position. Place A/C request switch in OFF position. If A/C compressor operates, go to next step. If A/C compressor does not operate, problem is intermittent.
- 3) Using scan tool, observe A/C RELAY COMMAND STATUS in POWERTRAIN data list. If scan tool indicates A/C RELAY COMMAND STATUS is ON, go to next step. If scan tool does not indicate A/C RELAY COMMAND STATUS is ON, go to step 5).
- 4) Using scan tool, observe A/C REQUEST parameter in the POWERTRAIN data list. If scan tool indicates A/C REQUEST parameter is YES, go to step 10). If scan tool does not indicate A/C REQUEST parameter is YES, go to step 11).
- 5) Remove A/C compressor clutch relay. If A/C compressor clutch turns off, go to next step. If A/C compressor clutch does not turn off, go to step 8).
- 6) Measure resistance between switch side A/C compressor clutch relay terminals. If resistance is infinite, go to next step. If resistance is not infinite, go to step 9).
- 7) Check A/C clutch relay control circuit (Dark Green/White wire) for short to ground. If problem was found, repair as necessary. After repairs, go to step 16). If problem was not found, go to step 11).
- 8) Check A/C compressor clutch supply voltage circuit (Dark Green wire) for short to voltage. If problem was found, repair as necessary. After repairs, go to step 16). If problem was not found, go to step 13).
- 9) Check A/C compressor clutch relay connector for poor connections. If problem was found, repair as necessary. After repairs, go to step 16). If problem was not found, go to step 12).
- 10) Check HVAC control module connector for poor connections. If problem was found, repair as necessary. After repairs, go to step 16). If problem was not found, go to step 14).
- 11) Check PCM connectors for poor connections. If problem was found, repair as necessary. After repairs, go to step 16). If problem was not found, go to step 15).
- 12) Replace A/C compressor clutch relay. After repairs, go to step 16).
- 13) Replace A/C compressor clutch. See appropriate COMPRESSOR SERVICING article in GENERAL SERVICING. After repairs, go to step 16).
- 14) Replace HVAC control module. See REMOVAL & INSTALLATION in appropriate AUTOMATIC A/C-HEATER SYSTEMS article. After repairs, go to step 16).
- 15) Replace PCM. See appropriate REMOVAL, OVERHAUL & INSTALLATION article in ENGINE PERFORMANCE. After repairs, go to next

step.

16) Operate system to verify repair.

Compressor Clutch Does Not Disengage (Manual A/C)

1) If diagnostic system check has not been performed, see DIAGNOSTIC SYSTEM CHECK. If diagnostic system check has been performed, go to next step.

2) Start engine. Turn blower motor switch to OFF position. Place A/C request switch in OFF position. If A/C compressor operates, go to next step. If A/C compressor does not operate, problem is intermittent.

3) Using scan tool, observe A/C REQUEST parameter in POWERTRAIN data list. If scan tool indicates A/C REQUEST parameter is ON, go to next step. If scan tool does not indicate A/C REQUEST parameter is ON, go to step 6).

4) Check A/C request signal circuit (Dark Green/White wire) for short to ground. If problem was found, repair as necessary. After repairs, go to step 17). If problem was not found, go to next step.

5) Turn ignition switch to OFF position. Back out terminal for A/C request circuit (Dark Green/White wire) at HVAC control head. Start engine. Using scan tool, observe A/C REQUEST parameter. If scan tool indicates A/C REQUEST parameter is ON, go to step 12). If scan tool does not indicate A/C REQUEST parameter is ON, go to step 11).

6) Remove A/C compressor clutch relay. If A/C compressor clutch turns off, go to next step. If A/C compressor clutch does not turn off, go to step 9).

7) Measure resistance between switch side A/C compressor clutch relay terminals. If resistance is infinite, go to next step. If resistance is not infinite, go to step 10).

8) Check A/C clutch relay control circuit (Dark Green/White wire) for short to ground. If problem was found, repair as necessary. After repairs, go to step 17). If problem was not found, go to step 12).

9) Check A/C compressor clutch supply voltage circuit (Dark Green wire) for short to voltage. If problem was found, repair as necessary. After repairs, go to step 17). If problem was not found, go to step 14).

10) Check A/C compressor clutch relay connector for poor connections. If problem was found, repair as necessary. After repairs, go to step 17). If problem was not found, go to step 13).

11) Check HVAC control module connector for poor connections. If problem was found, repair as necessary. After repairs, go to step 17). If problem was not found, go to step 15).

12) Check PCM connectors for poor connections. If problem was found, repair as necessary. After repairs, go to step 17). If problem was not found, go to step 16).

13) Replace A/C compressor clutch relay. After repairs, go to step 17).

14) Replace A/C compressor clutch. See appropriate COMPRESSOR SERVICING article in GENERAL SERVICING. After repairs, go to step 17).

15) Replace HVAC control module. See REMOVAL & INSTALLATION in appropriate MANUAL A/C-HEATER SYSTEMS article. After repairs, go to step 17).

16) Replace PCM. See appropriate REMOVAL, OVERHAUL & INSTALLATION article in ENGINE PERFORMANCE. After repairs, go to next step.

17) Operate system to verify repair.

Diagnostic Aids

An intermittent condition may be caused by corrosion, misrouted wiring harness, rubbed through wire insulation or a wire broken inside insulation. Perform visual inspection and check for continuity along suspect circuits. Repair as necessary.

3.1L & 3.8L: GRAND PRIX

NOTE: For circuit, wire color and terminal identification, see WIRING DIAGRAMS.

Also see WIRING DIAGRAMS in appropriate MANUAL or AUTOMATIC A/C HEATER SYSTEMS article.

Description

Compressor for air conditioning system is belt-driven by engine through A/C compressor clutch. Clutch allows compressor to engage for A/C and defroster operation, disengage when air conditioning is not requested and disengage when engine load must be reduced. Battery voltage is supplied to powertrain control module (PCM) when heater and A/C control mode selector knob is in MAX A/C, NORM A/C, BI-LEVEL, DEFOG or DEFROST modes. Voltage signal tells PCM that A/C compressor operation is requested. Under normal operating conditions, PCM supplies a ground to relay coil of A/C compressor control. Relay energizes. Voltage is supplied to A/C compressor clutch through relay center fuse. A/C compressor clutch engages. Compressor runs. If PCM determines engine load should be reduced, such as during full throttle conditions, PCM de-energizes A/C compressor control relay in order to disengage compressor clutch. De-energization occurs even though voltage signal from heater and A/C control is still present. Diode of A/C compressor clutch connects across terminals of A/C compressor clutch. Diode provides a path for current which results from voltage spikes. Voltage spikes generate from collapsing magnetic field of A/C compressor clutch coil. Voltage spikes occur every time coil de-energizes.

Diagnostic System Check

- 1) Install scan tool. If scan tool powers up, go to next step. If scan tool does not power up, see SCAN TOOL DOES NOT POWER UP in appropriate BODY CONTROL MODULES article.
- 2) Turn ignition on, engine off. Try to establish scan tool communication with Powertrain Control Module (PCM). If communication with PCM is established, go to next step. If communication with PCM is not established, see SCAN TOOL DOES NOT COMMUNICATE WITH CLASS 2 DEVICE in appropriate BODY CONTROL MODULES article.
- 3) Select display DTC function for PCM. Record all displayed DTCs and status of displayed DTCs. If DTCs are displayed, go to next step. If no DTCs are displayed, see COMPRESSOR DOES NOT ENGAGE or COMPRESSOR DOES NOT DISENGAGE.
- 4) If scan tool does not display DTCs beginning with "U", see appropriate SELF-DIAGNOSTICS article in ENGINE PERFORMANCE. If scan tool displays DTCs beginning with "U", see SCAN TOOL DOES NOT COMMUNICATE WITH CLASS 2 DEVICE in appropriate BODY CONTROL MODULES article.

Compressor Does Not Engage

- 1) If diagnostic system check has not been performed, see DIAGNOSTIC SYSTEM CHECK. If diagnostic system check has been performed, go to next step.
- 2) Ensure outside air temperature is greater than 38°F (3°C). Start engine. Turn blower motor switch to maximum speed position. Place A/C switch in ON position. Place air temperature control switch in coldest position. If A/C compressor operates, problem is intermittent. If A/C compressor does not operate, go to next step.
- 3) Park vehicle inside or in shade. Open windows in order to ventilate interior of vehicle. If A/C system was operating, then allow A/C system to equalize for about 2 minutes. Turn ignition switch to OFF position. Install Refrigerant Station (J 43600 ACR 2000). Record outside air temperature at vehicle. Record readings of low and high

side static pressures. Compare pressure values with specifications for ambient air temperature. See PRESSURE-TEMPERATURE RELATIONSHIP article in GENERAL SERVICING. If pressure values are within specification for ambient air temperature and within 15 psi (1.1 kg/cm²) of each other, go to next step. If pressure values are not within specification for ambient air temperature or within 15 psi (1.1 kg/cm²) of each other, see LEAK TESTING article in GENERAL SERVICING.

4) Turn ignition switch to ON position, with engine off.

Using scan tool, observe A/C HIGH SIDE PRESSURE SENSOR parameter in POWERTRAIN data list. Compare A/C high side pressure on scan tool to high side pressure value on refrigerant station. If high side pressure values are within 15 psi (1.1 kg/cm²) of each other, go to next step. If high side pressure values are not within 15 psi (1.1 kg/cm²) of each other, go to step 18).

5) If HVAC control module is inoperative, go to step 17). If HVAC control module is not inoperative, go to next step.

6) Start engine. Using scan tool, observe A/C REQUEST parameter in ENGINE DATA 2 data list. Turn air temperature switch to coldest position. Turn blower motor to ON position. Place A/C request switch in ON position. If scan tool indicates A/C REQUEST parameter is ON, go to step 11). If scan tool does not indicate A/C REQUEST parameter is ON, go to next step.

7) If A/C request indicator illuminates, go to step 9). If A/C request indicator does not illuminate, go to next step.

8) Ensure blower motor switch is in ON position. Turn ignition switch to ON position. Check blower motor off circuit (Dark Green wire) at HVAC control assembly for short to voltage. If problem was found, repair as necessary. After repairs, go to step 36). If problem was not found, go to step 29).

9) Turn ignition switch to OFF position. Disconnect PCM. Turn ignition switch to ON position, with engine off. Turn air temperature switch to coldest position. Turn blower motor switch to maximum speed position. Place A/C request switch in ON position. Measure voltage between A/C request signal circuit (Dark Green/White wire) of PCM and ground. If voltage is 10-12.5 volts, go to step 30). If voltage is not 10-12.5 volts, go to next step.

10) Turn ignition switch to OFF position. Check A/C request signal circuit (Dark Green/White wire) for short to ground, high resistance, or open. If problem was found, repair as necessary. After repairs, go to step 36). If problem was not found, go to step 29).

11) Using scan tool, command A/C compressor clutch relay on and off. If A/C compressor clutch relay turns on and off with each command, go to step 15). If A/C compressor clutch relay does not turn on and off with each command, go to next step.

12) Turn ignition switch to OFF position. Disconnect A/C compressor clutch relay. Turn ignition switch to ON position, with engine off. Using test light connected to ground, probe coil side voltage supply circuit of A/C compressor clutch relay. If test light is on, go to next step. If test light is off, go to step 25).

13) Connect test light between control circuit (Dark Green/White wire) of A/C compressor clutch relay and coil side voltage supply circuit of A/C compressor clutch relay. Using scan tool, command A/C compressor clutch relay on and off. If test light turns on and off with each command, go to step 27). If test light does not turn on and off with each command, go to next step.

14) If test light remains on with each command, go to step 21). If test light does not remain on with each command, go to step 20).

15) Turn ignition switch to OFF position. Disconnect A/C compressor clutch relay. Using test light connected to ground, probe switch side voltage supply circuit of A/C compressor clutch relay. If test light is on, go to next step. If test light is off, go to step 24).

16) Connect fused jumper (10 amp) between switch side voltage circuit of A/C compressor clutch relay and A/C compressor clutch supply voltage circuit (Dark Green wire) of A/C compressor clutch. Turn ignition switch to ON position, with engine off. If A/C compressor clutch engages, go to step 27). If A/C compressor clutch does not engage, go to step 22).

17) Test ignition voltage circuit (Brown wire) of HVAC control module for short to ground, high resistance, or open. If problem was found, repair as necessary. After repairs, go to step 36). If problem was not found, go to step 19).

18) Check ground circuit (Black wire) of A/C refrigerant pressure sensor for open. If problem was found, repair as necessary. After repairs, go to step 36). If problem was not found, go to step 26).

19) Check ground circuit (Black wire) of HVAC control module for open. If problem was found, repair as necessary. After repairs, go to step 36). If problem was not found, go to step 29).

20) Check control circuit (Dark Green/White wire) of A/C compressor clutch relay for open. If problem was found, repair as necessary. After repairs, go to step 36). If problem was not found, go to step 30).

21) Check control circuit (Dark Green/White wire) of A/C compressor clutch relay for short to ground. If problem was found, repair as necessary. After repairs, go to step 36). If problem was not found, go to step 30).

22) Check A/C compressor clutch supply voltage circuit (Dark Green wire) at A/C compressor clutch for short to ground, high resistance, or open. If problem was found, repair as necessary. After repairs, go to step 36). If problem was not found, go to next step.

23) Check ground circuit (Black wire) of A/C compressor clutch for a high resistance or open. If problem was found, repair as necessary. After repairs, go to step 36). If problem was not found, go to step 28).

24) Repair switch side voltage supply circuit of A/C compressor clutch relay. After repairs, go to step 36).

25) Repair coil side voltage supply circuit of A/C compressor clutch relay. After repairs, go to step 36).

26) Check A/C refrigerant pressure sensor connector for poor connections. If problem was found, repair as necessary. After repairs, go to step 36). If problem was not found, go to step 31).

27) Check A/C compressor clutch relay connector for poor connections. If problem was found, repair as necessary. After repairs, go to step 36). If problem was not found, go to step 32).

28) Check A/C compressor clutch connector for poor connections. If problem was found, repair as necessary. After repairs, go to step 36). If problem was not found, go to step 33).

29) Check HVAC control module connector for poor connections. If problem was found, repair as necessary. After repairs, go to step 36). If problem was not found, go to step 34).

30) Check PCM connectors for poor connections. If problem was found, repair as necessary. After repairs, go to step 36). If problem was not found, go to step 35).

31) Replace A/C refrigerant pressure sensor. After repairs, go to step 36).

32) Replace A/C compressor clutch relay. After repairs, go to step 36).

33) Replace A/C compressor clutch coil. See appropriate COMPRESSOR SERVICING article in GENERAL SERVICING. After repairs, go to step 36).

34) Replace HVAC control module. See REMOVAL & INSTALLATION in appropriate MANUAL A/C-HEATER SYSTEMS article. After repairs, go to step 36).

35) Replace PCM. See appropriate REMOVAL, OVERHAUL &

INSTALLATION article in ENGINE PERFORMANCE. After repairs, go to next step.

36) Operate system to verify repair.

Compressor Does Not Disengage

1) If diagnostic system check has not been performed, see DIAGNOSTIC SYSTEM CHECK. If diagnostic system check has been performed, go to next step.

2) Start engine. Turn blower motor switch to OFF position. If A/C compressor operates, go to next step. If A/C compressor does not operate, problem is intermittent.

3) Using scan tool, observe A/C REQUEST parameter in ENGINE DATA 2 data list. If scan tool indicates A/C REQUEST parameter is ON, go to next step. If scan tool does not indicate A/C REQUEST parameter is ON, go to step 6).

4) Check A/C request signal circuit (Dark Green/White wire) for short to voltage. If problem was found, repair as necessary. After repairs, go to step 17). If problem was not found, go to next step.

5) Turn ignition switch to OFF position. Disconnect HVAC control module. Back out terminal for A/C request circuit (Dark Green/White wire) at HVAC control head. Start engine. Using scan tool, observe A/C REQUEST parameter. If scan tool indicates A/C REQUEST parameter is ON, go to step 12). If scan tool does not indicate A/C REQUEST parameter is ON, go to step 11).

6) Remove A/C compressor clutch relay. If A/C compressor clutch turns off, go to next step. If A/C compressor clutch does not turn off, go to step 9).

7) Measure resistance between switch side A/C compressor clutch relay terminals. If resistance is infinite, go to next step. If resistance is not infinite, go to step 10).

8) Check A/C clutch relay control circuit (Dark Green/White wire) for short to ground. If problem was found, repair as necessary. After repairs, go to step 17). If problem was not found, go to step 12).

9) Check A/C compressor clutch supply voltage circuit (Dark Green wire) for short to voltage. If problem was found, repair as necessary. After repairs, go to step 17). If problem was not found, go to step 14).

10) Check A/C compressor clutch relay connector for poor connections. If problem was found, repair as necessary. After repairs, go to step 17). If problem was not found, go to step 13).

11) Check HVAC control module connector for poor connections. If problem was found, repair as necessary. After repairs, go to step 17). If problem was not found, go to step 15).

12) Check PCM connectors for poor connections. If problem was found, repair as necessary. After repairs, go to step 17). If problem was not found, go to step 16).

13) Replace A/C compressor clutch relay. After repairs, go to step 17).

14) Replace A/C compressor clutch. See appropriate COMPRESSOR SERVICING article in GENERAL SERVICING. After repairs, go to step 17).

15) Replace HVAC control module. See REMOVAL & INSTALLATION in appropriate MANUAL A/C-HEATER SYSTEMS article. After repairs, go to step 17).

16) Replace PCM. See appropriate REMOVAL, OVERHAUL & INSTALLATION article in ENGINE PERFORMANCE. After repairs, go to next step.

17) Operate system to verify repair.

3.1L: LUMINA

NOTE: For circuit, wire color and terminal identification, see WIRING DIAGRAMS. Also see WIRING DIAGRAMS in appropriate

MANUAL or AUTOMATIC A/C HEATER SYSTEMS article.

Description

When A/C is selected through A/C controller, a 12.0 volt signal is supplied to A/C request input of PCM. A/C compressor clutch relay is controlled through PCM. PCM monitors A/C refrigerant pressure. If A/C refrigerant pressure and engine operating conditions are within a specific calibrated acceptable ranges, PCM will enable A/C compressor relay. This is accomplished by providing a ground path for A/C relay coil within PCM. When A/C compressor relay is enabled battery voltage is supplied to compressor clutch coil.

The PCM will disengage A/C compressor clutch if one or more of the following conditions occur:

- * Throttle angle is greater than 96 percent.
- * A/C head pressure is greater than 440 psi (31 kg/cm²) with A/C refrigerant pressure sensor reading greater than 4.27 volts.
- * A/C head pressure is less than 36 psi (2.5 kg/cm²) with A/C refrigerant pressure sensor reading less than .35 volts.
- * Ignition voltage is less than 10.0 volts.
- * Engine speed is greater than 4700 RPM for 5 seconds or at 5400 RPM for any amount of time.
- * Engine coolant temperature is greater than 255°F (124°C).
- * Intake air temperature is less than 41°F (5°C).

Diagnostic System Check

1) Install scan tool. If scan tool powers up, go to next step. If scan tool does not power up, see SCAN TOOL DOES NOT POWER UP in appropriate BODY CONTROL MODULES article.

2) Turn ignition on, engine off. Try to establish scan tool communication with Body Control Module (BCM) and Powertrain Control Module (PCM). If communication with BCM and PCM is established, go to next step. If communication with BCM or PCM is not established, see SCAN TOOL DOES NOT COMMUNICATE WITH CLASS 2 DEVICE in appropriate BODY CONTROL MODULES article.

3) Select display DTC function for BCM and PCM. Record all displayed DTCs and status of displayed DTCs. If DTCs are displayed, go to next step. If no DTCs are displayed, see DIAGNOSIS.

4) If scan tool displays DTCs beginning with "B", see appropriate SELF-DIAGNOSTICS article in BODY CONTROL MODULES. If scan tool displays DTCs beginning with "P", see appropriate SELF-DIAGNOSTICS article in ENGINE PERFORMANCE. If scan tool displays DTCs beginning with "U", see SCAN TOOL DOES NOT COMMUNICATE WITH CLASS 2 DEVICE in appropriate BODY CONTROL MODULES article.

Diagnosis

1) If diagnostic system check has not been performed, see DIAGNOSTIC SYSTEM CHECK. If diagnostic system check has been performed, go to next step.

NOTE: Before performing this step, ambient air temperature must be greater than 41°F (5°C), A/C pressure must be greater than 36 psi (2.5 kg/cm²) and coolant temperature must be less than 250°F (121°C).

2) Turn A/C selector switch to OFF position. Turn ignition switch to ON position, with engine off. Listen for engagement of A/C clutch. If A/C clutch engages, go to step 17). If A/C clutch does not engage, go to next step.

3) Start engine. Select DEFROST or MAX mode on HVAC control.

Observe A/C compressor. If A/C compressor clutch engages, see DIAGNOSTIC AIDS. If A/C clutch does not engage, go to next step.

4) With DEFROST or MAX mode selected, monitor A/C REQUEST display on scan tool in ENGINE data list. If A/C REQUEST displays YES, go to step 8). If A/C REQUEST does not display YES, go to next step.

5) Turn ignition switch to OFF position. Disconnect PCM. Turn ignition switch to ON position. With DEFROST or MAX mode selected, measure voltage between A/C request circuit (Light Green wire) at PCM harness connector and ground. If battery voltage is present, go to step 7). If battery voltage is not present, go to next step.

6) Check A/C request circuit (Light Green wire) for open, shorted to ground or poor connections. If problem was found, repair as necessary. After repair, go to step 28). If problem was found, see DIAGNOSTIC SYSTEM CHECK.

7) Check A/C request circuit (Light Green wire) for poor connection at PCM. If problem was found, repair as necessary. After repairs, go to step 28). If problem was not found, go to step 26).

8) Observe A/C REFRIGERANT PRESSURE display on scan tool. If A/C pressure is 36 - 440 psi (2.5-31 kg/cm²), go to step 11). If A/C pressure is not 36-440 psi (2.5-31 kg/cm²), go to next step.

9) Connect Manifold Gauge Set (J 39183-C R-134a). Observe high side refrigerant pressure on gauge. If high side refrigerant pressure is 36-440 psi (2.5-31 kg/cm²), go to next step. If high side refrigerant pressure is not 36-440 psi (2.5-31 kg/cm²), see DIAGNOSTIC SYSTEM CHECK.

10) Turn ignition switch to OFF position. Disconnect A/C Pressure sensor. Turn ignition switch to ON position. View A/C HIGHSIDE display on scan tool in ENGINE data list. If scan tool displays A/C HIGHSIDE pressure at zero psi, go to step 27). If scan tool does not display A/C HIGHSIDE pressure at zero psi, go to step 26).

11) Disconnect A/C relay connector. Using test light connected to ground, probe ignition feed circuits (Pink wires) at A/C relay connector. If test light is on, go to next step. If test light is off, go to step 22).

12) Connect fused jumper between ignition feed circuit (Pink wire) and A/C compressor clutch control circuit (Dark Green wire) at A/C relay connector. If A/C compressor clutch engages, go to next step. If A/C compressor clutch does not engage, go to step 14).

13) Check A/C relay connector for poor connections. If problem was found, repair as necessary. After repairs, go to step 28). If problem was not found, go to step 23).

14) Disconnect A/C compressor clutch connector (leave ignition control circuit and A/C compressor clutch control circuit jumpered at A/C relay connector). Connect test light between A/C compressor clutch feed circuit (Dark Green wire) and compressor ground circuit (Black wire). If test light is on, go to next step. If test light is off, go to step 16).

15) Check A/C compressor clutch connector for poor connections. If problem was found, repair as necessary. After repairs, go to step 28). If problem was not found, go to step 24).

16) Check A/C compressor clutch control circuit (Dark Green/White wire) for open or short to ground. If problem was found, repair as necessary. After repairs, go to step 28). If problem was not found, go to step 25).

17) Turn ignition switch to ON position. Turn A/C off. Observe A/C REQUEST display on scan tool. If A/C REQUEST displays YES, go to next step. If A/C REQUEST does not display YES, go to step 20).

18) Turn ignition switch to OFF position. Disconnect PCM. Turn ignition to ON position. Turn A/C off. Using DVOM, measure voltage between A/C request circuit (Light Green wire) at PCM connector and ground. If battery voltage is present, go to next step. If battery voltage is not present, go to step 26).

19) Turn ignition switch to OFF position. Disconnect A/C control head. Turn ignition switch to ON position. Check A/C request circuit (Light Green wire) for short to battery voltage. If problem was found, repair as necessary. After repairs, go to step 28). If problem was not found, see DIAGNOSTIC SYSTEM CHECK.

20) Disconnect A/C relay. Start vehicle and observe A/C compressor. If A/C compressor clutch engages, go to next step. If A/C compressor clutch does not engage, go to step 23).

21) Repair short to voltage in A/C compressor clutch control circuit (Dark Green/White wire). After repairs, go to step 28).

22) Repair open or short to ground in ignition feed circuit (Pink wire) to A/C compressor relay. After repairs, go to step 28).

23) Replace A/C compressor relay. After repairs, go to step 28).

24) Replace A/C compressor clutch. See appropriate COMPRESSOR SERVICING article in GENERAL SERVICING. After repairs, go to step 28).

25) Repair open in A/C compressor clutch ground circuit (Black wire). After repairs, go to step 28).

26) Replace PCM. See appropriate REMOVAL, OVERHAUL & INSTALLATION article in ENGINE PERFORMANCE. After repairs, go to step 28).

27) Replace A/C refrigerant pressure sensor. After repairs, go to next step.

NOTE: Before performing this step, ensure ambient air temperature is greater than 41°F (5°C), A/C pressure is greater than 36 psi (2.5 kg/cm²) and coolant temperature is less than 250°F (121°C).

28) Start engine. Turn A/C selector switch to ON position. Listen for engagement of A/C clutch. If A/C clutch engages, system is okay.

Diagnostic Aids

An intermittent condition may be caused by corrosion, misrouted wiring harness, rubbed through wire insulation or a wire broken inside insulation. Perform visual inspection and check for continuity along suspect circuits. Repair as necessary. If circuits are okay, check conditions listed under DESCRIPTION.

3.4L & 3.8L: IMPALA & MONTE CARLO

NOTE: For circuit, wire color and terminal identification, see WIRING DIAGRAMS. Also see WIRING DIAGRAMS in appropriate MANUAL or AUTOMATIC A/C HEATER SYSTEMS article.

Description

When A/C is selected through HVAC controller, a 12 volt signal is supplied to Body Control Module (BCM). BCM in turn signals PCM through Class 2 serial data circuit that A/C has been requested. PCM then determines if conditions suitable for A/C operation are present. If PCM determines that engine operating conditions are within acceptable ranges, PCM will enable A/C relay. PCM provides a ground path for A/C relay coil. This action closes A/C compressor relay contacts and battery voltage is supplied to compressor clutch coil. Compressor clutch coil has its own ground path.

PCM will enable A/C unless any of the following conditions are met:

- * Throttle position is more than 96 percent.
- * A/C pressure is more than 472 psi (4.9 volts) or less than 9 psi (0.1 volt) as determined by A/C pressure

sensor.

- * Ignition voltage is less than 10 volts.
- * Engine speed is more than 4700 RPM.
- * Engine Coolant Temperature (ECT) is more than 255°F (124°C).
- * Intake Air Temperature (IAT) is less than 41°F (5°C).
- * Class II communication error occurs between HVAC controller and PCM.

Diagnostic System Check

1) Install scan tool. If scan tool powers up, go to next step. If scan tool does not power up, see SCAN TOOL DOES NOT POWER UP in appropriate BODY CONTROL MODULES article.

2) Turn ignition on, engine off. Try to establish scan tool communication with Powertrain Control Module (PCM). If communication with PCM is established, go to next step. If communication with PCM is not established, see SCAN TOOL DOES NOT COMMUNICATE WITH CLASS 2 DEVICE in appropriate BODY CONTROL MODULES article.

3) Select display DTC function for PCM. Record all displayed DTCs and status of displayed DTCs. If DTCs are displayed, go to next step. If no DTCs are displayed, see COMPRESSOR CLUTCH DOES NOT ENGAGE or COMPRESSOR CLUTCH DOES NOT DISENGAGE.

4) If scan tool does not display DTCs beginning with "U", see appropriate SELF-DIAGNOSTICS article in ENGINE PERFORMANCE. If scan tool displays DTCs beginning with "U", see SCAN TOOL DOES NOT COMMUNICATE WITH CLASS 2 DEVICE in appropriate BODY CONTROL MODULES article.

Compressor Clutch Does Not Engage

1) If diagnostic system check has not been performed, see DIAGNOSTIC SYSTEM CHECK. If diagnostic system check has been performed, go to next step.

2) Ensure outside air temperature is greater than 38°F (3°C). Start engine. Turn blower motor switch to maximum speed position. Place A/C switch in ON position. Place air temperature control switch in coldest position. If A/C compressor operates, problem is intermittent. If A/C compressor does not operate, go to next step.

3) Park vehicle inside or in shade. Open windows in order to ventilate interior of vehicle. If A/C system was operating, then allow A/C system to equalize for about 2 minutes. Turn ignition switch to OFF position. Install Refrigerant Station (J 43600 ACR 2000). Record outside air temperature at vehicle. Record readings of low and high side static pressures. Compare pressure values with specifications for ambient air temperature. See PRESSURE-TEMPERATURE RELATIONSHIP article in GENERAL SERVICING. If pressure values are within specification for ambient air temperature and within 15 psi (1.1 kg/cm²) of each other, go to next step. If pressure values are not within specification for ambient air temperature or within 15 psi (1.1 kg/cm²) of each other, see LEAK TESTING article in GENERAL SERVICING.

4) Turn ignition switch to ON position, with engine off. Using scan tool, observe A/C HIGH SIDE PRESSURE SENSOR parameter in POWERTRAIN data list. Compare A/C high side pressure on scan tool to high side pressure value on refrigerant station. If high side pressure values are within 15 psi (1.1 kg/cm²) of each other, go to next step. If high side pressure values are not within 15 psi (1.1 kg/cm²) of each other, go to step 18).

5) If HVAC control assembly is inoperative, go to step 9). If HVAC control assembly is not inoperative, go to next step.

6) Start engine. Using scan tool, observe A/C REQUEST SIGNAL parameter in POWERTRAIN DATA LIST 2. Turn blower motor switch to maximum speed position. Turn mode switch to MAX air position. Place A/C switch in ON position. If scan tool indicates A/C REQUEST parameter is YES, go to next step. If scan tool does not indicate A/C

REQUEST parameter is YES, go to step 11).

7) Using scan tool, observe COMMANDED A/C parameter in POWERTRAIN DATA LIST 2. If scan tool indicates COMMANDED A/C parameter is ON, go to next step. If scan tool does not indicate COMMANDED A/C parameter is ON, go to step 28).

8) Using scan tool, command A/C compressor clutch relay on and off. If A/C compressor clutch relay turns on and off with each command, go to step 12). If A/C compressor clutch relay does not turn on and off with each command, go to step 14).

9) Check ignition voltage circuit (Brown wire) to HVAC control assembly for short to ground, high resistance, or open. If problem was found, repair as necessary. After repairs, go to step 35). If problem was not found, go to next step.

10) Check ground circuit (Black wire) to HVAC control assembly for open. If problem was found, repair as necessary. After repairs, go to step 35). If problem was not found, go to step 26).

11) Using scan tool, observe A/C SWITCH parameter in BCM INPUTS. If scan tool indicates A/C SWITCH parameter is ON, go to step 27). If scan tool does not indicate A/C SWITCH parameter is ON, go to step 16).

12) Turn ignition switch to OFF position. Disconnect A/C compressor clutch relay. Using test light connected to ground, probe switch side voltage supply circuit (Orange wire) of A/C compressor clutch relay. If test light is on, go to next step. If test light is off, go to step 21).

13) Connect fused jumper (10 amp) between switch side voltage circuit (Orange wire) of A/C compressor clutch relay and A/C compressor clutch supply voltage circuit (Dark Green wire) of A/C compressor clutch. If A/C compressor clutch engages, go to step 24). If A/C compressor clutch does not engage, go to step 17).

14) Turn ignition switch to OFF position. Disconnect A/C compressor clutch relay. Turn ignition switch to ON position, with engine off. Using test light connected to ground, probe coil side voltage supply circuit (Pink wire) of A/C compressor clutch relay. If test light is on, go to next step. If test light is off, go to step 20).

15) Connect test light between control circuit (Dark Green/White wire) of A/C compressor clutch relay and coil side voltage supply circuit (Pink wire) of A/C compressor clutch relay. Using scan tool, command A/C compressor clutch relay on and off. If test light turns on and off with each command, go to step 24). If test light does not turn on and off with each command, go to step 22).

16) Check A/C request signal circuit (Dark Green/White) for short to ground, high resistance, or open. If problem was found, repair as necessary. After repairs, go to step 35). If problem was not found, go to step 26).

17) Check A/C compressor clutch supply voltage circuit (Dark Green wire) at A/C compressor clutch for short to ground, high resistance, or open. If problem was found, repair as necessary. After repairs, go to step 35). If problem was not found, go to step 19).

18) Check ground circuit (Black wire) of A/C pressure sensor for open. If problem was found, repair as necessary. After repairs, go to step 35). If problem was not found, go to step 23).

19) Check ground circuit (Black wire) of A/C compressor clutch for high resistance or open. If problem was found, repair as necessary. After repairs, go to step 35). If problem was not found, go to step 25).

20) Repair coil side voltage supply circuit (Pink wire) of A/C compressor clutch relay. After repairs, go to step 35).

21) Repair switch side voltage supply circuit (Orange wire) of A/C compressor clutch relay. After repairs, go to step 35).

22) Check control circuit (Dark Green/White wire) of A/C compressor clutch relay for open, or short to ground. If problem was

found, repair as necessary. After repairs, go to step 35). If problem was not found, go to step 28).

23) Check A/C high pressure sensor connector for poor connections. If problem was found, repair as necessary. After repairs, go to step 35). If problem was not found, go to step 29).

24) Check A/C compressor clutch relay connector for poor connections. If problem was found, repair as necessary. After repairs, go to step 35). If problem was not found, go to step 30).

25) Check A/C compressor clutch coil connector for poor connections. If problem was found, repair as necessary. After repairs, go to step 35). If problem was not found, go to step 31).

26) Check HVAC control assembly connector for poor connections. If problem was found, repair as necessary. After repairs, go to step 35). If problem was not found, go to step 32).

27) Check BCM connectors for poor connections. If problem was found, repair as necessary. After repairs, go to step 35). If problem was not found, go to step 33).

28) Check PCM connectors for poor connections. If problem was found, repair as necessary. After repairs, go to step 35). If problem was not found, go to step 34).

29) Replace A/C high pressure switch. After repairs, go to step 35).

30) Replace A/C compressor clutch relay. After repairs, go to step 35).

31) Replace A/C compressor clutch coil. See appropriate COMPRESSOR SERVICING article in GENERAL SERVICING. After repairs, go to step 35).

32) Replace HVAC control assembly. See REMOVAL & INSTALLATION in appropriate MANUAL A/C-HEATER SYSTEMS article. After repairs, go to step 35).

33) Replace BCM. See REMOVAL & INSTALLATION in appropriate BODY CONTROL MODULES article. After repairs, go to step 35).

34) Replace PCM. See appropriate REMOVAL, OVERHAUL & INSTALLATION article in ENGINE PERFORMANCE. After repairs, go to next step.

35) Operate system to verify repair.

Compressor Clutch Does Not Disengage

1) If diagnostic system check has not been performed, see DIAGNOSTIC SYSTEM CHECK. If diagnostic system check has been performed, go to next step.

2) Start engine. Turn blower motor switch to OFF position. Place A/C request switch in OFF position. If A/C compressor operates, go to next step. If A/C compressor does not operate, problem is intermittent.

3) Using scan tool, observe A/C REQUEST parameter in POWERTRAIN DATA LIST 2. If scan tool indicates A/C REQUEST parameter is OFF, go to next step. If A/C REQUEST parameter is not OFF, go to step 6).

4) Using scan tool, observe COMMANDED A/C parameter in POWERTRAIN DATA LIST 2. If scan tool indicates COMMANDED A/C parameter is OFF, go to next step. If scan tool does not indicate A/C COMMAND parameter is OFF, go to step 14).

5) Check control circuit (Dark Green wire) of A/C compressor clutch relay for short to ground. If problem was found, repair as necessary. After repairs, go to step 20). If problem was not found, go to step 7).

6) Using scan tool, observe A/C SWITCH parameter in BCM INPUTS. If scan tool indicates A/C SWITCH parameter is ON, go to step 9). If scan tool does not indicate A/C SWITCH parameter is ON, go to step 13).

7) Remove A/C compressor clutch relay. If A/C compressor clutch turns off, go to step 10). If A/C compressor clutch does not

turn off, go to next step.

8) Check A/C compressor clutch voltage supply circuit (Dark Green wire) at A/C compressor clutch for short to voltage. If problem was found, repair as necessary. After repairs, go to step 20). If problem was not found, go to step 11).

9) Check A/C request signal circuit (Dark Green/White wire) for short to ground, high resistance, or open. If problem was found, repair as necessary. After repairs, go to step 20). If problem was not found, go to step 12).

10) Check A/C compressor clutch relay connector for poor connections. If problem was found, repair as necessary. After repairs, go to step 20). If problem was not found, go to step 15).

11) Check A/C compressor clutch connector for poor connections. If problem was found, repair as necessary. After repairs, go to step 20). If problem was not found, go to step 16).

12) Check HVAC control assembly connector for poor connections. If problem was found, repair as necessary. After repairs, go to step 20). If problem was not found, go to step 17).

13) Check BCM connectors for poor connections. If problem was found, repair as necessary. After repairs, go to step 20). If problem was not found, go to step 18).

14) Check PCM connectors for poor connections. If problem was found, repair as necessary. After repairs, go to step 20). If problem was not found, go to step 19).

15) Replace A/C compressor clutch relay. After repairs, go to step 20).

16) Replace A/C compressor clutch. See appropriate COMPRESSOR SERVICING article in GENERAL SERVICING. After repairs, go to step 20).

17) Replace HVAC control assembly. See REMOVAL & INSTALLATION in appropriate MANUAL A/C-HEATER SYSTEMS article. After repairs, go to step 20).

18) Replace BCM. See REMOVAL & INSTALLATION in appropriate BODY CONTROL MODULES article. After repairs, go to step 20).

19) Replace PCM. See appropriate REMOVAL, OVERHAUL & INSTALLATION article in ENGINE PERFORMANCE. After repairs, go to next step.

20) Operate system to verify repair.

3.5L & 4.0L: AURORA

NOTE: For circuit, wire color and terminal identification, see WIRING DIAGRAMS. Also see WIRING DIAGRAMS in appropriate MANUAL or AUTOMATIC A/C HEATER SYSTEMS article.

Description

The purpose of the air conditioning (A/C) system is to provide cool air and remove humidity from interior of vehicle. A/C system is engaged when HVAC control module is in any mode except OFF and VENT. A/C system can operate regardless of temperature setting, as long as ambient temperature is greater than 38°F (3°C). If A/C compressor is turned off due to low ambient temperatures, compressor will not be activated until temperatures reach 42°F (6°C). Vehicle passenger can adjust temperature offset by adjusting right air temperature switch assembly. Passenger temperatures can be set 8°F (4°C) cooler or warmer than drivers setting.

HVAC control module is interface between vehicle operator and Instrument Panel Module (IPM). HVAC control module receives power from rear fuse block on ignition 3 voltage circuit. IPM is also powered from rear fuse block through ignition 3 voltage circuit along with battery positive voltage circuit. IPM and HVAC control module communicate back and forth over HVAC control module signal and HVAC control module clock signal circuits.

In order for Powertrain Control Module (PCM) to internally ground A/C compressor clutch relay control circuit, Dash Integration Module (DIM) and PCM must communicate with each other over class 2 serial data circuits. PCM monitors A/C refrigerant line pressure and engine coolant temperature. This information is placed on class 2 serial data circuit and is monitored by DIM. DIM looks at A/C line pressure, engine coolant temperature, battery voltage along with A/C request input from IPM. DIM will request A/C operation from PCM if these parameters are within normal operating limits and IPM is requesting A/C operation.

PCM turns on A/C compressor by providing a path to ground through A/C compressor clutch relay control circuit for A/C compressor clutch relay. Power is provided to A/C compressor clutch relay internally within underhood fuse block. Once relay closes its internal switch, power from battery is provided to A/C compressor clutch through A/C compressor clutch supply voltage circuit. Whenever compressor is turned off, A/C compressor clutch diode provides a path for voltage spike resulting from collapsing magnetic field of the compressor clutch coil. Ground circuit provides a path to ground for compressor. A/C clutch relay control circuit is grounded internally within PCM.

Diagnostic System Check

1) Install scan tool. If scan tool powers up, go to next step. If scan tool does not power up, see SCAN TOOL DOES NOT POWER UP in appropriate BODY CONTROL MODULES article.

2) Turn ignition on, engine off. Try to establish scan tool communication with Body Control Module (BCM), Dash Integration Module (DIM), Instrument Panel Module (IPM) and Powertrain Control Module (PCM). If communication with all modules is established, go to next step. If communication with all modules is not established, see SCAN TOOL DOES NOT COMMUNICATE WITH CLASS 2 DEVICE in appropriate BODY CONTROL MODULES article.

3) Select display DTC function for each module. Record all displayed DTCs, status of displayed DTCs and which module set DTCs. If DTCs are displayed, go to next step. If no DTCs are displayed, see COMPRESSOR CLUTCH DOES NOT ENGAGE or COMPRESSOR CLUTCH DOES NOT DISENGAGE.

4) If scan tool displays DTCs beginning with "B", see appropriate SELF-DIAGNOSTICS article in BODY CONTROL MODULES. If scan tool displays DTCs beginning with "P", see appropriate SELF-DIAGNOSTICS article in ENGINE PERFORMANCE. If scan tool displays DTCs beginning with "U", see SCAN TOOL DOES NOT COMMUNICATE WITH CLASS 2 DEVICE in appropriate BODY CONTROL MODULES article.

Compressor Clutch Does Not Engage

1) If diagnostic system check has not been performed, see DIAGNOSTIC SYSTEM CHECK. If diagnostic system check has been performed, go to next step.

2) Ensure outside air temperature is greater than 38°F (3°C). Start engine. Turn blower motor switch to maximum speed position. Place mode switch in DEFROST position. Place air temperature control switch in coldest position. If A/C compressor operates, problem is intermittent. If A/C compressor does not operate, go to next step.

3) Park vehicle inside or in shade. Open windows in order to ventilate interior of vehicle. If A/C system was operating, then allow A/C system to equalize for about 2 minutes. Turn ignition switch to OFF position. Install Refrigerant Station (J 43600 ACR 2000). Record outside air temperature at vehicle. Record readings of low and high side static pressures. Compare pressure values with specifications for ambient air temperature. See PRESSURE-TEMPERATURE RELATIONSHIP article

in GENERAL SERVICING. If pressure values are within specification for ambient air temperature and within 15 psi (1.1 kg/cm²) of each other, go to next step. If pressure values are not within specification for ambient air temperature or within 15 psi (1.1 kg/cm²) of each other, see LEAK TESTING article in GENERAL SERVICING.

4) Turn ignition switch to ON position, with engine off. Using scan tool, observe A/C HIGH SIDE PRESSURE SENSOR parameter in POWERTRAIN data list. Compare A/C high side pressure on scan tool to high side pressure value on refrigerant station. If high side pressure values are within 15 psi (1.1 kg/cm²) of each other, go to next step. If high side pressure values are not within 15 psi (1.1 kg/cm²) of each other, go to step 20).

5) If HVAC control module is inoperative, go to step 19). If HVAC control module is not inoperative, go to next step.

6) Start engine. Using scan tool, observe COMMANDED A/C parameter in POWERTRAIN data list. Turn air temperature switch to coldest position. If scan tool indicates COMMANDED A/C parameter is ON, go to step 13). If scan tool does not indicate COMMANDED A/C parameter is ON, go to next step.

7) Using scan tool, observe A/C CLUTCH (DESIRED) parameter in DIM A/C INFORMATION list. If scan tool indicates A/C CLUTCH (DESIRED) parameter is ON, go to next step. If scan tool does not indicate A/C CLUTCH (DESIRED) parameter is ON, go to step 9).

8) Using scan tool, observe A/C CLUTCH (ACTUAL) parameter in DIM A/C INFORMATION list. If scan tool indicates A/C CLUTCH (ACTUAL) parameter is ON, go to step 13). If scan tool does not indicate A/C CLUTCH (ACTUAL) parameter is ON, go to step 34).

9) Using scan tool, observe CONTROL HEAD (DESIRED) parameter in DIM A/C INFORMATION list. If scan tool indicates CONTROL HEAD (DESIRED) parameter is ON, go to next step. If scan tool does not indicate CONTROL HEAD (DESIRED) parameter is ON, go to step 12).

10) Using scan tool, observe PRESSURE STATUS parameter in DIM A/C INFORMATION list. If scan tool indicates PRESSURE STATUS parameter is NORMAL, go to next step. If scan tool does not indicate PRESSURE STATUS parameter is NORMAL, problem is intermittent.

11) Using scan tool, observe TEMPERATURE STATUS parameter in DIM A/C INFORMATION list. If scan tool indicates TEMPERATURE STATUS parameter is OK, go to step 31). If scan tool does not indicate TEMPERATURE STATUS parameter is OK, check engine for overheating.

12) Using scan tool, observe A/C CONTROL HEAD (DESIRED) parameter in DIM A/C INFORMATION list. Turn mode switch to and from DEFROST position. If scan tool indicates A/C CONTROL HEAD (DESIRED) parameter turns on and off with each command, go to step 30). If scan tool does not indicate A/C CONTROL HEAD (DESIRED) parameter turns on and off with each command, go to step 33).

13) Using scan tool, command A/C compressor clutch relay on and off. If A/C compressor clutch relay turns on and off with each command, go to step 17). If A/C compressor clutch relay does not turn on and off with each command, go to next step.

14) Turn ignition switch to OFF position. Disconnect A/C compressor clutch relay. Turn ignition switch to ON position, with engine off. Using test light connected to ground, probe coil side voltage supply circuit of A/C compressor clutch relay. If test light is on, go to next step. If test light is off, go to step 27).

15) Connect test light between control circuit (Dark Green/White wire) of A/C compressor clutch relay and coil side voltage supply circuit of A/C compressor clutch relay. Using scan tool, command A/C compressor clutch relay on and off. If test light turns on and off with each command, go to step 29). If test light does not turn on and off with each command, go to next step.

16) If test light remains on with each command, go to step 23). If test light does not remain on with each command, go to step 22).

17) Turn ignition switch to OFF position. Disconnect A/C compressor clutch relay. Using test light connected to ground, probe switch side voltage supply circuit of A/C compressor clutch relay. If test light is on, go to next step. If test light is off, go to step 26).

18) Connect fused jumper (10 amp) between switch side voltage circuit of A/C compressor clutch relay and A/C compressor clutch supply voltage circuit (Dark Green wire) of A/C compressor clutch. Turn ignition switch to ON position, with engine off. If A/C compressor clutch engages, go to step 29). If A/C compressor clutch does not engage, go to step 24).

19) Check ignition voltage circuit (Brown wire and Orange wire) of HVAC control module for short to ground, high resistance, or open. If problem was found, repair as necessary. After repairs, go to step 42). If problem was not found, go to step 21).

20) Check ground circuit (Black wire) of A/C pressure sensor for open. If problem was found, repair as necessary. After repairs, go to step 42). If problem was not found, go to step 28).

21) Check ground circuit (Black wire) of HVAC control module for open. If problem was found, repair as necessary. After repairs, go to step 42). If problem was not found, go to step 33).

22) Check control circuit (Dark Green/White wire) of A/C compressor clutch relay for open. If problem was found, repair as necessary. After repairs, go to step 42). If problem was not found, go to step 34).

23) Check control circuit (Dark Green/White wire) of A/C compressor clutch relay for short to ground. If problem was found, repair as necessary. After repairs, go to step 42). If problem was not found, go to step 34).

24) Check A/C compressor clutch supply voltage circuit (Dark Green wire) at A/C compressor clutch for short to ground, high resistance, or open. If problem was found, repair as necessary. After repairs, go to step 42). If problem was not found, go to next step.

25) Check ground circuit (Black wire) of A/C compressor clutch for high resistance or open. If problem was found, repair as necessary. After repairs, go to step 42). If problem was not found, go to step 32).

26) Repair switch side voltage supply circuit of A/C compressor clutch relay. After repairs, go to step 42).

27) Repair coil side voltage supply circuit of A/C compressor clutch relay. After repairs, go to step 42).

28) Check A/C high pressure sensor connector for poor connections. If problem was found, repair as necessary. After repairs, go to step 42). If problem was not found, go to step 37).

29) Check A/C compressor clutch relay connector for poor connections. If problem was found, repair as necessary. After repairs, go to step 42). If problem was not found, go to step 38).

30) Check IPM connector for poor connections. If problem was found, repair as necessary. After repairs, go to step 42). If problem was not found, go to step 35).

31) Check DIM connector for poor connections. If problem was found, repair as necessary. After repairs, go to step 42). If problem was not found, go to step 36).

32) Check A/C compressor clutch connector for poor connections. If problem was found, repair as necessary. After repairs, go to step 42). If problem was not found, go to step 39).

33) Check HVAC control module connector for poor connections. If problem was found, repair as necessary. After repairs, go to step 42). If problem was not found, go to step 40).

34) Check PCM connectors for poor connections. If problem was found, repair as necessary. After repairs, go to step 42). If problem was not found, go to step 41).

35) Replace IPM. See appropriate INSTRUMENT PANELS article in

ACCESSORIES & EQUIPMENT. After repairs, go to step 42).

36) Replace DIM. See REMOVAL & INSTALLATION in appropriate BODY CONTROL MODULES article. After repairs, go to step 42).

37) Replace A/C high pressure switch. After repairs, go to step 42).

38) Replace A/C compressor clutch relay. After repairs, go to step 42).

39) Replace A/C compressor. See appropriate COMPRESSOR SERVICING article in GENERAL SERVICING. After repairs, go to step 42).

40) Replace HVAC control module. See REMOVAL & INSTALLATION in appropriate AUTOMATIC A/C-HEATER SYSTEMS article. After repairs, go to step 42).

41) Replace PCM. See appropriate REMOVAL, OVERHAUL & INSTALLATION article in ENGINE PERFORMANCE. After repairs, go to next step.

42) Operate system to verify repair.

Compressor Clutch Does Not Disengage

1) If diagnostic system check has not been performed, see DIAGNOSTIC SYSTEM CHECK. If diagnostic system check has been performed, go to next step.

2) Install scan tool. Turn ignition switch to ON position, with engine off. Using scan tool, command A/C relay on and off. If A/C compressor clutch engages and disengages with each command, go to next step. If A/C compressor clutch does not engage and disengage with each command, go to step 7).

3) Start engine. Place A/C request switch in OFF position. Using scan tool, observe COMMANDED A/C parameter in PCM ENGINE data list. If scan tool displays OFF, go to step 12). If scan tool does not display OFF, go to next step.

4) Using scan tool, observe CONTROL HEAD (DESIRED) parameter in DIM A/C INFORMATION list. If scan tool displays A/C OFF, go to next step. If scan tool does not display A/C OFF, go to step 6).

5) Using scan tool, observe A/C CLUTCH (DESIRED) parameter in DIM A/C INFORMATION list. If scan tool displays OFF, go to step 12). If scan tool does not display OFF, go to step 11).

6) Using scan tool, observe A/C REQUESTED parameter in IPM HVAC SYSTEM data list. If scan tool displays NO, go to step 11). If scan tool does not display NO, go to step 10).

7) Turn ignition switch to OFF position. Disconnect A/C compressor clutch relay. Turn ignition switch to ON position, with engine off. If A/C compressor clutch disengages, go to step 13). If A/C compressor clutch does not disengage, go to next step.

8) Disconnect A/C compressor. If A/C compressor clutch disengages, go to next step. If A/C compressor clutch does not disengage, go to step 14).

9) Repair short to voltage in A/C compressor clutch supply voltage circuit (Dark Green wire) of A/C relay. After repairs, go to step 18).

10) Check IPM connector for poor connections. If problem was found, repair as necessary. After repairs, go to step 18). If problem was not found, go to step 15).

11) Check DIM connector for poor connections. If problem was found, repair as necessary. After repairs, go to step 18). If problem was not found, go to step 16).

12) Check PCM connectors for poor connections. If problem was found, repair as necessary. After repairs, go to step 18). If problem was not found, go to step 17).

13) Replace A/C compressor clutch relay. After repairs, go to step 18).

14) Replace A/C compressor. See appropriate COMPRESSOR SERVICING article in GENERAL SERVICING. After repairs, go to step 18).

15) Replace IPM. See appropriate INSTRUMENT PANELS article in

ACCESSORIES & EQUIPMENT. After repairs, go to step 18).

16) Replace DIM. See REMOVAL & INSTALLATION in appropriate BODY CONTROL MODULES article. After repairs, go to step 18).

17) Replace PCM. See appropriate REMOVAL, OVERHAUL & INSTALLATION article in ENGINE PERFORMANCE. After repairs, go to next step.

18) Operate system to verify repair.

Diagnostic Aids

An intermittent condition may be caused by corrosion, misrouted wiring harness, rubbed through wire insulation or a wire broken inside insulation. Perform visual inspection and check for continuity along suspect circuits. Repair as necessary.

3.8L: BONNEVILLE & LESABRE

NOTE: For circuit, wire color and terminal identification, see WIRING DIAGRAMS. Also see WIRING DIAGRAMS in appropriate MANUAL or AUTOMATIC A/C HEATER SYSTEMS article.

Description

Compressor for air conditioning system is belt-driven by engine through A/C compressor clutch. Clutch controls compressor in the following ways:

- * Disengages when air conditioning is not requested.
- * Disengages when engine load must be reduced.

Heater and A/C control automatically requests A/C compressor clutch engagement with system operating in defrost mode.

Under normal operating conditions, the following events occur:

- * On Bonneville and LeSabre with manual A/C, A/C-heater control sends an A/C operation desired message to Dash Integration Module (DIM), DIM sends a request A/C compressor clutch engagement to Powertrain Control Module (PCM)
- * On Bonneville and LeSabre with automatic A/C, Instrument Panel Module (IPM) sends an A/C operation desired message to Dash Integration Module (DIM), DIM sends a request for A/C compressor clutch engagement to Powertrain Control Module (PCM)
- * On all models, PCM supplies a ground to A/C compressor control relay coil.
- * A/C CLU relay energizes.
- * Voltage is supplied to A/C compressor clutch through A/C CLU fuse.
- * A/C compressor clutch engages and compressor runs.

PCM monitors A/C refrigerant line pressure and engine coolant temperature. This information is placed on Class 2 communication link and is monitored by DIM. DIM looks at A/C line pressure, engine coolant temperature and battery voltage. DIM will request A/C operation from PCM if these parameters are within normal operation limits and A/C-heater control is requesting A/C operation.

If PCM determines that engine load should be reduced, such as during full throttle conditions, PCM will de-energize A/C compressor control relay. This will disengage compressor, even though request for A/C compressor clutch engagement from A/C-heater control is still present.

A/C compressor clutch diode is connected across A/C compressor clutch terminals. This diode provides a path for current resulting from voltage spikes. Collapsing magnetic field of A/C compressor clutch coil generate these voltage spikes. Voltage spikes occur every time coil is de-energized.

Diagnostic System Check (Automatic A/C)

1) Install scan tool. If scan tool powers up, go to next step. If scan tool does not power up, see SCAN TOOL DOES NOT POWER UP in appropriate BODY CONTROL MODULES article.

2) Turn ignition on, engine off. Try to establish scan tool communication with Dash Integration Module (DIM), Instrument Panel Module (IPM) and Powertrain Control Module (PCM). If communication with all modules is established, go to next step. If communication with all modules is not established, see SCAN TOOL DOES NOT COMMUNICATE WITH CLASS 2 DEVICE in appropriate BODY CONTROL MODULES article.

3) Select display DTC function for each module. Record all displayed DTCs, status of displayed DTCs and which module set DTCs. If DTCs are displayed, go to next step. If no DTCs are displayed, see COMPRESSOR CLUTCH DOES NOT DISENGAGE (AUTOMATIC A/C) or COMPRESSOR CLUTCH DOES NOT DISENGAGE (AUTOMATIC A/C).

4) If scan tool displays DTCs beginning with "B", see appropriate SELF-DIAGNOSTICS article in BODY CONTROL MODULES. If scan tool displays DTCs beginning with "P", see appropriate SELF-DIAGNOSTICS article in ENGINE PERFORMANCE. If scan tool displays DTCs beginning with "U", see SCAN TOOL DOES NOT COMMUNICATE WITH CLASS 2 DEVICE in appropriate BODY CONTROL MODULES article.

Diagnostic System Check (Manual A/C)

1) Install scan tool. If scan tool powers up, go to next step. If scan tool does not power up, see SCAN TOOL DOES NOT POWER UP in appropriate BODY CONTROL MODULES article.

2) Turn ignition on, engine off. Try to establish scan tool communication with A/C-heater control module, Dash Integration Module (DIM) and Powertrain Control Module (PCM). If communication with all modules is established, go to next step. If communication with all modules is not established, see SCAN TOOL DOES NOT COMMUNICATE WITH CLASS 2 DEVICE in appropriate BODY CONTROL MODULES article.

3) Select display DTC function for each module. Record all displayed DTCs, status of displayed DTCs and which module set DTCs. If DTCs are displayed, go to next step. If no DTCs are displayed, see COMPRESSOR CLUTCH DOES NOT ENGAGE (MANUAL A/C) or COMPRESSOR CLUTCH DOES NOT DISENGAGE (MANUAL A/C).

4) If scan tool displays DTCs beginning with "B", see appropriate SELF-DIAGNOSTICS article in BODY CONTROL MODULES. If scan tool displays DTCs beginning with "P", see appropriate SELF-DIAGNOSTICS article in ENGINE PERFORMANCE. If scan tool displays DTCs beginning with "U", see SCAN TOOL DOES NOT COMMUNICATE WITH CLASS 2 DEVICE in appropriate BODY CONTROL MODULES article.

Compressor Clutch Does Not Engage (Automatic A/C)

1) If diagnostic system check has not been performed, see DIAGNOSTIC SYSTEM CHECK (AUTOMATIC A/C). If diagnostic system check has been performed, go to next step.

2) Ensure outside air temperature is greater than 38°F (3°C). Start engine. Turn blower motor switch to maximum speed position. Place mode switch in DEFROST position. Place air temperature control switch in coldest position. If A/C compressor operates, problem is intermittent. If A/C compressor does not operate, go to next step.

3) Park vehicle inside or in shade. Open windows in order to ventilate interior of vehicle. If A/C system was operating, then allow A/C system to equalize for about 2 minutes. Turn ignition switch to

OFF position. Install Refrigerant Station (J 43600 ACR 2000). Record outside air temperature at vehicle. Record readings of low and high side static pressures. Compare pressure values with specifications for ambient air temperature. See PRESSURE-TEMPERATURE RELATIONSHIP article in GENERAL SERVICING. If pressure values are within specification for ambient air temperature and within 15 psi (1.1 kg/cm²) of each other, go to next step. If pressure values are not within specification for ambient air temperature or within 15 psi (1.1 kg/cm²) of each other, see LEAK TESTING article in GENERAL SERVICING.

4) Turn ignition switch to ON position, with engine off. Using scan tool, observe A/C HIGH SIDE PRESSURE SENSOR parameter in POWERTRAIN data list. Compare A/C high side pressure on scan tool to high side pressure value on refrigerant station. If high side pressure values are within 15 psi (1.1 kg/cm²) of each other, go to next step. If high side pressure values are not within 15 psi (1.1 kg/cm²) of each other, go to step 20).

5) If HVAC control module is inoperative, go to step 19). If HVAC control module is not inoperative, go to next step.

6) Start engine. Using scan tool, observe COMMANDED A/C parameter in POWERTRAIN data list. Turn air temperature switch to coldest position. If scan tool indicates COMMANDED A/C parameter is ON, go to step 13). If scan tool does not indicate COMMANDED A/C parameter is ON, go to next step.

7) Using scan tool, observe A/C CLUTCH (DESIRED) parameter in DIM A/C INFORMATION list. If scan tool indicates A/C CLUTCH (DESIRED) parameter is ON, go to next step. If scan tool does not indicate A/C CLUTCH (DESIRED) parameter is ON, go to step 9).

8) Using scan tool, observe A/C CLUTCH (ACTUAL) parameter in DIM A/C INFORMATION list. If scan tool indicates A/C CLUTCH (ACTUAL) parameter is ON, go to step 13). If scan tool does not indicate A/C CLUTCH (ACTUAL) parameter is ON, go to step 34).

9) Using scan tool, observe CONTROL HEAD (DESIRED) parameter in DIM A/C INFORMATION list. If scan tool indicates CONTROL HEAD (DESIRED) parameter is ON, go to next step. If scan tool does not indicate CONTROL HEAD (DESIRED) parameter is ON, go to step 12).

10) Using scan tool, observe PRESSURE STATUS parameter in DIM A/C INFORMATION list. If scan tool indicates PRESSURE STATUS parameter is NORMAL, go to next step. If scan tool does not indicate PRESSURE STATUS parameter is NORMAL, problem is intermittent.

11) Using scan tool, observe TEMPERATURE STATUS parameter in DIM A/C INFORMATION list. If scan tool indicates TEMPERATURE STATUS parameter is okay, go to step 31). If scan tool does not indicate TEMPERATURE STATUS parameter is okay, check engine for overheating.

12) Using scan tool, observe A/C CONTROL HEAD (DESIRED) parameter in DIM A/C INFORMATION list. Turn mode switch to and from DEFROST position. If scan tool indicates A/C CONTROL HEAD (DESIRED) parameter turns on and off with each command, go to step 30). If scan tool does not indicate A/C CONTROL HEAD (DESIRED) parameter turns on and off with each command, go to step 33).

13) Using scan tool, command A/C compressor clutch relay on and off. If A/C compressor clutch relay turns on and off with each command, go to step 17). If A/C compressor clutch relay does not turn on and off with each command, go to next step.

14) Turn ignition switch to OFF position. Disconnect A/C compressor clutch relay. Turn ignition switch to ON position, with engine off. Using test light connected to ground, probe coil side voltage supply circuit of A/C compressor clutch relay. If test light is on, go to next step. If test light is off, go to step 27).

15) Connect test light between control circuit (Dark Green/White wire) of A/C compressor clutch relay and coil side voltage supply circuit of A/C compressor clutch relay. Using scan tool, command A/C compressor clutch relay on and off. If test light turns on and off with each command, go to step 29). If test light does not turn

on and off with each command, go to next step.

16) If test light remains on with each command, go to step 23). If test light does not remain on with each command, go to step 22).

17) Turn ignition switch to OFF position. Disconnect A/C compressor clutch relay. Using test light connected to ground, probe switch side voltage supply circuit of A/C compressor clutch relay. If test light is on, go to next step. If test light is off, go to step 26).

18) Connect fused jumper (10 amp) between switch side voltage circuit of A/C compressor clutch relay and A/C compressor clutch supply voltage circuit (Dark Green wire) of A/C compressor clutch. Turn ignition switch to ON position, with engine off. If A/C compressor clutch engages, go to step 29). If A/C compressor clutch does not engage, go to step 24).

19) Check ignition voltage circuit (Brown wire and Orange wire) of HVAC control module for short to ground, high resistance, or open. If problem was found, repair as necessary. After repairs, go to step 42). If problem was not found, go to step 21).

20) Check ground circuit (Black wire) of A/C pressure sensor for open. If problem was found, repair as necessary. After repairs, go to step 42). If problem was not found, go to step 28).

21) Check ground circuit (Black wire) of HVAC control module for open. If problem was found, repair as necessary. After repairs, go to step 42). If problem was not found, go to step 33).

22) Check control circuit (Dark Green/White wire) of A/C compressor clutch relay for open. If problem was found, repair as necessary. After repairs, go to step 42). If problem was not found, go to step 34).

23) Check control circuit (Dark Green/White wire) of A/C compressor clutch relay for short to ground. If problem was found, repair as necessary. After repairs, go to step 42). If problem was not found, go to step 34).

24) Check A/C compressor clutch supply voltage circuit (Dark Green wire) at A/C compressor clutch for short to ground, high resistance, or open. If problem was found, repair as necessary. After repairs, go to step 42). If problem was not found, go to next step.

25) Check ground circuit (Black wire) of A/C compressor clutch for high resistance or open. If problem was found, repair as necessary. After repairs, go to step 42). If problem was not found, go to step 32).

26) Repair switch side voltage supply circuit of A/C compressor clutch relay. After repairs, go to step 42).

27) Repair coil side voltage supply circuit of A/C compressor clutch relay. After repairs, go to step 42).

28) Check A/C high pressure sensor connector for poor connections. If problem was found, repair as necessary. After repairs, go to step 42). If problem was not found, go to step 37).

29) Check A/C compressor clutch relay connector for poor connections. If problem was found, repair as necessary. After repairs, go to step 42). If problem was not found, go to step 38).

30) Check IPM connector for poor connections. If problem was found, repair as necessary. After repairs, go to step 42). If problem was not found, go to step 35).

31) Check DIM connector for poor connections. If problem was found, repair as necessary. After repairs, go to step 42). If problem was not found, go to step 36).

32) Check A/C compressor clutch connector for poor connections. If problem was found, repair as necessary. After repairs, go to step 42). If problem was not found, go to step 39).

33) Check HVAC control module connector for poor connections. If problem was found, repair as necessary. After repairs, go to step 42). If problem was not found, go to step 40).

34) Check PCM connectors for poor connections. If problem was found, repair as necessary. After repairs, go to step 42). If problem was not found, go to step 41).

35) Replace IPM. See appropriate INSTRUMENT PANELS article in ACCESSORIES & EQUIPMENT. After repairs, go to step 42).

36) Replace DIM. See REMOVAL & INSTALLATION in appropriate BODY CONTROL MODULES article. After repairs, go to step 42).

37) Replace A/C high pressure switch. After repairs, go to step 42).

38) Replace A/C compressor clutch relay. After repairs, go to step 42).

39) Replace A/C compressor clutch coil. See appropriate COMPRESSOR SERVICING article in GENERAL SERVICING. After repairs, go to step 42).

40) Replace HVAC control module. See REMOVAL & INSTALLATION in appropriate AUTOMATIC A/C-HEATER SYSTEMS article. After repairs, go to step 42).

41) Replace PCM. See appropriate REMOVAL, OVERHAUL & INSTALLATION article in ENGINE PERFORMANCE. After repairs, go to next step.

42) Operate system to verify repair.

Compressor Clutch Does Not Engage (Manual A/C)

1) If diagnostic system check has not been performed, see DIAGNOSTIC SYSTEM CHECK (MANUAL A/C). If diagnostic system check has been performed, go to next step.

2) Ensure outside air temperature is greater than 38°F (3°C). Start engine. Turn blower motor switch to maximum speed position. Place bi-level in ON position. Place air temperature control switch in coldest position. If A/C compressor operates, problem is intermittent. If A/C compressor does not operate, go to next step.

3) Park vehicle inside or in shade. Open windows in order to ventilate interior of vehicle. If A/C system was operating, then allow A/C system to equalize for about 2 minutes. Turn ignition switch to OFF position. Install Refrigerant Station (J 43600 ACR 2000). Record outside air temperature at vehicle. Record readings of low and high side static pressures. Compare pressure values with specifications for ambient air temperature. See PRESSURE-TEMPERATURE RELATIONSHIP article in GENERAL SERVICING. If pressure values are within specification for ambient air temperature and within 15 psi (1.1 kg/cm²) of each other, go to next step. If pressure values are not within specification for ambient air temperature or within 15 psi (1.1 kg/cm²) of each other, see LEAK TESTING article in GENERAL SERVICING.

4) Turn ignition switch to ON position, with engine off. Using scan tool, observe A/C HIGH SIDE PRESSURE SENSOR parameter in POWERTRAIN data list. Compare A/C high side pressure on scan tool to high side pressure value on refrigerant station. If high side pressure values are within 15 psi (1.1 kg/cm²) of each other, go to next step. If high side pressure values are not within 15 psi (1.1 kg/cm²) of each other, go to step 24).

5) If HVAC control module is inoperative, go to step 19). If HVAC control module is not inoperative, go to next step.

6) Start engine. Using scan tool, observe COMMANDED A/C parameter in POWERTRAIN data list. Turn air temperature switch to coldest position. Place bi-level switch in ON position. If scan tool indicates COMMANDED A/C parameter is ON, go to step 13). If scan tool does not indicate COMMANDED A/C parameter is ON, go to next step.

7) Using scan tool, observe A/C CLUTCH (DESIRED) parameter in DIM A/C INFORMATION list. If scan tool indicates A/C CLUTCH (DESIRED) parameter is ON, go to next step. If scan tool does not indicate A/C CLUTCH (DESIRED) parameter is ON, go to step 9).

8) Using scan tool, observe A/C CLUTCH (ACTUAL) parameter in DIM A/C INFORMATION list. If scan tool indicates A/C CLUTCH (ACTUAL)

parameter is ON, go to step 13). If scan tool does not indicate A/C CLUTCH (ACTUAL) parameter is ON, go to step 33).

9) Using scan tool, observe CONTROL HEAD (DESIRED) parameter in DIM A/C INFORMATION list. If scan tool indicates CONTROL HEAD (DESIRED) parameter is ON, go to next step. If scan tool does not indicate CONTROL HEAD (DESIRED) parameter is ON, go to step 12).

10) Using scan tool, observe PRESSURE STATUS parameter in DIM A/C INFORMATION list. If scan tool indicates PRESSURE STATUS parameter is NORMAL, go to next step. If scan tool does not indicate PRESSURE STATUS parameter is NORMAL, problem is intermittent.

11) Using scan tool, observe TEMPERATURE STATUS parameter in DIM A/C INFORMATION list. If scan tool indicates TEMPERATURE STATUS parameter is OK, go to step 30). If scan tool does not indicate TEMPERATURE STATUS parameter is OK, check engine for overheating.

12) Using scan tool, observe A/C CONTROL HEAD (DESIRED) parameter in DIM A/C INFORMATION list. Turn mode switch to and from DEFROST position. If scan tool indicates A/C CONTROL HEAD (DESIRED) parameter turns on and off with each command, go to step 30). If scan tool does not indicate A/C CONTROL HEAD (DESIRED) parameter turns on and off with each command, go to step 32).

13) Using scan tool, command A/C compressor clutch relay on and off. If A/C compressor clutch relay turns on and off with each command, go to step 17). If A/C compressor clutch relay does not turn on and off with each command, go to next step.

14) Turn ignition switch to OFF position. Disconnect A/C compressor clutch relay. Turn ignition switch to ON position, with engine off. Using test light connected to ground, probe coil side voltage supply circuit of A/C compressor clutch relay. If test light is on, go to next step. If test light is off, go to step 27).

15) Connect test light between control circuit (Dark Green/White wire) and coil side voltage supply circuit of A/C compressor clutch relay. Using scan tool, command A/C compressor clutch relay on and off. If test light turns on and off with each command, go to step 29). If test light does not turn on and off with each command, go to next step.

16) If test light remains on with each command, go to step 22). If test light does not remain on with each command, go to step 21).

17) Turn ignition switch to OFF position. Disconnect A/C compressor clutch relay. Using test light connected to ground, probe switch side voltage supply circuit of A/C compressor clutch relay. If test light is on, go to next step. If test light is off, go to step 26).

18) Connect fused jumper (10 amp) between switch side voltage circuit and supply voltage circuit (Dark Green wire) of A/C compressor clutch relay. Turn ignition switch to ON position, with engine off. If A/C compressor clutch engages, go to step 29). If A/C compressor clutch does not engage, go to step 23).

19) Check ignition voltage circuit (Brown wire) of HVAC control assembly for short to ground, high resistance, or open. If problem was found, repair as necessary. After repairs, go to step 40). If problem was not found, go to next step.

20) Check ground circuit (Black wire) of HVAC control assembly for open. If problem was found, repair as necessary. After repairs, go to step 40). If problem was not found, go to step 32).

21) Check control circuit (Dark Green/White wire) of A/C compressor clutch relay for open. If problem was found, repair as necessary. After repairs, go to step 40). If problem was not found, go to step 33).

22) Check control circuit (Dark Green/White wire) of A/C compressor clutch relay for short to ground. If problem was found, repair as necessary. After repairs, go to step 40). If problem was not found, go to step 33).

23) Check supply voltage circuit (Dark Green wire) at A/C compressor clutch for short to ground, high resistance, or open. If problem was found, repair as necessary. After repairs, go to step 40). If problem was not found, go to step 25).

24) Check ground circuit (Black wire) of A/C pressure sensor for open. If problem was found, repair as necessary. After repairs, go to step 40). If problem was not found, go to step 28).

25) Check ground circuit (Black wire) of A/C compressor clutch for high resistance or open. If problem was found, repair as necessary. After repairs, go to step 40). If problem was not found, go to step 31).

26) Repair switch side voltage supply circuit of A/C compressor clutch relay. After repairs, go to step 40).

27) Repair coil side voltage supply circuit of A/C compressor clutch relay. After repairs, go to step 40).

28) Check A/C high pressure sensor connector for poor connections. If problem was found, repair as necessary. After repairs, go to step 40). If problem was not found, go to step 35).

29) Check A/C compressor clutch relay connector for poor connections. If problem was found, repair as necessary. After repairs, go to step 40). If problem was not found, go to step 36).

30) Check DIM connector for poor connections. If problem was found, repair as necessary. After repairs, go to step 40). If problem was not found, go to step 34).

31) Check A/C compressor clutch connector for poor connections. If problem was found, repair as necessary. After repairs, go to step 40). If problem was not found, go to step 37).

32) Check HVAC control module connector for poor connections. If problem was found, repair as necessary. After repairs, go to step 40). If problem was not found, go to step 38).

33) Check PCM connectors for poor connections. If problem was found, repair as necessary. After repairs, go to step 40). If problem was not found, go to step 39).

34) Replace DIM. See REMOVAL & INSTALLATION in appropriate BODY CONTROL MODULES article. After repairs, go to step 40).

35) Replace A/C high pressure switch. After repairs, go to step 40).

36) Replace A/C compressor clutch relay. After repairs, go to step 40).

37) Replace A/C compressor clutch coil. See appropriate COMPRESSOR SERVICING article in GENERAL SERVICING. After repairs, go to step 40).

38) Replace HVAC control module. See REMOVAL & INSTALLATION in appropriate MANUAL A/C-HEATER SYSTEMS article. After repairs, go to step 40).

39) Replace PCM. See appropriate REMOVAL, OVERHAUL & INSTALLATION article in ENGINE PERFORMANCE. After repairs, go to next step.

40) Operate system to verify repair.

Compressor Clutch Does Not Disengage (Automatic A/C)

1) If diagnostic system check has not been performed, see DIAGNOSTIC SYSTEM CHECK (AUTOMATIC A/C). If diagnostic system check has been performed, go to next step.

2) Start engine. Turn blower motor switch to OFF position. Place A/C switch in OFF position. If A/C compressor operates, go to next step. If A/C compressor clutch does not operate, problem is intermittent.

3) Using scan tool, observe A/C RELAY COMMANDED parameter in PCM data list. If scan tool indicates A/C RELAY COMMANDED parameter is ON, go to next step. If scan tool does not indicate A/C RELAY COMMANDED parameter is ON, go to step 7).

4) Using scan tool, observe A/C CONTROL HEAD (DESIRED)

parameter in DIM A/C INFORMATION list. If scan tool displays OFF, go to next step. If scan tool does not display OFF, go to step 12).

5) Using scan tool, observe A/C REQUESTED parameter in IPM HVAC SYSTEM data list. If scan tool displays YES, go to next step. If scan tool does not display YES, go to step 13).

6) Using scan tool, observe A/C CLUTCH (DESIRED) parameter in DIM A/C INFORMATION list. If scan tool displays OFF, go to step 15). If scan tool does not display OFF, go to step 14).

7) Turn ignition switch to OFF position. Disconnect A/C compressor clutch relay. Turn ignition switch to ON position. If A/C compressor clutch disengages, go to next step. If A/C compressor clutch does not disengage, go to step 9).

8) Check control circuit (Dark Green/White wire) of A/C compressor clutch relay for short to ground. If problem was found, repair as necessary. After repairs, go to step 22). If problem was not found, go to step 11).

9) Check A/C compressor clutch voltage supply circuit (Dark Green wire) for short to voltage. If problem was found, repair as necessary. After repairs, go to step 22). If problem was not found, go to next step.

10) Check A/C compressor clutch connector for poor connections. If problem was found, repair as necessary. After repairs, go to step 22). If problem was not found, go to step 17).

11) Check A/C compressor clutch relay connector for poor connections. If problem was found, repair as necessary. After repairs, go to step 22). If problem was not found, go to step 16).

12) Check HVAC control module connector for poor connections. If problem was found, repair as necessary. After repairs, go to step 22). If problem was not found, go to step 18).

13) Check IPM connector for poor connections. If problem was found, repair as necessary. After repairs, go to step 22). If problem was not found, go to step 19).

14) Check DIM connector for poor connections. If problem was found, repair as necessary. After repairs, go to step 22). If problem was not found, go to step 20).

15) Check PCM connectors for poor connections. If problem was found, repair as necessary. After repairs, go to step 22). If problem was not found, go to step 21).

16) Replace A/C compressor clutch relay. After repairs, go to step 22).

17) Replace A/C compressor clutch hub and plate. See appropriate COMPRESSOR SERVICING article in GENERAL SERVICING. After repairs, go to step 22).

18) Replace HVAC control module. See REMOVAL & INSTALLATION in appropriate AUTOMATIC A/C-HEATER SYSTEMS article. After repairs, go to step 22).

19) Replace IPM. See appropriate INSTRUMENT PANELS article in ACCESSORIES & EQUIPMENT. After repairs, go to step 22).

20) Replace DIM. See REMOVAL & INSTALLATION in appropriate BODY CONTROL MODULES article. After repairs, go to step 22).

21) Replace PCM. See appropriate REMOVAL, OVERHAUL & INSTALLATION article in ENGINE PERFORMANCE. After repairs, go to next step.

22) Operate system to verify repair.

Compressor Clutch Does Not Disengage (Manual A/C)

1) If diagnostic system check has not been performed, see DIAGNOSTIC SYSTEM CHECK (MANUAL A/C). If diagnostic system check has been performed, go to next step.

2) Start engine. Turn blower motor switch to OFF position. Place bi-level switch in OFF position. If A/C compressor operates, go to next step. If A/C compressor clutch does not operate, problem is intermittent.

3) Using scan tool, observe COMMANDED A/C parameter in POWERTRAIN data list. If scan tool indicates COMMANDED A/C parameter is ON, go to next step. If scan tool does not indicate COMMANDED A/C parameter is ON, go to step 6).

4) Using scan tool, observe A/C CONTROL HEAD (DESIRED) parameter in DIM A/C INFORMATION list. If scan tool displays OFF, go to next step. If scan tool does not display OFF, go to step 11).

5) Using scan tool, observe A/C CLUTCH (DESIRED) parameter in DIM A/C INFORMATION List. If scan tool displays OFF, go to step 13). If scan tool does not display OFF, go to step 12).

6) Turn ignition switch to OFF position. Disconnect A/C compressor clutch relay. Turn ignition switch to ON position. If A/C compressor clutch disengages, go to next step. If A/C compressor clutch does not disengage, go to step 8).

7) Check control circuit (Dark Green/White wire) of A/C compressor clutch relay for short to ground. If problem was found, repair as necessary. After repairs, go to step 19). If problem was not found, go to step 10).

8) Check A/C compressor clutch voltage supply circuit (Dark Green wire) for short to voltage. If problem was found, repair as necessary. After repairs, go to step 19). If problem was not found, go to next step.

9) Check A/C compressor clutch connector for poor connections. If problem was found, repair as necessary. After repairs, go to step 19). If problem was not found, go to step 15).

10) Check A/C compressor clutch relay connector for poor connections. If problem was found, repair as necessary. After repairs, go to step 19). If problem was not found, go to step 14).

11) Check HVAC control module connector for poor connections. If problem was found, repair as necessary. After repairs, go to step 19). If problem was not found, go to step 16).

12) Check DIM connector for poor connections. If problem was found, repair as necessary. After repairs, go to step 19). If problem was not found, go to step 17).

13) Check PCM connectors for poor connections. If problem was found, repair as necessary. After repairs, go to step 19). If problem was not found, go to step 18).

14) Replace A/C compressor clutch relay. After repairs, go to step 19).

15) Replace A/C compressor clutch hub and plate. See appropriate COMPRESSOR SERVICING article in GENERAL SERVICING. After repairs, go to step 19).

16) Replace HVAC control module. See REMOVAL & INSTALLATION in appropriate MANUAL A/C-HEATER SYSTEMS article. After repairs, go to step 19).

17) Replace DIM. See REMOVAL & INSTALLATION in appropriate BODY CONTROL MODULES article. After repairs, go to step 19).

18) Replace PCM. See appropriate REMOVAL, OVERHAUL & INSTALLATION article in ENGINE PERFORMANCE. After repairs, go to next step.

19) Operate system to verify repair.

3.8L: PARK AVENUE

NOTE: For circuit, wire color and terminal identification, see WIRING DIAGRAMS. Also see WIRING DIAGRAMS in appropriate MANUAL or AUTOMATIC A/C HEATER SYSTEMS article.

Description

Compressor for air conditioning system is belt-driven by engine through A/C compressor clutch. Clutch controls compressor in the following ways:

- * Disengages when air conditioning is not requested.
- * Disengages when engine load must be reduced.

Heater and A/C control automatically requests A/C compressor clutch engagement with system operating in defrost mode.

Under normal operating conditions, the following events occur:

- * A/C-heater control sends an A/C operation desired message to Body Control Module (BCM). BCM sends a request for A/C compressor clutch engagement to Powertrain Control Module (PCM).
- * PCM supplies a ground to A/C compressor control relay coil.
- * A/C CLU relay energizes.
- * Voltage is supplied to A/C compressor clutch through A/C CLU fuse.
- * A/C compressor clutch engages and compressor runs.

PCM monitors A/C refrigerant line pressure and engine coolant temperature. This information is placed on Class 2 communication link and is monitored by DIM. DIM looks at A/C line pressure, engine coolant temperature and battery voltage. DIM will request A/C operation from PCM if these parameters are within normal operation limits and A/C-heater control is requesting A/C operation.

If PCM determines that engine load should be reduced, such as during full throttle conditions, PCM will de-energize A/C compressor control relay. This will disengage compressor, even though request for A/C compressor clutch engagement from A/C-heater control is still present.

A/C compressor clutch diode is connected across A/C compressor clutch terminals. This diode provides a path for current resulting from voltage spikes. Collapsing magnetic field of A/C compressor clutch coil generate these voltage spikes. Voltage spikes occur every time coil is de-energized.

Diagnostic System Check

1) Install scan tool. If scan tool powers up, go to next step. If scan tool does not power up, see SCAN TOOL DOES NOT POWER UP in appropriate BODY CONTROL MODULES article.

2) Turn ignition on, engine off. Try to establish scan tool communication with A/C-heater control module, Body Control Module (BCM) and Powertrain Control Module (PCM). If communication with all modules is established, go to next step. If communication with all modules is not established, see SCAN TOOL DOES NOT COMMUNICATE WITH CLASS 2 DEVICE in appropriate BODY CONTROL MODULES article.

3) Select display DTC function for each module. Record all displayed DTCs, status of displayed DTCs and which module set DTCs. If DTCs are displayed, go to next step. If no DTCs are displayed, see COMPRESSOR CLUTCH DOES NOT ENGAGE or COMPRESSOR CLUTCH DOES NOT DISENGAGE.

4) If scan tool displays DTCs beginning with "B", see appropriate SELF-DIAGNOSTICS article in BODY CONTROL MODULES. If scan tool displays DTCs beginning with "P", see appropriate SELF-DIAGNOSTICS article in ENGINE PERFORMANCE. If scan tool displays DTCs beginning with "U", see SCAN TOOL DOES NOT COMMUNICATE WITH CLASS 2 DEVICE in appropriate BODY CONTROL MODULES article.

Compressor Clutch Does Not Engage

1) If diagnostic system check has not been performed, see DIAGNOSTIC SYSTEM CHECK. If diagnostic system check has been

performed, go to next step.

2) Ensure outside air temperature is greater than 38°F (3°C). Start engine. Turn blower motor switch to maximum speed position. Place mode switch in DEFROST position. Place air temperature control switch in coldest position. If A/C compressor operates, problem is intermittent. If A/C compressor does not operate, go to next step.

3) Park vehicle inside or in shade. Open windows in order to ventilate interior of vehicle. If A/C system was operating, then allow A/C system to equalize for about 2 minutes. Turn ignition switch to OFF position. Install Refrigerant Station (J 43600 ACR 2000). Record outside air temperature at vehicle. Record readings of low and high side static pressures. Compare pressure values with specifications for ambient air temperature. See PRESSURE-TEMPERATURE RELATIONSHIP article in GENERAL SERVICING. If pressure values are within specification for ambient air temperature and within 15 psi (1.1 kg/cm²) of each other, go to next step. If pressure values are not within specification for ambient air temperature or within 15 psi (1.1 kg/cm²) of each other, see LEAK TESTING article in GENERAL SERVICING.

4) Turn ignition switch to ON position, with engine off. Using scan tool, observe A/C HIGH SIDE PRESSURE SENSOR parameter in POWERTRAIN data list. Compare A/C HIGH SIDE PRESSURE on scan tool to high side pressure value on refrigerant station. If high side pressure values are within 15 psi (1.1 kg/cm²) of each other, go to next step. If high side pressure values are not within 15 psi (1.1 kg/cm²) of each other, go to step 23).

5) If HVAC control module is inoperative, go to step 19). If HVAC control module is not inoperative, go to next step.

6) Start engine. Using scan tool, observe COMMANDED A/C parameter in POWERTRAIN data list. Turn air temperature switch to coldest position. If scan tool indicates COMMANDED A/C parameter is ON, go to step 13). If scan tool does not indicate COMMANDED A/C parameter is ON, go to next step.

7) Using scan tool, observe A/C CLUTCH (DESIRED) parameter in BCM A/C INFORMATION list. If scan tool indicates A/C CLUTCH (DESIRED) parameter is ON, go to next step. If scan tool does not indicate A/C CLUTCH (DESIRED) parameter is ON, go to step 9).

8) Using scan tool, observe A/C CLUTCH (ACTUAL) parameter in BCM A/C INFORMATION list. If scan tool indicates A/C CLUTCH (ACTUAL) parameter is ON, go to step 13). If scan tool does not indicate A/C CLUTCH (ACTUAL) parameter is ON, go to step 34).

9) Using scan tool, observe CONTROL HEAD (DESIRED) parameter in BCM A/C INFORMATION list. If scan tool indicates CONTROL HEAD (DESIRED) parameter is ON, go to next step. If scan tool does not indicate CONTROL HEAD (DESIRED) parameter is ON, go to step 12).

10) Using scan tool, observe PRESSURE STATUS parameter in BCM A/C INFORMATION list. If scan tool indicates PRESSURE STATUS parameter is NORMAL, go to next step. If scan tool does not indicate PRESSURE STATUS parameter is NORMAL, problem is intermittent.

11) Using scan tool, observe TEMPERATURE STATUS parameter in BCM A/C INFORMATION list. If scan tool indicates TEMPERATURE STATUS parameter is okay, go to step 31). If scan tool does not indicate TEMPERATURE STATUS parameter is okay, check engine for overheating.

12) Using scan tool, observe A/C REQUESTED parameter in HVAC SYSTEM data list. Turn mode switch to and from DEFROST position. If scan tool indicates A/C REQUESTED parameter turns on and off with each command, go to step 30). If scan tool does not indicate A/C REQUESTED parameter turns on and off with each command, go to step 33).

13) Using scan tool, command A/C compressor clutch relay on and off. If A/C compressor clutch relay turns on and off with each command, go to step 17). If A/C compressor clutch relay does not turn on and off with each command, go to next step.

14) Turn ignition switch to OFF position. Disconnect A/C compressor clutch relay. Turn ignition switch to ON position, with

engine off. Using test light connected to ground, probe coil side voltage supply circuit of A/C compressor clutch relay. If test light is on, go to next step. If test light is off, go to step 27).

15) Connect test light between control circuit (Dark Green/White wire) of A/C compressor clutch relay and coil side voltage supply circuit of A/C compressor clutch relay. Using scan tool, command A/C compressor clutch relay on and off. If test light turns on and off with each command, go to step 29). If test light does not turn on and off with each command, go to next step.

16) If test light remains on with each command, go to step 21). If test light does not remain on with each command, go to step 20).

17) Turn ignition switch to OFF position. Disconnect A/C compressor clutch relay. Using test light connected to ground, probe switch side voltage supply circuit of A/C compressor clutch relay. If test light is on, go to next step. If test light is off, go to step 26).

18) Connect fused jumper (10 amp) between switch side voltage circuit of A/C compressor clutch relay and A/C compressor clutch supply voltage circuit (Dark Green wire) of A/C compressor clutch. Turn ignition switch to ON position, with engine off. If A/C compressor clutch engages, go to step 29). If A/C compressor clutch does not engage, go to step 22).

19) Check ignition voltage circuit (Brown wire) of HVAC control module for short to ground, high resistance, or open. If problem was found, repair as necessary. After repairs, go to step 42). If problem was not found, go to next step.

20) Check ground circuit (Black/White wire) of HVAC control module for open. If problem was found, repair as necessary. After repairs, go to step 42). If problem was not found, go to step 33).

21) Check control circuit (Dark Green/White wire) of A/C compressor clutch relay for open. If problem was found, repair as necessary. After repairs, go to step 42). If problem was not found, go to step 34).

22) Check control circuit (Dark Green/White wire) of A/C compressor clutch relay for short to ground. If problem was found, repair as necessary. After repairs, go to step 42). If problem was not found, go to step 34).

23) Check A/C compressor clutch supply voltage circuit (Dark Green wire) at A/C compressor clutch for short to ground, high resistance, or open. If problem was found, repair as necessary. After repairs, go to step 42). If problem was not found, go to step 25).

24) Check ground circuit (Black wire) of A/C pressure sensor for open. If problem was found, repair as necessary. After repairs, go to step 42). If problem was not found, go to step 28).

25) Check ground circuit (Black wire) of A/C compressor clutch for high resistance or open. If problem was found, repair as necessary. After repairs, go to step 42). If problem was not found, go to step 32).

26) Repair switch side voltage supply circuit of A/C compressor clutch relay. After repairs, go to step 42).

27) Repair coil side voltage supply circuit of A/C compressor clutch relay. After repairs, go to step 42).

28) Check A/C high pressure sensor connector for poor connections. If problem was found, repair as necessary. After repairs, go to step 42). If problem was not found, go to step 36).

29) Check A/C compressor clutch relay connector for poor connections. If problem was found, repair as necessary. After repairs, go to step 42). If problem was not found, go to step 38).

30) Check IPM connector for poor connections. If problem was found, repair as necessary. After repairs, go to step 42). If problem was not found, go to step 35).

31) Check BCM connectors for poor connections. If problem was

found, repair as necessary. After repairs, go to step 42). If problem was not found, go to step 37).

32) Check A/C compressor clutch connector for poor connections. If problem was found, repair as necessary. After repairs, go to step 42). If problem was not found, go to step 39).

33) Check HVAC control module connector for poor connections. If problem was found, repair as necessary. After repairs, go to step 42). If problem was not found, go to step 40).

34) Check PCM connectors for poor connections. If problem was found, repair as necessary. After repairs, go to step 42). If problem was not found, go to step 41).

35) Replace IPM. See appropriate INSTRUMENT PANELS article in ACCESSORIES & EQUIPMENT. After repairs, go to step 42).

36) Replace A/C high pressure switch. After repairs, go to step 42).

37) Replace BCM. See REMOVAL & INSTALLATION in appropriate BODY CONTROL MODULES article. After repairs, go to step 42).

38) Replace A/C compressor clutch relay. After repairs, go to step 42).

39) Replace A/C compressor clutch coil. See appropriate COMPRESSOR SERVICING article in GENERAL SERVICING. After repairs, go to step 42).

40) Replace HVAC control module. See REMOVAL & INSTALLATION in appropriate AUTOMATIC A/C-HEATER SYSTEMS article. After repairs, go to step 42).

41) Replace PCM. See appropriate REMOVAL, OVERHAUL & INSTALLATION article in ENGINE PERFORMANCE. After repairs, go to next step.

42) Operate system to verify repair.

Compressor Clutch Does Not Disengage

1) If diagnostic system check has not been performed, see DIAGNOSTIC SYSTEM CHECK. If diagnostic system check has been performed, go to next step.

2) Start engine. Turn blower motor switch to OFF position. Place A/C switch in OFF position. If A/C compressor operates, go to next step. If A/C compressor clutch does not operate, problem is intermittent.

3) Using scan tool, observe COMMANDED A/C parameter in PCM data list. If scan tool indicates COMMANDED A/C parameter is ON, go to next step. If scan tool does not indicate COMMANDED A/C parameter is ON, go to step 7).

4) Using scan tool, observe A/C CONTROL HEAD (DESIRED) parameter in BCM A/C INFORMATION list. If scan tool displays OFF, go to next step. If scan tool does not display OFF, go to step 12).

5) Using scan tool, observe A/C REQUESTED parameter in IPM HVAC SYSTEM data list. If scan tool displays NO, go to next step. If scan tool does not display NO, go to step 13).

6) Using scan tool, observe A/C CLUTCH (DESIRED) parameter in BCM A/C INFORMATION list. If scan tool displays OFF, go to step 15). If scan tool does not display OFF, go to step 14).

7) Turn ignition switch to OFF position. Disconnect A/C compressor clutch relay. Turn ignition switch to ON position, with engine off. If A/C compressor clutch disengages, go to next step. If A/C compressor clutch does not disengage, go to step 9).

8) Check control circuit (Dark Green/White wire) of A/C compressor clutch relay for short to ground. If problem was found, repair as necessary. After repairs, go to step 22). If problem was not found, go to step 11).

9) Check A/C compressor clutch voltage supply circuit (Dark Green wire) for short to voltage. If problem was found, repair as necessary. After repairs, go to step 22). If problem was not found, go to next step.

- 10) Check A/C compressor clutch connector for poor connections. If problem was found, repair as necessary. After repairs, go to step 22). If problem was not found, go to step 17).
- 11) Check A/C compressor clutch relay connector for poor connections. If problem was found, repair as necessary. After repairs, go to step 22). If problem was not found, go to step 16).
- 12) Check HVAC connector for poor connections. If problem was found, repair as necessary. After repairs, go to step 22). If problem was not found, go to step 18).
- 13) Check IPM connector for poor connections. If problem was found, repair as necessary. After repairs, go to step 22). If problem was not found, go to step 19).
- 14) Check BCM connector for poor connections. If problem was found, repair as necessary. After repairs, go to step 22). If problem was not found, go to step 20).
- 15) Check PCM connectors for poor connections. If problem was found, repair as necessary. After repairs, go to step 22). If problem was not found, go to step 21).
- 16) Replace A/C compressor clutch relay. After repairs, go to step 22).
- 17) Replace A/C compressor clutch hub and plate. See appropriate COMPRESSOR SERVICING article in GENERAL SERVICING. After repairs, go to step 22).
- 18) Replace HVAC control module. See REMOVAL & INSTALLATION in appropriate AUTOMATIC A/C-HEATER SYSTEMS article. After repairs, go to step 22).
- 19) Replace IPM. See appropriate INSTRUMENT PANELS article in ACCESSORIES & EQUIPMENT. After repairs, go to step 22).
- 20) Replace BCM. See REMOVAL & INSTALLATION in appropriate BODY CONTROL MODULES article. After repairs, go to step 22).
- 21) Replace PCM. See appropriate REMOVAL, OVERHAUL & INSTALLATION article in ENGINE PERFORMANCE. After repairs, go to next step.
- 22) Operate system to verify repair.

3.8L & 5.7L: CAMARO & FIREBIRD

NOTE: For circuit, wire color and terminal identification, see WIRING DIAGRAMS. Also see WIRING DIAGRAMS in appropriate MANUAL or AUTOMATIC A/C HEATER SYSTEMS article.

Description

A/C system can operate regardless of temperature setting, as long as ambient air temperature is greater than 38°F (3°C). If A/C compressor clutch is turned off due to cold ambient air temperatures, compressor will not come back on until ambient air temperatures reach 41°F (5°C).

Regardless of selected A/C mode setting, a request is made to Powertrain Control Module (PCM) to turn on A/C compressor clutch. Request is made through A/C request signal circuit from HVAC control assembly. Power and ground are provided to HVAC control assembly by ignition voltage and ground circuits.

When vehicle operator makes an A/C request, a 12 volt request signal is sent out over A/C request signal circuit and grounded through PCM. When this request signal is grounded, PCM can activate A/C compressor clutch.

PCM turns on A/C compressor clutch by providing a path to ground through A/C compressor clutch relay control circuit for A/C compressor clutch relay. Power is provided to A/C compressor clutch relay from of underhood fuse block on ignition voltage circuit. Once

relay closes its internal switch, power from battery is provided to A/C compressor clutch through A/C compressor clutch supply voltage circuit. Whenever compressor is turned off, A/C compressor clutch diode prevents a voltage spike from entering vehicles electrical system. Ground circuit provides a path to ground for compressor. A/C compressor clutch relay control circuit is grounded internally within PCM. On vehicles with V8 option, an A/C compressor clutch status signal is sent to PCM on A/C compressor clutch supply voltage circuit.

Diagnostic System Check

- 1) Install scan tool. If scan tool powers up, go to next step. If scan tool does not power up, see SCAN TOOL DOES NOT POWER UP in appropriate BODY CONTROL MODULES article.
- 2) Turn ignition on, engine off. Try to establish scan tool communication with Powertrain Control Module (PCM). If communication with PCM is established, go to next step. If communication with PCM is not established, see SCAN TOOL DOES NOT COMMUNICATE WITH CLASS 2 DEVICE in appropriate BODY CONTROL MODULES article.
- 3) Select display DTC function for PCM. Record all displayed DTCs and status of displayed DTCs. If DTCs are displayed, go to next step. If no DTCs are displayed, see COMPRESSOR CLUTCH DOES NOT ENGAGE or COMPRESSOR CLUTCH DOES NOT DISENGAGE.
- 4) If scan tool does not display DTCs beginning with "U", see appropriate SELF-DIAGNOSTICS article in ENGINE PERFORMANCE. If scan tool displays DTCs beginning with "U", see SCAN TOOL DOES NOT COMMUNICATE WITH CLASS 2 DEVICE in appropriate BODY CONTROL MODULES article.

Compressor Clutch Does Not Engage

- 1) If diagnostic system check has not been performed, see DIAGNOSTIC SYSTEM CHECK. If diagnostic system check has been performed, go to next step.
- 2) Ensure outside air temperature is greater than 38°F (3°C). Start engine. Turn blower motor switch to maximum speed position. Place A/C request switch in ON position. Place air temperature control switch in coldest position. If A/C compressor operates, problem is intermittent. If A/C compressor does not operate, go to next step.
- 3) Park vehicle inside or in shade. Open windows in order to ventilate interior of vehicle. If A/C system was operating, then allow A/C system to equalize for about 2 minutes. Turn ignition switch to OFF position. Install Refrigerant Station (J 43600 ACR 2000). Record outside air temperature at vehicle. Record readings of low and high side static pressures. Compare pressure values with specifications for ambient air temperature. See PRESSURE-TEMPERATURE RELATIONSHIP article in GENERAL SERVICING. If pressure values are within specification for ambient air temperature and within 15 psi (1.1 kg/cm²) of each other, go to next step. If pressure values are not within specification for ambient air temperature or within 15 psi (1.1 kg/cm²) of each other, see LEAK TESTING article in GENERAL SERVICING.
- 4) Turn ignition switch to ON position, with engine off. Using scan tool, observe A/C HIGH SIDE PRESSURE SENSOR parameter in POWERTRAIN data list. Compare A/C HIGH SIDE PRESSURE on scan tool to high side pressure value on refrigerant station. If high side pressure values are within 15 psi (1.1 kg/cm²) of each other, go to next step. If high side pressure values are not within 15 psi (1.1 kg/cm²) of each other, go to step 16).
- 5) If HVAC control module is inoperative, go to step 15). If HVAC control module is not inoperative, go to next step.
- 6) Start engine. Using scan tool, observe A/C REQUEST parameter in POWERTRAIN data list. Turn air temperature switch to coldest position. Turn blower motor to ON position. Place A/C request switch in ON position. If scan tool indicates A/C request parameter is YES, go to step 9). If scan tool does not indicate A/C parameter is

YES, go to next step.

7) If A/C request indicator is on, go to next step. If A/C request indicator is off, go to step 27).

8) Turn ignition switch to OFF position. Check A/C request signal circuit (Dark Green/White wire) for short to ground, high resistance, or open. If problem was found, repair as necessary. After repairs, go to step 34). If problem was not found, go to step 28).

9) Using scan tool, command A/C compressor clutch relay on and off. If A/C compressor clutch relay turns on and off with each command, go to step 13). If A/C compressor clutch relay does not turn on and off with each command, go to next step.

10) Turn ignition switch to OFF position. Disconnect A/C compressor clutch relay. Turn ignition switch to ON position, with engine off. Using test light connected to ground, probe coil side voltage supply circuit (Pink wire) of A/C compressor clutch relay. If test light is on, go to next step. If test light is off, go to step 22).

11) Connect test light between control circuit (Dark Green/White wire) of A/C compressor clutch relay and coil side voltage supply circuit (Pink wire) of A/C compressor clutch relay. Using scan tool, command A/C compressor clutch relay on and off. If test light turns on and off with each command, go to step 23). If test light does not turn on and off with each command, go to next step.

12) If test light remains on with each command, go to step 19). If test light does not remain on with each command, go to step 18).

13) Turn ignition switch to OFF position. Disconnect A/C compressor clutch relay. Using test light connected to ground, probe switch side voltage supply circuit (Pink wire) of A/C compressor clutch relay. If test light is on, go to next step. If test light is off, go to step 23).

14) Connect fused jumper (10 amp) between switch side voltage circuit (Pink wire) of A/C compressor clutch relay and A/C compressor clutch supply voltage circuit (Dark Green wire) of A/C compressor clutch. Turn ignition switch to ON position, with engine off. If A/C compressor clutch engages, go to step 25). If A/C compressor clutch does not engage, go to step 20).

15) Check voltage supply circuit (Brown wire) to HVAC control assembly for short to ground, high resistance, or open. If problem was found, repair as necessary. After repairs, go to step 34). If problem was not found, go to step 17).

16) Check ground circuit (Gray wire for 3.8L and Purple wire for 5.7L) of A/C pressure sensor for open. If problem was found, repair as necessary. After repairs, go to step 34). If problem was not found, go to step 24).

17) Check ground circuit of HVAC control assembly for open. If problem was found, repair as necessary. After repairs, go to step 34). If problem was not found, go to step 27).

18) Check control circuit (Dark Green/White wire) of A/C compressor clutch relay for open. If problem was found, repair as necessary. After repairs, go to step 34). If problem was not found, go to step 28).

19) Check control circuit (Dark Green/White wire) of A/C compressor clutch relay for short to ground. If problem was found, repair as necessary. After repairs, go to step 34). If problem was not found, go to step 28).

20) Check A/C compressor clutch supply voltage circuit (Dark Green wire) at A/C compressor clutch for short to ground, high resistance, or open. If problem was found, repair as necessary. After repairs, go to step 34). If problem was not found, go to next step.

21) Check ground circuit (Black wire) of A/C compressor clutch for high resistance or open. If problem was found, repair as necessary. After repairs, go to step 34). If problem was not found, go

to step 26).

22) Repair switch side voltage supply circuit (Pink wire) of A/C compressor clutch relay. After repairs, go to step 34).

23) Repair coil side voltage supply circuit (Pink wire) of A/C compressor clutch relay. After repairs, go to step 34).

24) Check A/C high pressure sensor connector for poor connections. If problem was found, repair as necessary. After repairs, go to step 34). If problem was not found, go to step 29).

25) Check A/C compressor clutch relay connector for poor connections. If problem was found, repair as necessary. After repairs, go to step 34). If problem was not found, go to step 30).

26) Check A/C compressor clutch connector for poor connections. If problem was found, repair as necessary. After repairs, go to step 34). If problem was not found, go to step 31).

27) Check HVAC control assembly connector for poor connections. If problem was found, repair as necessary. After repairs, go to step 34). If problem was not found, go to step 32).

28) Check PCM connectors for poor connections. If problem was found, repair as necessary. After repairs, go to step 34). If problem was not found, go to step 33).

29) Replace A/C high pressure switch. After repairs, go to step 34).

30) Replace A/C compressor clutch relay. After repairs, go to step 34).

31) Replace A/C compressor clutch coil. See appropriate COMPRESSOR SERVICING article in GENERAL SERVICING. After repairs, go to step 34).

32) Replace HVAC control assembly. See REMOVAL & INSTALLATION in appropriate MANUAL A/C-HEATER SYSTEMS article. After repairs, go to step 34).

33) Replace PCM. See appropriate REMOVAL, OVERHAUL & INSTALLATION article in ENGINE PERFORMANCE. After repairs, go to next step.

34) Operate system to verify repair.

Compressor Clutch Does Not Disengage

1) If diagnostic system check has not been performed, see DIAGNOSTIC SYSTEM CHECK. If diagnostic system check has been performed, go to next step.

2) Start engine. Turn blower motor switch to OFF position. Place A/C request switch in OFF position. If A/C compressor operates, go to next step. If A/C compressor does not operate, problem is intermittent.

3) Using scan tool, observe A/C REQUEST parameter in POWERTRAIN data list. If scan tool indicates A/C REQUEST parameter is YES, go to next step. If scan tool does not indicate A/C REQUEST parameter is YES, go to step 6).

4) Check A/C request signal circuit (Dark Green/White wire) for short to voltage. If problem was found, repair as necessary. After repairs, go to step 17). If problem was not found, go to next step.

5) Turn ignition switch to OFF position. Disconnect HVAC control connector. Back out terminal for A/C request circuit (Dark Green/White wire) from HVAC control assembly connector. Reconnect HVAC control assembly connector. Start engine. Using scan tool, observe A/C REQUEST parameter. If scan tool indicates A/C REQUEST parameter is YES, go to step 12). If scan tool does not indicate A/C REQUEST parameter is YES, go to step 11).

6) Turn ignition switch to OFF position. Remove A/C compressor clutch relay. Turn ignition switch to ON position. If A/C compressor clutch turns off, go to next step. If A/C compressor clutch does not turn off, go to step 9).

7) Measure resistance between switch side A/C compressor clutch relay terminals. If resistance is infinite, go to next step. If

resistance is not infinite, go to step 10).

8) Check A/C clutch relay control circuit (Dark Green/White wire) for short to ground. If problem was found, repair as necessary. After repairs, go to step 17). If problem was not found, go to step 12).

9) Check A/C compressor clutch supply voltage circuit (Dark Green wire) for short to voltage. If problem was found, repair as necessary. After repairs, go to step 17). If problem was not found, go to step 14).

10) Check A/C compressor clutch relay connector for poor connections. If problem was found, repair as necessary. After repairs, go to step 17). If problem was not found, go to step 13).

11) Check HVAC control assembly connector for poor connections. If problem was found, repair as necessary. After repairs, go to step 17). If problem was not found, go to step 15).

12) Check PCM connectors for poor connections. If problem was found, repair as necessary. After repairs, go to step 17). If problem was not found, go to step 16).

13) Replace A/C compressor clutch relay. After repairs, go to step 17).

14) Replace A/C compressor clutch hub and plate assembly. See appropriate COMPRESSOR SERVICING article in GENERAL SERVICING. After repairs, go to step 17).

15) Replace HVAC control assembly. See REMOVAL & INSTALLATION in appropriate MANUAL A/C-HEATER SYSTEMS article. After repairs, go to step 17).

16) Replace PCM. See appropriate REMOVAL, OVERHAUL & INSTALLATION article in ENGINE PERFORMANCE. After repairs, go to next step.

17) Operate system to verify repair.

Diagnostic Aids

Check for poor harness connections at PCM and A/C control head. Inspect for corrosion, backed-out terminal pins, and broken wires inside insulation. Check for damaged wire harness. If harness and connections are okay, disconnect PCM harness connectors. Connect a DVOM between ground and A/C clutch relay control circuit at PCM harness connector. Turn ignition switch to ON position. Observe DVOM while wiggling harness and connectors. A change in voltage indicates location of fault.

An A/C refrigerant pressure less than 35 psi (2.5 kg/cm²), or greater than 414 psi (29.1 kg/cm²) will cause PCM to disable A/C compressor clutch. With engine running and A/C on, use scan tool to monitor A/C high-side system pressure for 2 minutes. If pressure goes out of range, diagnose A/C-heater system. See MANUAL A/C-HEATER SYSTEMS - CAMARO & FIREBIRD article.

4.6L: DEVILLE & SEVILLE

NOTE: For circuit, wire color and terminal identification, see WIRING DIAGRAMS. Also see WIRING DIAGRAMS in appropriate MANUAL or AUTOMATIC A/C HEATER SYSTEMS article.

NOTE: Since many DTCs cause PCM to disable A/C compressor clutch operation, any DTCs stored in memory must be repaired and cleared before proceeding. See appropriate SELF-DIAGNOSTICS article in ENGINE PERFORMANCE.

Description

When A/C request is selected, a signal is sent from Instrument Panel Module (IPM) to Powertrain Control Module (PCM). In order for PCM to internally ground A/C clutch relay control circuit,

Dash Integration Module (DIM) and PCM must communicate with each other over class 2 serial data circuits. PCM monitors A/C refrigerant line pressure and engine coolant temperature. This information is placed on class 2 serial data circuit and is monitored by DIM. DIM looks at A/C line pressure, A/C refrigerant low temperature sensor, engine coolant temperature, battery voltage along with A/C request input from HVAC control module. DIM will request A/C operation from PCM if these parameters are within normal operating limits and IPM is requesting A/C operation. If there is a malfunction in A/C system, instrument panel will read SERVICE A/C SYSTEM to alert vehicle operator that there is a malfunction with A/C system.

PCM turns on A/C compressor by providing a path to ground through A/C clutch relay control circuit for A/C compressor clutch relay. Power is provided to A/C compressor clutch relay internally of underhood fuse block. Once relay closes its internal switch, power from battery is provided to A/C compressor clutch through A/C compressor clutch supply voltage circuit. Whenever compressor is turned off, A/C compressor clutch diode provides a path for voltage spike resulting from collapsing magnetic field of compressor clutch coil. Ground circuit provides a pathway to ground for compressor. A/C clutch relay control circuit is grounded internally within PCM.

Diagnostic System Check

1) Install scan tool. If scan tool powers up, go to next step. If scan tool does not power up, see SCAN TOOL DOES NOT POWER UP in appropriate BODY CONTROL MODULES article.

2) Turn ignition on, engine off. Try to establish scan tool communication with Dash Integration module (DIM), Instrument Panel Module (IPM), Powertrain Control Module (PCM) and rear climate control. If communication with all modules is established, go to next step. If communication with all modules is not established, see SCAN TOOL DOES NOT COMMUNICATE WITH CLASS 2 DEVICE in appropriate BODY CONTROL MODULES article.

3) Select display DTC function for each module. Record all displayed DTCs, status of displayed DTCs and which module set DTCs. If DTCs are displayed, go to next step. If no DTCs are displayed, see COMPRESSOR CLUTCH DOES NOT ENGAGE or COMPRESSOR CLUTCH DOES NOT DISENGAGE.

4) If scan tool displays DTCs beginning with "B", see appropriate SELF-DIAGNOSTICS article in BODY CONTROL MODULES. If scan tool displays DTCs beginning with "P", see appropriate SELF-DIAGNOSTICS article in ENGINE PERFORMANCE. If scan tool displays DTCs beginning with "U", see SCAN TOOL DOES NOT COMMUNICATE WITH CLASS 2 DEVICE in appropriate BODY CONTROL MODULES article.

Compressor Clutch Does Not Engage

1) If diagnostic system check has not been performed, see DIAGNOSTIC SYSTEM CHECK. If diagnostic system check has been performed, go to next step.

2) Ensure outside air temperature is greater than 38°F (3°C). Start engine. Turn blower motor switch to maximum speed position. Press A/C switch to ON position. Place air temperature control switch in coldest position. If A/C compressor operates, problem is intermittent. If A/C compressor does not operate, go to next step.

3) Park vehicle inside or in shade. Open windows in order to ventilate interior of vehicle. If A/C system was operating, then allow A/C system to equalize for about 2 minutes. Turn ignition switch to OFF position. Install Refrigerant Station (J 43600 ACR 2000). Record outside air temperature at vehicle. Record readings of low and high side static pressures. Compare pressure values with specifications for ambient air temperature. See PRESSURE-TEMPERATURE RELATIONSHIP article in GENERAL SERVICING. If pressure values are within specification for

ambient air temperature and within 15 psi (1.1 kg/cm²) of each other, go to next step. If pressure values are not within specification for ambient air temperature or within 15 psi (1.1 kg/cm²) of each other, see LEAK TESTING article in GENERAL SERVICING.

4) Turn ignition switch to ON position, with engine off. Using scan tool, observe A/C HIGH SIDE PRESSURE SENSOR parameter in POWERTRAIN data list. Compare A/C HIGH SIDE PRESSURE on scan tool to high side pressure value on refrigerant station. If high side pressure values are within 15 psi (1.1 kg/cm²) of each other, go to next step. If high side pressure values are not within 15 psi (1.1 kg/cm²) of each other, go to step 20).

5) If HVAC control module (IPM) is inoperative, go to step 19). If HVAC control module (IPM) is not inoperative, go to next step.

6) Start engine. Using scan tool, observe A/C RELAY COMMAND parameter in POWERTRAIN data list. Place air temperature switch in coldest position. Press A/C switch to ON position. If scan tool indicates A/C RELAY COMMAND parameter is ON, go to step 13). If scan tool does not indicate A/C RELAY COMMAND parameter is ON, go to next step.

7) Using scan tool, observe A/C CLUTCH (DESIRED) parameter in DIM A/C INFORMATION list. If scan tool indicates A/C CLUTCH (DESIRED) parameter is ON, go to next step. If scan tool does not indicate A/C CLUTCH (DESIRED) parameter is ON, go to step 9).

8) Using scan tool, observe A/C CLUTCH (ACTUAL) parameter in DIM A/C INFORMATION list. If scan tool indicates A/C CLUTCH (ACTUAL) parameter is ON, go to step 13). If scan tool does not indicate A/C CLUTCH (ACTUAL) parameter is ON, go to step 33).

9) Using scan tool, observe CONTROL HEAD (DESIRED) parameter in DIM A/C INFORMATION list. If scan tool indicates CONTROL HEAD (DESIRED) parameter is ON, go to next step. If scan tool does not indicate CONTROL HEAD (DESIRED) parameter is ON, go to step 12).

10) Using scan tool, observe PRESSURE STATUS parameter in DIM A/C INFORMATION list. If scan tool indicates PRESSURE STATUS parameter is NORMAL, go to next step. If scan tool does not indicate PRESSURE STATUS parameter is NORMAL, problem is intermittent.

11) Using scan tool, observe TEMPERATURE STATUS parameter in DIM A/C INFORMATION list. If scan tool indicates TEMPERATURE STATUS parameter is okay, go to step 30). If scan tool does not indicate TEMPERATURE STATUS is okay, check engine for overheating.

12) Using scan tool, observe CONTROL HEAD (DESIRED) parameter in DIM A/C INFORMATION list. Place mode switch in and out of DEFROST position. If scan tool indicates CONTROL HEAD (DESIRED) parameter turns on and off with each command, go to step 30). If scan tool does not indicate CONTROL HEAD (DESIRED) parameter turns on and off with each command, go to step 32).

13) Using scan tool, command A/C compressor clutch relay on and off. If A/C compressor clutch relay turns on and off with each command, go to step 17). If A/C compressor clutch relay does not turn on and off with each command, go to next step.

14) Turn ignition switch to OFF position. Disconnect A/C compressor clutch relay. Turn ignition switch to ON position, with engine off. Using test light connected to ground, probe coil side voltage supply circuit of A/C compressor clutch relay. If test light is on, go to next step. If test light is off, go to step 27).

15) Connect test light between control circuit (Dark Green/White wire) of A/C compressor clutch relay and coil side voltage supply circuit of A/C compressor clutch relay. Using scan tool, command A/C compressor clutch relay on and off. If test light turns on and off with each command, go to step 29). If test light does not turn on and off with each command, go to next step.

16) If test light remain on with each command, go to step 23). If test light does not remain on with each command, go to step 22).

17) Turn ignition switch to OFF position. Disconnect A/C compressor clutch relay. Using test light connected to ground, probe switch side voltage supply circuit of A/C compressor clutch relay. If test light is on, go to next step. If test light is off, go to step 26).

18) Connect fused jumper (10 amp) between switch side voltage circuit of A/C compressor clutch relay and A/C compressor clutch supply voltage circuit (Dark Green wire) of A/C compressor clutch. Turn ignition switch to ON position, with engine off. If A/C compressor clutch engages, go to step 29). If A/C compressor clutch does not engage, go to step 24).

19) Check ignition voltage circuit (Brown wire) to IPM for a short to ground, high resistance, or open. If problem was found, repair as necessary. After repairs, go to step 40). If problem was not found, go to step 21).

20) Check ground circuit (Black wire or Black/White wire) of A/C pressure sensor for open. If problem was found, repair as necessary. After repairs, go to step 40). If problem was not found, go to step 28).

21) Check ground circuit (Black wire) to IPM for open. If problem was found, repair as necessary. After repairs, go to step 40). If problem was not found, go to step 32).

22) Check control circuit (Dark Green/White wire) of A/C compressor clutch relay for open. If problem was found, repair as necessary. After repairs, go to step 40). If problem was not found, go to step 33).

23) Check control circuit (Dark Green/White wire) of A/C compressor clutch relay for short to ground. If problem was found, repair as necessary. After repairs, go to step 40). If problem was not found, go to step 33).

24) Check A/C compressor clutch supply voltage circuit (Dark Green wire) at A/C compressor clutch for short to ground, high resistance, or open. If problem was found, repair as necessary. After repairs, go to step 40). If problem was not found, go to next step.

25) Check ground circuit (Black wire) of A/C compressor clutch for high resistance or open. If problem was found, repair as necessary. After repairs, go to step 40). If problem was not found, go to step 31).

26) Repair switch side voltage supply circuit of A/C compressor clutch relay. After repairs, go to step 40).

27) Repair coil side voltage supply circuit of A/C compressor clutch relay. After repairs, go to step 40).

28) Check A/C high pressure sensor connector for poor connections. If problem was found, repair as necessary. After repairs, go to step 40). If problem was not found, go to step 35).

29) Check A/C compressor clutch relay connector for poor connections. If problem was found, repair as necessary. After repairs, go to step 40). If problem was not found, go to step 36).

30) Check DIM connector for poor connections. If problem was found, repair as necessary. After repairs, go to step 40). If problem was not found, go to step 34).

31) Check A/C compressor clutch connector for poor connections. If problem was found, repair as necessary. After repairs, go to step 40). If problem was not found, go to step 37).

32) Check IPM connector for poor connections. If problem was found, repair as necessary. After repairs, go to step 40). If problem was not found, go to step 38).

33) Check PCM connectors for poor connections. If problem was found, repair as necessary. After repairs, go to step 40). If problem was not found, go to step 39).

34) Replace DIM. See REMOVAL & INSTALLATION in appropriate BODY CONTROL MODULES article. After repairs, go to step 40).

35) Replace A/C high pressure switch. After repairs, go to

step 40).

36) Replace A/C compressor clutch relay. After repairs, go to step 40).

37) Replace A/C compressor. See appropriate COMPRESSOR SERVICING article in GENERAL SERVICING. After repairs, go to step 40).

38) Replace IPM. See appropriate INSTRUMENT PANELS article in ACCESSORIES & EQUIPMENT. After repairs, go to step 40).

39) Replace PCM. See appropriate REMOVAL, OVERHAUL & INSTALLATION article in ENGINE PERFORMANCE. After repairs, go to next step.

40) Operate system to verify repair.

Compressor Clutch Does Not Disengage

1) If diagnostic system check has not been performed, see DIAGNOSTIC SYSTEM CHECK. If diagnostic system check has been performed, go to next step.

2) Start engine. Turn blower motor switch to OFF position. Place A/C switch in OFF position. If A/C compressor operates, go to next step. If A/C compressor does not operate, problem is intermittent.

3) Using scan tool, observe A/C RELAY COMMAND parameter in POWERTRAIN data list. If scan tool indicates A/C RELAY COMMAND parameter is ON, go to next step. If scan tool does not indicate A/C RELAY COMMAND parameter is ON, go to step 6).

4) Using scan tool, observe CONTROL HEAD (DESIRED) parameter in DIM A/C INFORMATION list. If scan tool displays OFF, go to next step. If scan tool does not display OFF, go to step 11).

5) Using scan tool, observe A/C CLUTCH (DESIRED) parameter in DIM A/C INFORMATION list. If scan tool displays OFF, go to step 13). If scan tool does not display OFF, go to step 12).

6) Turn ignition switch to OFF position. Disconnect A/C compressor clutch relay. Turn ignition switch to ON position. If A/C compressor clutch disengages, go to next step. If A/C compressor clutch does not disengage, go to step 8).

7) Check control circuit (Dark Green/White wire) of A/C compressor clutch relay for short to ground. If problem was found, repair as necessary. After repairs, go to step 19). If problem was not found, go to step 10).

8) Check A/C compressor clutch supply voltage circuit (Dark Green wire) for short to voltage. If problem was found, repair as necessary. After repairs, go to step 19). If problem was not found, go to next step.

9) Check A/C compressor clutch connector for poor connections. If problem was found, repair as necessary. After repairs, go to step 19). If problem was not found, go to step 15).

10) Check A/C compressor clutch relay connector for poor connections. If problem was found, repair as necessary. After repairs, go to step 19). If problem was not found, go to step 14).

11) Check IPM connector for poor connections. If problem was found, repair as necessary. After repairs, go to step 19). If problem was not found, go to step 16).

12) Check DIM connector for poor connections. If problem was found, repair as necessary. After repairs, go to step 19). If problem was not found, go to step 17).

13) Check PCM connectors for poor connections. If problem was found, repair as necessary. After repairs, go to step 19). If problem was not found, go to step 18).

14) Replace A/C compressor clutch relay. After repairs, go to step 19).

15) Replace A/C compressor. See appropriate COMPRESSOR SERVICING article in GENERAL SERVICING. After repairs, go to step 19).

16) Replace IPM. See appropriate INSTRUMENT PANELS article in ACCESSORIES & EQUIPMENT. After repairs, go to step 19).

17) Replace DIM. See REMOVAL & INSTALLATION in appropriate BODY CONTROL MODULES article. After repairs, go to step 19).

18) Replace PCM. See appropriate REMOVAL, OVERHAUL & INSTALLATION article in ENGINE PERFORMANCE. After repairs, go to next step.

19) Operate system to verify repair.

4.6L: ELDORADO

NOTE: For circuit, wire color and terminal identification, see WIRING DIAGRAMS. Also see WIRING DIAGRAMS in appropriate MANUAL or AUTOMATIC A/C HEATER SYSTEMS article.

NOTE: Since many DTCs cause PCM to disable compressor clutch operation, any DTCs stored in memory must be repaired and cleared before proceeding. See appropriate SELF-DIAGNOSTICS article in ENGINE PERFORMANCE.

Description

HVAC control module is interface between vehicle operator and HVAC control processor. When an A/C request is selected, a signal is sent from HVAC control processor to Powertrain Control Module (PCM). PCM monitors A/C refrigerant line pressure, A/C refrigerant temperatures and engine coolant temperature. If all PCM signals are normal, A/C clutch relay control circuit will be grounded, allowing A/C compressor to engage. If there is a malfunction in A/C system, driver information center will read either SERVICE A/C SYSTEM or LOW REFRIG. A/C OFF to alert vehicle operator that there is a malfunction with A/C system.

PCM turns on A/C compressor by providing a path to ground through A/C clutch relay control circuit for A/C compressor clutch relay. Power is provided to A/C compressor clutch relay from underhood fuse/relay block on A/C low pressure switch signal circuit and both A/C pressure switches. Once relay closes its internal switch, power from battery is provided to A/C compressor clutch through A/C compressor clutch supply voltage circuit. Ground circuit provides a path to ground for compressor. A/C clutch relay control circuit is grounded internally within PCM.

PCM will open A/C clutch relay control circuit when coolant temperatures get too hot or there is a loss of refrigerant. When engine coolant temperatures reach 259°F (126°C), PCM will open A/C clutch relay control circuit. When PCM reads wide open throttle, PCM will shut off compressor for 20 seconds.

Diagnostic System Check

1) Install scan tool. If scan tool powers up, go to next step. If scan tool does not power up, see SCAN TOOL DOES NOT POWER UP in appropriate BODY CONTROL MODULES article.

2) Turn ignition on, engine off. Try to establish scan tool communication with HVAC control module, Body Control Module (BCM) and Powertrain Control Module (PCM). If communication with all modules is established, go to next step. If communication with all modules is not established, see SCAN TOOL DOES NOT COMMUNICATE WITH CLASS 2 DEVICE in appropriate BODY CONTROL MODULES article.

3) Select display DTC function for each module. Record all displayed DTCs, status of displayed DTCs and which module set DTCs. If DTCs are displayed, go to next step. If no DTCs are displayed, see COMPRESSOR CLUTCH DOES NOT ENGAGE or COMPRESSOR CLUTCH DOES NOT DISENGAGE.

4) If scan tool displays DTCs beginning with "B", see appropriate SELF-DIAGNOSTICS article in BODY CONTROL MODULES. If scan

tool displays DTCs beginning with "P", see appropriate SELF-DIAGNOSTICS article in ENGINE PERFORMANCE. If scan tool displays DTCs beginning with "U", see SCAN TOOL DOES NOT COMMUNICATE WITH CLASS 2 DEVICE in appropriate BODY CONTROL MODULES article.

Compressor Clutch Does Not Engage

1) If diagnostic system check has not been performed, see DIAGNOSTIC SYSTEM CHECK. If diagnostic system check has been performed, go to next step.

2) Ensure outside air temperature is greater than 38°F (3°C). Start engine. Turn blower motor switch to maximum speed position. Place A/C request switch in ON position. Place air temperature control switch in coldest position. If A/C compressor operates, problem is intermittent. If A/C compressor does not operate, go to next step.

3) Park vehicle inside or in shade. Open windows in order to ventilate interior of vehicle. If A/C system was operating, then allow A/C system to equalize for about 2 minutes. Turn ignition switch to OFF position. Install Refrigerant Station (J 43600 ACR 2000). Record outside air temperature at vehicle. Record readings of low and high side static pressures. Compare pressure values with specifications for ambient air temperature. See PRESSURE-TEMPERATURE RELATIONSHIP article in GENERAL SERVICING. If pressure values are within specification for ambient air temperature and within 15 psi (1.1 kg/cm²) of each other, go to next step. If pressure values are not within specification for ambient air temperature or within 15 psi (1.1 kg/cm²) of each other, see LEAK TESTING article in GENERAL SERVICING.

4) If HVAC control module is inoperative, go to step 6). If HVAC control module is not inoperative, go to next step.

5) Turn ignition switch to ON position, with engine off. Using scan tool, observe A/C OFF SWITCH parameter in CLIMATE CONTROL PANEL (CCP) inputs. Cycle A/C switch on and off. If scan tool parameter turns on and off each time switch is pressed, go to step 8). If scan tool parameter does not turn on and off each time switch is pressed, go to step 31).

6) Check battery voltage circuit (Orange wire) to HVAC control module for short to ground, high resistance, or open. If problem was found, repair as necessary. After repairs, go to step 42). If problem was not found, go to next step.

7) Test ground circuit (Black/White wire and Black wire) of HVAC control module for open or high resistance. If problem was found, repair as necessary. After repairs, go to step 42). If problem was not found, go to step 31).

8) Turn ignition switch to ON position, with engine off. If A/C system was operating, allow A/C system to equalize for approximately 2 minutes. Using scan tool, observe A/C HIGH and LOW REFRIGERANT PRESSURE SWITCHES in HEATING AND AIR CONDITIONING inputs. If scan tool indicates both HIGH and LOW REFRIGERANT PRESSURE SWITCHES are CLOSED, go to step 12). If scan tool does not indicate both HIGH and LOW REFRIGERANT PRESSURE SWITCHES are CLOSED, go to next step.

9) If scan tool indicates high refrigerant pressure switch is open, go to next step. If scan tool does not indicate high refrigerant pressure switch is open, go to step 11).

10) Turn ignition switch to OFF position. Disconnect A/C high pressure switch. Connect fused jumper (3 amp) across A/C high pressure switch connector. Start engine. Using scan tool, observe HIGH REFRIGERANT PRESSURE SWITCH parameter. If scan tool indicates HIGH REFRIGERANT PRESSURE SWITCH parameter is CLOSED, go to step 33). If scan tool does not indicate HIGH REFRIGERANT PRESSURE SWITCH parameter is CLOSED, go to step 14).

11) Turn ignition switch to OFF position. Disconnect A/C low pressure switch. Connect fused jumper (3 amp) across A/C low pressure switch connector. Start engine. Using scan tool, observe LOW REFRIGERANT PRESSURE SWITCH parameter. If scan tool indicates LOW

REFRIGERANT PRESSURE SWITCH parameter is CLOSED, go to step 29). If scan tool does not indicate LOW REFRIGERANT PRESSURE SWITCH parameter is CLOSED, go to step 15).

12) Start engine. Using scan tool, observe A/C POSSIBLE parameter in HEATING AND AIR CONDITIONING inputs. Place A/C in ON position. If scan tool indicates A/C POSSIBLE parameter is ON, go to next step. If scan tool does not indicate A/C POSSIBLE parameter is ON, go to step 32).

13) Start engine. Using scan tool, observe COMMANDED A/C parameter in POWERTRAIN data list. Place air temperature switch in coldest position. Place A/C in ON position. If scan tool indicates COMMANDED A/C parameter is ON, go to step 16). If scan tool does not indicate COMMAND A/C parameter is ON, go to step 34).

14) Turn ignition switch to OFF position. Reconnect A/C high pressure switch. Check A/C high pressure switch input circuit (Dark Blue wire) for short to ground, high resistance, or open. If problem is found, repair as necessary. After repairs, go to step 42). If problem is not found, go to step 34).

15) Turn ignition switch to OFF position. Connect A/C low pressure switch. Check A/C low pressure switch input circuit (Dark Green wire) for short to ground, high resistance, or open. If problem is found, repair as necessary. After repairs, go to step 42). If problem is not found, go to step 34).

16) Using scan tool, command A/C compressor clutch relay on and off. If A/C compressor clutch relay turns on and off with each command, go to next step. If A/C compressor clutch relay does not turn on and off with each command, go to step 19).

17) Turn ignition switch to OFF position. Disconnect A/C compressor clutch relay. Using test light connected to ground, probe switch side voltage supply circuit (Orange wire) of A/C compressor clutch relay. If test light is on, go to next step. If test light is off, go to step 27).

18) Connect fused jumper (10 amp) between switch side voltage circuit (Orange wire) of A/C compressor clutch relay and A/C compressor clutch supply voltage circuit (Dark Green wire) of A/C compressor clutch. Turn ignition switch to ON position, with engine off. If A/C compressor clutch engages, go to step 28). If A/C compressor clutch does not engage, go to step 22).

19) Turn ignition switch to OFF position. Disconnect A/C compressor clutch relay. Turn ignition switch to ON position, with engine off. Using test light connected to ground, probe coil side voltage supply circuit (Dark Blue wire) of A/C compressor clutch relay. If test light is on, go to next step. If test light is off, go to step 26).

20) Connect test light between control circuit (Dark Green/White wire) of A/C compressor clutch relay and coil side voltage supply circuit (Dark Green wire) of A/C compressor clutch relay. Using scan tool, command A/C compressor clutch relay on and off. If test light turns on and off with each command, go to step 28).

21) If test light remains on with each command, go to step 24). If test light does not remain on, go to step 25).

22) Check A/C compressor clutch supply voltage circuit (Dark Green wire) at A/C compressor clutch for short to ground, high resistance, or open. If problem was found, repair as necessary. After repairs, go to step 42). If problem was not found, go to next step.

23) Check ground circuit (Black wire) of A/C compressor clutch for high resistance or open. If problem was found, repair as necessary. After repairs, go to step 42). If problem was not found, go to step 30).

24) Check control circuit (Dark Green/White wire) of A/C compressor clutch relay for short to ground. If problem was found, repair as necessary. After repairs, go to step 42). If problem was not found, go to step 34).

25) Check control circuit (Dark Green/White wire) of A/C compressor clutch relay for open. If problem was found, repair as necessary. After repairs, go to step 42). If problem was not found, go to step 34).

26) Repair coil side voltage supply circuit (Dark Blue wire) of A/C compressor clutch relay. After repairs, go to step 42).

27) Repair switch side voltage supply circuit (Orange wire) of A/C compressor clutch relay. After repairs, go to step 42).

28) Check A/C compressor clutch relay connector for poor connections. If problem was found, repair as necessary. After repairs, go to step 42). If problem was not found, go to step 35).

29) Check A/C low pressure switch connector for poor connections. If problem was found, repair as necessary. After repairs, go to step 42). If problem was not found, go to step 36).

30) Check A/C compressor clutch connector for poor connections. If problem was found, repair as necessary. After repairs, go to step 42). If problem was not found, go to step 39).

31) Check HVAC control module connector for poor connections. If problem was found, repair as necessary. After repairs, go to step 42). If problem was not found, go to step 40).

32) Check heater and A/C programmer connector for poor connections. If problem was found, repair as necessary. After repairs, go to step 42). If problem was not found, go to step 38).

33) Check A/C high pressure switch connector for poor connections. If problem was found, repair as necessary. After repairs, go to step 42). If problem was not found, go to step 37).

34) Check PCM connectors for poor connections. If problem was found, repair as necessary. After repairs, go to step 42). If problem was not found, go to step 41).

35) Replace A/C compressor clutch relay. After repairs, go to step 42).

36) Replace A/C low pressure switch. After repairs, go to step 42).

37) Replace A/C high pressure switch. After repairs, go to step 42).

38) Replace HVAC control processor. See REMOVAL & INSTALLATION in appropriate AUTOMATIC A/C-HEATER SYSTEMS article. After repairs, go to step 42).

39) Replace A/C compressor clutch coil. See appropriate COMPRESSOR SERVICING article in GENERAL SERVICING. After repairs, go to step 42).

40) Replace HVAC control module. See REMOVAL & INSTALLATION in appropriate AUTOMATIC A/C-HEATER SYSTEMS article. After repairs, go to step 42).

41) Replace PCM. See appropriate REMOVAL, OVERHAUL & INSTALLATION article in ENGINE PERFORMANCE. After repairs, go to next step.

42) Operate system to verify repair.

Compressor Clutch Does Not Disengage

1) If diagnostic system check has not been performed, see DIAGNOSTIC SYSTEM CHECK. If diagnostic system check has been performed, go to next step.

2) Start engine. Place A/C switch in OFF position. If A/C compressor operates, go to next step. If A/C compressor does not operate, problem is intermittent.

3) Using scan tool, observe A/C OFF SWITCH parameter in CLIMATE CONTROL PANEL (CCP). If scan tool indicates A/C OFF SWITCH parameter is OFF, go to next step. If scan tool does not indicate A/C OFF SWITCH parameter is OFF, go to step 12).

4) Using scan tool, observe A/C COMMAND parameter in HEATING AND AIR CONDITIONING inputs. If scan tool displays NO, go to next step. If scan tool does not display NO, go to step 13).

5) Using scan tool, observe A/C RELAY COMMAND parameter in POWERTRAIN data List 2. If scan tool displays OFF, go to next step. If scan tool does not display OFF, go to step 14).

6) Turn ignition switch to OFF position. Disconnect A/C compressor clutch relay. Turn ignition switch to ON position. If A/C compressor clutch disengages, go to next step. If A/C compressor clutch does not disengage, go to step 9).

7) Measure resistance between switch side A/C compressor clutch relay terminals. If resistance is infinite, go to next step. If resistance is not infinite, go to step 11).

8) Check control circuit (Dark Green/White wire) of A/C compressor clutch relay for short to ground. If problem was found, repair as necessary. After repairs, go to step 20). If problem was not found, go to step 14).

9) Check A/C compressor clutch supply voltage circuit (Dark Green wire) for short to voltage. If problem was found, repair as necessary. After repairs, go to step 20). If problem was not found, go to next step.

10) Check A/C compressor clutch connector for poor connections. If problem was found, repair as necessary. After repairs, go to step 20). If problem was not found, go to step 16).

11) Check A/C compressor clutch relay connector for poor connections. If problem was found, repair as necessary. After repairs, go to step 20). If problem was not found, go to step 15).

12) Check HVAC control module connector for poor connections. If problem was found, repair as necessary. After repairs, go to step 20). If problem was not found, go to step 17).

13) Check HVAC control processor connector for poor connections. If problem was found, repair as necessary. After repairs, go to step 20). If problem was not found, go to step 18).

14) Check PCM connectors for poor connections. If problem was found, repair as necessary. After repairs, go to step 20). If problem was not found, go to step 19).

15) Replace A/C compressor clutch relay. After repairs, go to step 20).

16) Replace A/C compressor clutch hub and plate. See appropriate COMPRESSOR SERVICING article in GENERAL SERVICING. After repairs, go to step 20).

17) Replace HVAC control module. See REMOVAL & INSTALLATION in appropriate AUTOMATIC A/C-HEATER SYSTEMS article. After repairs, go to step 20).

18) Replace HVAC control processor. See REMOVAL & INSTALLATION in appropriate AUTOMATIC A/C-HEATER SYSTEMS article. After repairs, go to step 20).

19) Replace PCM. See appropriate REMOVAL, OVERHAUL & INSTALLATION article in ENGINE PERFORMANCE. After repairs, go to next step.

20) Operate system to verify repair.

5.7L: CORVETTE

NOTE: For circuit, wire color and terminal identification, see WIRING DIAGRAMS. Also see WIRING DIAGRAMS in appropriate MANUAL or AUTOMATIC A/C HEATER SYSTEMS article.

Description

The A/C clutch relay is PCM controlled to delay A/C compressor clutch engagement after A/C is turned on. This allows PCM to adjust engine RPM before the A/C compressor clutch engages. The PCM will engage compressor clutch any time A/C has been requested, unless one or more of the following conditions occur:

- * Coolant temperature is high.

- * A/C system pressure is low.
- * A/C system pressure is high.
- * During wide open throttle.
- * High engine RPM.
- * Certain DTCs are set.

When A/C-heater control panel is placed in A/C mode, a 12-volt signal is sent to PCM. When PCM receives this signal, PCM will ground A/C clutch relay control circuit to energize A/C clutch relay. This is shown on scan tool as A/C REQUEST YES.

When an A/C request has been detected by PCM, the PCM will ground A/C clutch relay control circuit. As a result, relay contacts close, allowing current to flow through relay to compressor clutch. When A/C REQUEST has been detected by PCM, cooling fans will turn on when A/C system pressure is greater than a predetermined value.

Diagnostic System Check (Automatic A/C)

- 1) Install scan tool. If scan tool powers up, go to next step. If scan tool does not power up, see SCAN TOOL DOES NOT POWER UP in appropriate BODY CONTROL MODULES article.
- 2) Turn ignition on, engine off. Try to establish scan tool communication with HVAC control module, Body Control Module (BCM) and Powertrain Control Module (PCM). If communication with all modules is established, go to next step. If communication with all modules is not established, see SCAN TOOL DOES NOT COMMUNICATE WITH CLASS 2 DEVICE in appropriate BODY CONTROL MODULES article.
- 3) Select display DTC function for each module. Record all displayed DTCs, status of displayed DTCs and which module set DTCs. If DTCs are displayed, go to next step. If no DTCs are displayed, see COMPRESSOR CLUTCH DOES NOT ENGAGE (AUTOMATIC A/C) or COMPRESSOR CLUTCH DOES NOT DISENGAGE (AUTOMATIC A/C).
- 4) If scan tool displays DTCs beginning with "B", see appropriate SELF-DIAGNOSTICS article in BODY CONTROL MODULES. If scan tool displays DTCs beginning with "P", see appropriate SELF-DIAGNOSTICS article in ENGINE PERFORMANCE. If scan tool displays DTCs beginning with "U", see SCAN TOOL DOES NOT COMMUNICATE WITH CLASS 2 DEVICE in appropriate BODY CONTROL MODULES article.

Diagnostic System Check (Manual A/C)

- 1) Install scan tool. If scan tool powers up, go to next step. If scan tool does not power up, see SCAN TOOL DOES NOT POWER UP in appropriate BODY CONTROL MODULES article.
- 2) Turn ignition on, engine off. Try to establish scan tool communication with Powertrain Control Module (PCM). If communication with PCM is established, go to next step. If communication with PCM is not established, see SCAN TOOL DOES NOT COMMUNICATE WITH CLASS 2 DEVICE in appropriate BODY CONTROL MODULES article.
- 3) Select display DTC function for PCM. Record all displayed DTCs and status of displayed DTCs. If DTCs are displayed, go to next step. If no DTCs are displayed, see COMPRESSOR CLUTCH DOES NOT ENGAGE (MANUAL A/C) or COMPRESSOR CLUTCH DOES NOT DISENGAGE (MANUAL A/C).
- 4) If scan tool does not display DTCs beginning with "U", see appropriate SELF-DIAGNOSTICS article in ENGINE PERFORMANCE. If scan tool displays DTCs beginning with "U", see SCAN TOOL DOES NOT COMMUNICATE WITH CLASS 2 DEVICE in appropriate BODY CONTROL MODULES article.

Compressor Clutch Does Not Engage (Automatic A/C)

- 1) If diagnostic system check has not been performed, see DIAGNOSTIC SYSTEM CHECK (AUTOMATIC A/C). If diagnostic system check has been performed, go to next step.
- 2) Ensure outside air temperature is greater than 38°F (3°C).

Start engine. Turn blower motor switch to maximum speed position. Place A/C request switch in ON position. Place air temperature control switch in coldest position. If A/C compressor operates, problem is intermittent. If A/C compressor does not operate, go to next step.

3) Park vehicle inside or in shade. Open windows in order to ventilate interior of vehicle. If A/C system was operating, then allow A/C system to equalize for about 2 minutes. Turn ignition switch to OFF position. Install Refrigerant Station (J 43600 ACR 2000). Record outside air temperature at vehicle. Record readings of low and high side static pressures. Compare pressure values with specifications for ambient air temperature. See PRESSURE-TEMPERATURE RELATIONSHIP article in GENERAL SERVICING. If pressure values are within specification for ambient air temperature and within 15 psi (1.1 kg/cm²) of each other, go to next step. If pressure values are not within specification for ambient air temperature or within 15 psi (1.1 kg/cm²) of each other, see LEAK TESTING article in GENERAL SERVICING.

4) Turn ignition switch to ON position, with engine off. Using scan tool, observe A/C HIGH SIDE PRESSURE parameter in POWERTRAIN data list. Compare A/C HIGH SIDE PRESSURE parameter on scan tool to high side pressure value on refrigerant station. If high side pressure values are within 15 psi (1.1 kg/cm²) of each other, go to next step. If high side pressure values are not within 15 psi (1.1 kg/cm²) of each other, go to step 15).

5) If HVAC control module is inoperative, go to step 14). If HVAC control module is not inoperative, go to next step.

6) Start engine. Using scan tool, observe A/C REQUEST SIGNAL parameter in POWERTRAIN data list. Place air temperature switch in coldest position. Place A/C request switch in ON position. If scan tool indicates A/C REQUEST SIGNAL parameter is YES, go to next step. If scan tool does not indicate A/C REQUEST SIGNAL parameter is YES, go to step 26).

7) Using scan tool, observe A/C RELAY COMMAND STATUS in POWERTRAIN data list. If scan tool indicates A/C RELAY COMMAND STATUS is ON, go to next step. If scan tool does not indicate A/C RELAY COMMAND STATUS is ON, go to step 27).

8) Using scan tool, command A/C compressor clutch relay on and off. If A/C compressor clutch relay turns on and off with each command, go to step 12). If A/C compressor clutch relay does not turn on and off with each command, go to next step.

9) Turn ignition switch to OFF position. Disconnect A/C compressor clutch relay. Turn ignition switch to ON position, with engine off. Using test light connected to ground, probe coil side voltage supply circuit of A/C compressor clutch relay. If test light is on, go to next step. If test light is off, go to step 22).

10) Connect test light between control circuit (Dark Green/White wire) of A/C compressor clutch relay and coil side voltage supply circuit of A/C compressor clutch relay. Using scan tool, command A/C compressor clutch relay on and off. If test light turns on and off with each command, go to step 24). If test light does not turn on and off with each command, go to next step.

11) If test light remains on with each command, go to step 18). If test light does not remain on with each command, go to step 17).

12) Turn ignition switch to OFF position. Disconnect A/C compressor clutch relay. Using test light connected to ground, probe switch side voltage supply circuit of A/C compressor clutch relay. If test light is on, go to next step. If test light is off, go to step 21).

13) Connect fused jumper (10 amp) between switch side voltage circuit of A/C compressor clutch relay and A/C compressor clutch supply voltage circuit (Dark Green wire) of A/C compressor clutch. Turn ignition switch to ON position, with engine off. If A/C compressor clutch engages, go to step 24). If A/C compressor clutch

does not engage, go to step 19).

14) Check ignition voltage circuit (Brown wire) of HVAC control module for short to ground, high resistance, or open. If problem was found, repair as necessary. After repairs, go to step 33). If problem was not found, go to step 16).

15) Check low reference circuit (Black wire) of A/C refrigerant pressure sensor for open. If problem was found, repair as necessary. After repairs, go to step 33). If problem was not found, go to step 23).

16) Check ground circuit (Black wire) of HVAC control module for open. If problem was found, repair as necessary. After repairs, go to step 33). If problem was not found, go to step 26).

17) Check control circuit (Dark Green/White wire) of A/C compressor clutch relay for open. If problem was found, repair as necessary. After repairs, go to step 33). If problem was not found, go to step 27).

18) Check control circuit (Dark Green/White wire) of A/C compressor clutch relay for short to ground. If problem was found, repair as necessary. After repairs, go to step 33). If problem was not found, go to step 27).

19) Check A/C compressor clutch supply voltage circuit (Dark Green wire) at A/C compressor clutch for short to ground, high resistance, or open. If problem was found, repair as necessary. After repairs, go to step 33). If problem was not found, go to next step.

20) Check ground circuit (Black wire) of A/C compressor clutch for high resistance or open. If problem was found, repair as necessary. After repairs, go to step 33). If problem was not found, go to step 25).

21) Repair switch side voltage supply circuit of A/C compressor clutch relay. After repairs, go to step 33).

22) Repair coil side voltage supply circuit of A/C compressor clutch relay. After repairs, go to step 33).

23) Check A/C high pressure sensor connector for poor connections. If problem was found, repair as necessary. After repairs, go to step 33). If problem was not found, go to step 28).

24) Check A/C compressor clutch relay connector for poor connections. If problem was found, repair as necessary. After repairs, go to step 33). If problem was not found, go to step 29).

25) Check A/C compressor clutch connector for poor connections. If problem was found, repair as necessary. After repairs, go to step 33). If problem was not found, go to step 30).

26) Check HVAC control module connector for poor connections. If problem was found, repair as necessary. After repairs, go to step 33). If problem was not found, go to step 31).

27) Check PCM connectors for poor connections. If problem was found, repair as necessary. After repairs, go to step 33). If problem was not found, go to step 32).

28) Replace A/C refrigerant pressure sensor. After repairs, go to step 33).

29) Replace A/C compressor clutch relay. After repairs, go to step 33).

30) Replace A/C compressor clutch coil. See appropriate COMPRESSOR SERVICING article in GENERAL SERVICING. After repairs, go to step 33).

31) Replace HVAC control module. See REMOVAL & INSTALLATION in appropriate AUTOMATIC A/C-HEATER SYSTEMS article. After repairs, go to step 33).

32) Replace PCM. See appropriate REMOVAL, OVERHAUL & INSTALLATION article in ENGINE PERFORMANCE. After repairs, go to next step.

33) Operate system to verify repair.

Compressor Clutch Does Not Engage (Manual A/C)

1) If diagnostic system check has not been performed, see DIAGNOSTIC SYSTEM CHECK (MANUAL A/C). If diagnostic system check has been performed, go to next step.

2) Ensure outside air temperature is greater than 38°F (3°C). Start engine. Turn blower motor switch to maximum speed position. Place A/C request switch in ON position. Place air temperature control switch in coldest position. If A/C compressor operates, problem is intermittent. If A/C compressor does not operate, go to next step.

3) Park vehicle inside or in shade. Open windows in order to ventilate interior of vehicle. If A/C system was operating, then allow A/C system to equalize for about 2 minutes. Turn ignition switch to OFF position. Install Refrigerant Station (J 43600 ACR 2000). Record outside air temperature at vehicle. Record readings of low and high side static pressures. Compare pressure values with specifications for ambient air temperature. See PRESSURE-TEMPERATURE RELATIONSHIP article in GENERAL SERVICING. If pressure values are within specification for ambient air temperature and within 15 psi (1.1 kg/cm²) of each other, go to next step. If pressure values are not within specification for ambient air temperature or within 15 psi (1.1 kg/cm²) of each other, see LEAK TESTING article in GENERAL SERVICING.

4) Turn ignition switch to ON position, with engine off. Using scan tool, observe A/C HIGH SIDE PRESSURE SENSOR parameter in POWERTRAIN data list. Compare A/C HIGH SIDE PRESSURE on scan tool to high side pressure value on refrigerant station. If high side pressure values are within 15 psi (1.1 kg/cm²) of each other, go to next step. If high side pressure values are not within 15 psi (1.1 kg/cm²) of each other, go to step 17).

5) If HVAC control module is inoperative, go to step 16). If HVAC control module is not inoperative, go to next step.

6) Start engine. Using scan tool, observe A/C REQUEST parameter in POWERTRAIN data list. Place air temperature switch in coldest position. Turn blower motor to ON position. Place A/C REQUEST switch in ON position. If scan tool indicates A/C REQUEST parameter is ON, go to step 10). If scan tool does not indicate A/C REQUEST parameter is ON, go to next step.

7) If A/C request indicator is on, go to step 9). If A/C request indicator is not on, go to next step.

8) Ensure blower motor switch is in ON position. Turn ignition switch to ON position. Check blower motor off circuit (Light Green wire) at HVAC control module for short to voltage. If problem was found, repair as necessary. After repairs, go to step 35). If problem was not found, go to step 28).

9) Turn ignition switch to OFF position. Check A/C request signal circuit (Dark Green/White wire) for short to ground, high resistance, or open. If problem was found, repair as necessary. After repairs, go to step 35). If problem was not found, go to step 29).

10) Using scan tool, command A/C compressor clutch relay on and off. If A/C compressor clutch relay turns on and off with each command, go to step 14). If A/C compressor clutch relay does not turn on and off with each command, go to next step.

11) Turn ignition switch to OFF position. Disconnect A/C compressor clutch relay. Turn ignition switch to ON position, with engine off. Using test light connected to ground, probe coil side voltage supply circuit of A/C compressor clutch relay. If test light is on, go to next step. If test light is off, go to step 24).

12) Connect test light between control circuit (Dark Green/White wire) of A/C compressor clutch relay and coil side voltage supply circuit of A/C compressor clutch relay. Using scan tool, command A/C compressor clutch relay on and off. If test light turns on and off with each command, go to step 26). If test light does not turn on and off with each command, go to next step.

13) If test light remains on with each command, go to step 20). If test light does not remain on with each command, go to step

19).

14) Turn ignition switch to OFF position. Disconnect A/C compressor clutch relay. Using test light connected to ground, probe switch side voltage supply circuit of A/C compressor clutch relay. If test light is on, go to next step. If test light is off, go to step 23).

15) Connect fused jumper (10 amp) between switch side voltage circuit of A/C compressor clutch relay and A/C compressor clutch supply voltage circuit (Dark Green wire) of A/C compressor clutch. Turn ignition switch to ON position, with engine off. If A/C compressor clutch engages, go to step 26). If A/C compressor clutch does not engage, go to step 21).

16) Check ignition voltage circuit (Brown wire) of HVAC control module for short to ground, high resistance, or open. If problem was found, repair as necessary. After repairs, go to step 35). If problem was not found, go to step 18).

17) Check ground circuit (Black wire) of A/C refrigerant pressure sensor for open. If problem was found, repair as necessary. After repairs, go to step 35). If problem was not found, go to step 25).

18) Check ground circuit (Black wire) of HVAC control module for open. If problem was found, repair as necessary. After repairs, go to step 35). If problem was not found, go to step 28).

19) Check control circuit (Dark Green/White wire) of A/C compressor clutch relay for open. If problem was found, repair as necessary. After repairs, go to step 35). If problem was not found, go to step 29).

20) Check control circuit (Dark Green/White wire) of A/C compressor clutch relay for short to ground. If problem was found, repair as necessary. After repairs, go to step 35). If problem was not found, go to step 29).

21) Check A/C compressor clutch supply voltage circuit (Dark Green wire) at A/C compressor clutch for short to ground, high resistance or open. If problem was found, repair as necessary. After repairs, go to step 35). If problem was not found, go to next step.

22) Check ground circuit (Black wire) of A/C compressor clutch for high resistance or open. If problem was found, repair as necessary. After repairs, go to step 35). If problem was not found, go to step 27).

23) Repair switch side voltage supply circuit of the A/C compressor clutch relay. After repairs, go to step 35).

24) Repair coil side voltage supply circuit of the A/C compressor clutch relay. After repairs, go to step 35).

25) Check A/C refrigerant pressure sensor connector for poor connections. If problem was found, repair as necessary. After repairs, go to step 35). If problem was not found, go to step 30).

26) Check A/C compressor clutch relay connector for poor connections. If problem was found, repair as necessary. After repairs, go to step 35). If problem was not found, go to step 31).

27) Check A/C compressor clutch connector for poor connections. If problem was found, repair as necessary. After repairs, go to step 35). If problem was not found, go to step 32).

28) Check HVAC control module connector for poor connections. If problem was found, repair as necessary. After repairs, go to step 35). If problem was not found, go to step 33).

29) Check PCM connectors for poor connections. If problem was found, repair as necessary. After repairs, go to step 35). If problem was not found, go to step 34).

30) Replace A/C refrigerant pressure sensor. After repairs, go to step 35).

31) Replace A/C compressor clutch relay. After repairs, go to step 35).

32) Replace A/C compressor clutch coil. See appropriate

COMPRESSOR SERVICING article in GENERAL SERVICING. After repairs, go to step 35).

33) Replace HVAC control module. See REMOVAL & INSTALLATION in appropriate MANUAL A/C-HEATER SYSTEMS article. After repairs, go to step 35).

34) Replace PCM. See appropriate REMOVAL, OVERHAUL & INSTALLATION article in ENGINE PERFORMANCE. After repairs, go to next step.

35) Operate system to verify repair.

Compressor Clutch Does Not Disengage (Automatic A/C)

1) If diagnostic system check has not been performed, see DIAGNOSTIC SYSTEM CHECK (AUTOMATIC A/C). If diagnostic system check has been performed, go to next step.

2) Start engine. Place blower motor switch in OFF position. Place A/C request switch in OFF position. If A/C compressor operates, go to next step. If A/C compressor does not operate, problem is intermittent.

3) Using scan tool, observe A/C RELAY COMMAND parameter in POWERTRAIN data list. If scan tool indicates A/C RELAY COMMAND parameter is ON, go to next step. If scan tool does not indicate A/C RELAY COMMAND parameter is ON, go to step 5).

4) Using scan tool, observe A/C REQUEST SIGNAL parameter in POWERTRAIN data list. If scan tool indicates A/C REQUEST SIGNAL parameter is YES, go to step 10). If scan tool does not indicate A/C REQUEST SIGNAL parameter is YES, go to step 11).

5) Remove A/C compressor clutch relay. If A/C compressor clutch turns OFF, go to next step. If A/C compressor clutch does not turn off, go to step 8).

6) Measure resistance between switch side A/C compressor clutch relay terminals. If resistance is infinite, go to next step. If resistance is not infinite, go to step 9).

7) Check A/C clutch relay control circuit (Dark Green/White wire) for short to ground. If problem was found, repair as necessary. After repairs, go to step 16). If problem was not found, go to step 11).

8) Check A/C compressor clutch supply voltage circuit (Dark Green wire) for short to voltage. If problem was found, repair as necessary. After repairs, go to step 16). If problem was not found, go to step 13).

9) Check A/C compressor clutch relay connector for poor connections. If problem was found, repair as necessary. After repairs, go to step 16). If problem was not found, go to step 12).

10) Check HVAC control module connector for poor connections. If problem was found, repair as necessary. After repairs, go to step 16). If problem was not found, go to step 14).

11) Check PCM connectors for poor connections. If problem was found, repair as necessary. After repairs, go to step 16). If problem was not found, go to step 15).

12) Replace A/C compressor clutch relay. After repairs, go to step 16).

13) Replace A/C compressor clutch. See appropriate COMPRESSOR SERVICING article in GENERAL SERVICING. After repairs, go to step 16).

14) Replace HVAC control module. See REMOVAL & INSTALLATION in appropriate AUTOMATIC A/C-HEATER SYSTEMS article. After repairs, go to step 16).

15) Replace PCM. See appropriate REMOVAL, OVERHAUL & INSTALLATION article in ENGINE PERFORMANCE. After repairs, go to next step.

16) Operate system to verify repair.

Compressor Clutch Does Not Disengage (Manual A/C)

1) If diagnostic system check has not been performed, see

DIAGNOSTIC SYSTEM CHECK (MANUAL A/C). If diagnostic system check has been performed, go to next step.

2) Start engine. Place blower motor switch in OFF position. Place A/C request switch in OFF position. If A/C compressor operates, go to next step. If A/C compressor does not operate, problem is intermittent.

3) Using scan tool, observe A/C REQUEST parameter in POWERTRAIN data list. If scan tool indicates A/C REQUEST parameter is ON, go to next step. If scan tool does not indicate A/C REQUEST parameter is ON, go to step 6).

4) Check A/C request signal circuit (Dark Green/White wire) for short to ground. If problem was found, repair as necessary. After repairs, go to step 17). If problem was not found, go to next step.

5) Turn ignition switch to OFF position. Disconnect HVAC control module connector. Back out terminal for A/C request circuit (Dark Green/White wire) from HVAC control module connector. Reconnect HVAC control module connector. Start engine. Using scan tool, observe A/C REQUEST parameter. If scan tool indicates A/C REQUEST parameter is ON, go to step 12). If scan tool does not indicate A/C REQUEST parameter in ON, go to step 11).

6) Remove A/C compressor clutch relay. If A/C compressor clutch turns off, go to next step. If A/C compressor clutch does not turn off, go to step 9).

7) Measure resistance between switch side A/C compressor clutch relay terminals. If resistance is infinite, go to next step. If resistance is not infinite, go to step 10).

8) Check A/C clutch relay control circuit (Dark Green/White wire) for short to ground. If problem was found, repair as necessary. After repairs, go to step 17). If problem was not found, go to step 12).

9) Check A/C compressor clutch supply voltage circuit (Dark Green wire) for short to voltage. If problem was found, repair as necessary. After repairs, go to step 17). If problem was not found, go to step 14).

10) Check A/C compressor clutch relay connector for poor connections. If problem was found, repair as necessary. After repairs, go to step 17). If problem was not found, go to step 13).

11) Check HVAC control module connector for poor connections. If problem was found, repair as necessary. After repairs, go to step 17). If problem was not found, go to step 15).

12) Check PCM connectors for poor connections. If problem was found, repair as necessary. After repairs, go to step 17). If problem was not found, go to step 16).

13) Replace A/C compressor clutch relay. After repairs, go to step 17).

14) Replace A/C compressor clutch. See appropriate COMPRESSOR SERVICING article in GENERAL SERVICING. After repairs, go to step 17).

15) Replace HVAC control module. See REMOVAL & INSTALLATION in appropriate MANUAL A/C-HEATER SYSTEMS article. After repairs, go to step 17).

16) Replace PCM. See appropriate REMOVAL, OVERHAUL & INSTALLATION article in ENGINE PERFORMANCE. After repairs, go to next step.

17) Operate system to verify repair.

A/C CLUTCH CIRCUIT DIAGNOSIS (LIGHT TRUCKS & VANS)

To save diagnostic time, ALWAYS check for blown fuses or fusible links before proceeding with diagnosis. If fuses are blown, locate and repair short circuit before replacing fuses. Ensure all related relay and wire harness connections are clean and tight. Repair as necessary. See WIRING DIAGRAMS.

NOTE: Vehicles may be equipped with a PCM using an Electronically Erasable Programmable Read Only Memory (EEPROM). When replacing PCM, the new PCM must be programmed.

2.2L: "S" & "T" SERIES

NOTE: For circuit, wire color and terminal identification, see WIRING DIAGRAMS. Also see WIRING DIAGRAMS in appropriate MANUAL or AUTOMATIC A/C HEATER SYSTEMS article.

Description

Regardless of selected A/C mode setting, a request is made to Powertrain Control Module (PCM)/Vehicle Control Module (VCM) to turn on A/C compressor. Request is made through A/C request signal circuit from HVAC control assembly. Power and ground are provided to HVAC control assembly by ignition voltage, ground circuits and splice pack.

In order for PCM/VCM to internally ground A/C clutch relay control circuit, request signal needs to be grounded. A 12-volt request signal is sent out over A/C request signal circuit and grounded through PCM/VCM when vehicle operator makes an A/C request. When this request signal is grounded, PCM/VCM can activate A/C compressor clutch.

PCM/VCM turns on A/C compressor by providing a path to ground through A/C clutch relay control circuit for A/C compressor clutch relay. Power is provided to A/C compressor clutch relay internally of underhood fuse block. Once relay closes its internal switch, power from battery is provided to A/C compressor clutch through A/C compressor clutch supply voltage circuit. Whenever compressor is turned off, A/C compressor clutch diode prevents a voltage spike from burning up compressor clutch coil. Ground circuit and underhood fuse block provides a path to ground for compressor. A/C clutch relay control circuit is grounded internally within the PCM/VCM.

A/C system is protected by A/C refrigerant pressure sensor. Sensors output to PCM/VCM is variable and is dependent upon pressure inside line. A higher pressure results in a higher voltage output. A/C pressure is constantly monitored in order to allow A/C compressor clutch to disengage as needed. If line pressures climbs greater than 410 psi (28.8 kg/cm²) or fall less than 30 psi (2.1 kg/cm²), PCM will turn off A/C compressor clutch. When high side pressures drop back down between 150–250 psi (10.5–17.6 kg/cm²), PCM/VCM will allow the A/C compressor to operate.

A/C clutch relay will remain de-energized when DTC P0530 is set, or if there is no A/C request signal due to an open A/C select switch circuit. For additional diagnosis, see appropriate MANUAL A/C-HEATER SYSTEMS article.

Diagnostic System Check

1) Install scan tool. If scan tool powers up, go to next step. If scan tool does not power up, see SCAN TOOL DOES NOT POWER UP in appropriate BODY CONTROL MODULES article.

2) Turn ignition on, engine off. Try to establish scan tool communication with Powertrain Control Module (PCM) on 2001 vehicles or HVAC control module on 2000 models. On all models, if communication with module is established, go to next step. If communication with module is not established, see SCAN TOOL DOES NOT COMMUNICATE WITH CLASS 2 DEVICE in appropriate BODY CONTROL MODULES article.

3) Select display DTC function for PCM. Record all displayed DTCs and status of displayed DTCs. If DTCs are displayed, go to next

step. If no DTCs are displayed, see COMPRESSOR CLUTCH DOES NOT ENGAGE or COMPRESSOR CLUTCH DOES NOT DISENGAGE.

4) If scan tool does not display DTCs beginning with "U", see appropriate SELF-DIAGNOSTICS article in ENGINE PERFORMANCE. If scan tool displays DTCs beginning with "U", see SCAN TOOL DOES NOT COMMUNICATE WITH CLASS 2 DEVICE in appropriate BODY CONTROL MODULES article.

Compressor Clutch Does Not Engage

1) If diagnostic system check has not been performed, see DIAGNOSTIC SYSTEM CHECK. If diagnostic system check has been performed, go to next step.

2) Ensure outside air temperature is greater than 38°F (3°C). Start engine. Turn blower motor switch to maximum speed position. Place mode switch in bi-level position. Place air temperature control switch in coldest position. If A/C compressor operates, problem is intermittent. If A/C compressor does not operate, go to next step.

3) Park vehicle inside or in shade. Open windows in order to ventilate interior of vehicle. If A/C system was operating, then allow A/C system to equalize for about 2 minutes. Turn ignition switch to OFF position. Install Refrigerant Station (J 43600 ACR 2000). Record outside air temperature at vehicle. Record readings of low and high side static pressures. Compare pressure values with specifications for ambient air temperature. See PRESSURE-TEMPERATURE RELATIONSHIP article in GENERAL SERVICING. If pressure values are within specification for ambient air temperature and within 15 psi (1.1 kg/cm²) of each other, go to next step. If pressure values are not within specification for ambient air temperature or within 15 psi (1.1 kg/cm²) of each other, see LEAK TESTING article in GENERAL SERVICING.

4) Turn ignition switch to ON position, with engine off. Using scan tool, observe A/C HIGH SIDE PRESSURE SENSOR parameter in POWERTRAIN data list. Compare A/C HIGH SIDE PRESSURE on scan tool to high side pressure value on refrigerant station. If high side pressure values are within 15 psi (1.1 kg/cm²) of each other, go to next step. If high side pressure values are not within 15 psi (1.1 kg/cm²) of each other, go to step 18).

5) If HVAC control assembly is inoperative, go to step 17). If HVAC control assembly is not inoperative, go to next step.

6) Start engine. Using scan tool, observe A/C REQUEST SIGNAL parameter in POWERTRAIN ENGINE 2 data list. Turn air temperature switch to coldest position. Place mode switch in BI-LEVEL position. If scan tool indicates A/C REQUEST SIGNAL parameter is YES, go to next step. If scan tool does not indicate A/C REQUEST SIGNAL parameter is YES, go to step 29).

7) Using scan tool, observe A/C REFRIGERANT PRESSURE SENSOR parameter in POWERTRAIN data list. If scan tool indicates A/C HIGH SIDE PRESSURE parameter is 45-425 psi (3.2-29.9 kg/cm²), go to step 11). If scan tool does not indicate A/C HIGH SIDE PRESSURE parameter is 45-425 psi (3.2-29.9 kg/cm²), go to next step.

8) Turn ignition switch to OFF position. Disconnect A/C refrigerant pressure sensor. Start engine. Using scan tool, observe A/C HIGH SIDE PRESSURE parameter. If scan tool indicates A/C HIGH SIDE PRESSURE parameter is greater than 425 psi (29.9 kg/cm²), go to next step. If scan tool does not indicate A/C HIGH SIDE PRESSURE parameter is greater than 425 psi (29.9 kg/cm²), go to step 22).

9) Turn ignition switch to OFF position. Connect fused jumper (3 amp) between signal circuit (Red/Black wire) and low reference circuit (Black wire) of A/C refrigerant pressure sensor. Start engine. Using scan tool, observe A/C HIGH SIDE PRESSURE parameter. If scan tool indicates A/C REFRIGERANT PRESSURE SENSOR parameter is less than 45 psi (3.2 kg/cm²), go to next step. If scan tool does not indicate A/C REFRIGERANT PRESSURE SENSOR parameter is less than 45 psi (3.2 kg/cm²), go to step 23).

10) Turn ignition switch to OFF position. Disconnect fused jumper wire. Connect fused jumper (3 amp) between 5-volt reference circuit (Gray wire) and signal circuit (Red/Black wire) of A/C refrigerant pressure sensor. Start engine. Using scan tool, observe A/C HIGH SIDE PRESSURE parameter. If scan tool indicates A/C REFRIGERANT PRESSURE SENSOR parameter is greater than 425 psi (29.9 kg/cm²), go to step 21). If scan tool does not indicate A/C REFRIGERANT PRESSURE SENSOR parameter is greater than 425 psi (29.9 kg/cm²), go to step 20).

11) Using scan tool, command A/C compressor clutch relay on and off. If A/C compressor clutch relay turns on and off with each command, go to step 15). If A/C compressor clutch relay does not turn on and off with each command, go to next step.

12) Turn ignition switch to OFF position. Disconnect A/C compressor clutch relay. Turn ignition switch to ON position, with engine off. Using test light connected to ground, probe coil side voltage supply circuit of A/C relay. If test light is on, go to next step. If test light is off, go to step 31).

13) Connect test light between control circuit (Dark Green/White wire) of A/C compressor clutch relay and coil side voltage supply circuit of A/C compressor clutch relay. Using scan tool, command A/C compressor clutch relay on and off. If test light turns on and off with each command, go to step 33). If test light does not turn on and off with each command, go to next step.

14) If test light remains on with each command, go to step 26). If test light does not remain on with each command, go to step 25).

15) Turn ignition switch to OFF position. Disconnect A/C compressor clutch relay. Using test light connected to ground, probe switch side voltage supply circuit of A/C compressor clutch relay. If test light is on, go to next step. If test light is off, go to step 30).

16) Connect fused jumper (10 amp) between switch side voltage circuit of A/C compressor clutch relay and A/C compressor clutch supply voltage circuit (Dark Green wire) of A/C compressor clutch. If A/C compressor clutch engages, go to step 33). If A/C compressor clutch does not engage, go to step 27).

17) Check ignition voltage circuit (Brown wire) of HVAC control assembly for short to ground, high resistance or open. If problem was found, repair as necessary. After repairs, go to step 44). If problem was not found, go to step 19).

18) Check ground circuit (Black wire) of A/C pressure sensor for open. If problem was found, repair as necessary. After repairs, go to step 44). If problem was not found, go to step 32).

19) Check ground circuit of HVAC control assembly for open. If problem was found, repair as necessary. After repairs, go to step 44). If problem was not found, go to step 36).

20) Check 5-volt reference circuit (Gray wire) of A/C refrigerant pressure sensor for short to ground. If problem was found, repair as necessary. After repairs, go to step 44). If problem was not found, go to step 37).

21) Check 5-volt reference circuit (Gray wire) of A/C refrigerant pressure sensor for short to voltage, high resistance or open. If problem was found, repair as necessary. After repairs, go to step 44). If problem was not found, go to step 34).

22) Check signal circuit (Red/Black wire) of A/C refrigerant pressure sensor for short to ground. If problem was found, repair as necessary. After repairs, go to step 44). If problem was not found, go to step 37).

23) Check signal circuit of A/C refrigerant pressure sensor for short to voltage, high resistance, or open. If problem was found, repair as necessary. After repairs, go to step 44). If problem was not found, go to next step.

24) Check low reference circuit (Black wire) of A/C refrigerant pressure sensor for high resistance or open. If problem was found, repair as necessary. After repairs, go to step 44). If problem was not found, go to step 37).

25) Check control circuit (Dark Green/White wire) of A/C compressor clutch relay for open. If problem was found, repair as necessary. After repairs, go to step 44). If problem was not found, go to step 37).

26) Check control circuit (Dark Green/White wire) of A/C compressor clutch relay for short to ground. If problem was found, repair as necessary. After repairs, go to step 44). If problem was not found, go to step 37).

27) Check A/C compressor clutch supply voltage circuit (Dark Green wire) of A/C compressor clutch for short to ground, high resistance, or open. If problem was found, repair as necessary. After repairs, go to step 44). If problem was not found, go to next step.

28) Check ground circuit (Black wire) of A/C compressor clutch for high resistance or open. If problem was found, repair as necessary. After repairs, go to step 44). If problem was not found, go to step 35).

29) Turn ignition switch to OFF position. Check A/C request signal circuit (Light Blue wire) for short to ground, high resistance, or open. If problem was found, repair as necessary. After repairs, go to step 44). If problem was not found, go to step 37).

30) Repair switch side voltage supply circuit of A/C compressor clutch relay. After repairs, go to step 44).

31) Repair coil side voltage supply circuit of A/C compressor clutch relay. After repairs, go to step 44).

32) Check A/C high pressure sensor connector for poor connections. If problem was found, repair as necessary. After repairs, go to step 44). If problem was not found, go to step 38).

33) Check A/C compressor clutch relay connector for poor connections. If problem was found, repair as necessary. After repairs, go to step 44). If problem was not found, go to step 40).

34) Check A/C refrigerant pressure sensor connector for poor connections. If problem was found, repair as necessary. After repairs, go to step 44). If problem was not found, go to step 39).

35) Check A/C compressor clutch connector for poor connections. If problem was found, repair as necessary. After repairs, go to step 44). If problem was not found, go to step 41).

36) Check HVAC control assembly connector for poor connections. If problem was found, repair as necessary. After repairs, go to step 44). If problem was not found, go to step 42).

37) Check PCM/VCM connectors for poor connections. If problem was found, repair as necessary. After repairs, go to step 44). If problem was not found, go to step 43).

38) Replace A/C high pressure switch. After repairs, go to step 44).

39) Replace A/C refrigerant pressure sensor. After repairs, go to step 44).

40) Replace A/C compressor clutch relay. After repairs, go to step 44).

41) Replace A/C compressor clutch coil. See appropriate COMPRESSOR SERVICING article in GENERAL SERVICING. After repairs, go to step 44).

42) Replace HVAC control assembly. See REMOVAL & INSTALLATION in appropriate MANUAL A/C-HEATER SYSTEMS article. After repairs, go to step 44).

43) Replace PCM/VCM. See appropriate REMOVAL, OVERHAUL & INSTALLATION article in ENGINE PERFORMANCE. After repairs, go to next step.

44) Operate system to verify repair.

Compressor Clutch Does Not Disengage

1) If diagnostic system check has not been performed, see DIAGNOSTIC SYSTEM CHECK. If diagnostic system check has been performed, go to next step.

2) Start engine. Turn blower motor switch to OFF position. Place mode switch in OFF position. If A/C compressor clutch engages, go to next step. If A/C compressor clutch does not engage, problem is intermittent.

3) Using scan tool, observe A/C REQUEST SIGNAL parameter in powertrain data list. If scan tool indicates A/C REQUEST SIGNAL parameter is YES, go to next step. If scan tool does not indicate A/C REQUEST SIGNAL parameter is YES, go to step 6).

4) Check A/C Request Signal circuit (Light Blue wire) for short to ground. If problem was found, repair as necessary. After repairs, go to step 17). If problem was not found, go to next step.

5) Turn ignition switch to OFF position. Disconnect PCM harness connector. Start engine. Using scan tool, observe A/C REQUEST SIGNAL parameter. If scan tool indicates A/C REQUEST parameter is YES, go to step 12). If scan tool does not indicate A/C REQUEST parameter is YES, go to step 11).

6) Remove A/C compressor clutch relay. If A/C compressor clutch turns off, go to next step. If A/C compressor clutch does not turn off, go to step 9).

7) Measure resistance between switch side of A/C compressor clutch relay terminals. If resistance is infinite, go to next step. If resistance is not infinite, go to step 10).

8) Check A/C compressor clutch relay control circuit (Dark Green/White wire) for short to ground. If problem was found, repair as necessary. After repairs, go to step 17). If problem was not found, go to step 12).

9) Check A/C compressor clutch supply voltage circuit (Dark Green wire) for short to voltage. If problem was found, repair as necessary. After repairs, go to step 17). If problem was not found, go to step 14).

10) Check A/C compressor clutch relay connector for poor connections. If problem was found, repair as necessary. After repairs, go to step 17). If problem was not found, go to step 13).

11) Check HVAC control assembly connector for poor connections. If problem was found, repair as necessary. After repairs, go to step 17). If problem was not found, go to step 15).

12) Check PCM/VCM connectors for poor connections. If problem was found, repair as necessary. After repairs, go to step 17). If problem was not found, go to step 16).

13) Replace A/C compressor clutch relay. After repairs, go to step 17).

14) Replace A/C compressor clutch. See appropriate COMPRESSOR SERVICING article in GENERAL SERVICING. After repairs, go to step 17).

15) Replace HVAC control assembly. See REMOVAL & INSTALLATION in appropriate MANUAL A/C-HEATER SYSTEMS article. After repairs, go to step 17).

16) Replace PCM/VCM. See appropriate REMOVAL, OVERHAUL & INSTALLATION article in ENGINE PERFORMANCE. After repairs, go to next step.

17) Operate system to verify repair.

3.4L: "A" & "B" SERIES

NOTE: For circuit, wire color and terminal identification, see WIRING DIAGRAMS. Also see WIRING DIAGRAMS in appropriate MANUAL or AUTOMATIC A/C HEATER SYSTEMS article.

Description

Powertrain Control Module (PCM) will operate A/C system

without any driver input. PCM will command A/C compressor clutch on to help reduce moisture inside vehicle. A/C compressor is on, even in cool weather conditions, to help eliminate moisture from fogging windshield. A/C LED will not illuminate unless driver presses A/C request switch on HVAC control module. Otherwise, A/C system may be running without A/C LED indicator illuminated.

Regardless of selected A/C mode setting, a request is made to PCM to turn on A/C compressor on class 2 serial data circuit. Request is made by HVAC control module to Body Control Module (BCM) through A/C request signal circuit when A/C switch grounds 12-volt signal from BCM. BCM then sends a class 2 message to PCM on BCM class 2 serial data circuit. PCM grounds clutch relay control circuit and engages A/C compressor clutch. Power is provided to HVAC control module by console junction block through ignition voltage, which is routed through splice pack and battery positive voltage circuits.

PCM turns on A/C compressor by providing a path to ground through A/C clutch relay control circuit for A/C compressor clutch relay. Power is provided to A/C compressor clutch relay internally through underhood junction block. Once relay closes its internal switch, power from battery is provided to A/C compressor clutch through A/C compressor clutch supply voltage circuit. Whenever compressor is turned off, A/C compressor clutch diode, located in underhood junction block, prevents a voltage spike from entering vehicles electrical system. ground circuit provides a path to ground for compressor and relay. A/C clutch relay control circuit is grounded internally within PCM.

BCM or PCM will shut off A/C compressor under extreme vehicle loads. If system voltage falls below 10 volts, an A/C command will not be given until voltage is raised to 10.5 volts. If coolant temperature rises greater than 259°F (126°C) or throttle is opened 95 percent or more, compressor clutch will be turned off.

A/C compressor clutch is protected from an overheating condition by an A/C compressor temperature switch mounted at rear of compressor. Switch is wired internally to compressor and is not serviceable. Switch shuts off compressor when temperatures reach 311°F (155°C) and allows clutch to engage again when temperatures fall to 257°F (125°C).

A/C system is protected by A/C refrigerant pressure sensor. Sensors' output to PCM is variable and is dependent upon pressure inside line. A higher pressure results in a higher voltage output. A/C pressure is constantly monitored in order to allow A/C compressor clutch to disengage as needed. If line pressures climb greater than 432 psi (30.4 kg/cm²), PCM will turn off A/C compressor clutch until pressure lowers to 219 psi (15.4 kg/cm²). If line pressures fall below 27 psi (1.9 kg/cm²), PCM will turn off A/C compressor clutch until pressure raises to 30 psi (2.1 kg/cm²).

A/C system is protected by evaporator temperature sensor. This sensor is mounted on evaporator core and provides HVAC control module with surface temperature of evaporator core. If evaporator temperature sensor reads a temperature of 32°F (0°C), HVAC control module will turn off A/C compressor clutch until evaporator temperatures reach 36°F (2°C).

Diagnostic System Check

- 1) Install scan tool. If scan tool powers up, go to next step. If scan tool does not power up, see SCAN TOOL DOES NOT POWER UP in appropriate BODY CONTROL MODULES article.

2) Turn ignition on, engine off. Try to establish scan tool communication with Powertrain Control Module (PCM). If communication with PCM is established, go to next step. If communication with PCM is not established, see SCAN TOOL DOES NOT COMMUNICATE WITH CLASS 2 DEVICE in appropriate BODY CONTROL MODULES article.

3) Select display DTC function for PCM. Record all displayed DTCs and status of displayed DTCs. If DTCs are displayed, go to next step. If no DTCs are displayed, see COMPRESSOR CLUTCH DOES NOT ENGAGE or COMPRESSOR CLUTCH DOES NOT DISENGAGE.

4) If scan tool does not display DTCs beginning with "U", see appropriate SELF-DIAGNOSTICS article in ENGINE PERFORMANCE. If scan tool displays DTCs beginning with "U", see SCAN TOOL DOES NOT COMMUNICATE WITH CLASS 2 DEVICE in appropriate BODY CONTROL MODULES article.

Compressor Clutch Does Not Engage

1) If diagnostic system check has not been performed, see DIAGNOSTIC SYSTEM CHECK. If diagnostic system check has been performed, go to next step.

2) Ensure outside air temperature is greater than 38°F (3°C). Start engine. Turn blower motor switch to maximum speed position. Place A/C request switch in ON position. Place air temperature control switch in coldest position. If A/C compressor operates, problem is intermittent. If A/C compressor does not operate, go to next step.

3) Park vehicle inside or in shade. Open windows in order to ventilate interior of vehicle. If A/C system was operating, then allow A/C system to equalize for about 2 minutes. Turn ignition switch to OFF position. Install Refrigerant Station (J 43600 ACR 2000). Record outside air temperature at vehicle. Record readings of low and high side static pressures. Compare pressure values with specifications for ambient air temperature. See PRESSURE-TEMPERATURE RELATIONSHIP article in GENERAL SERVICING. If pressure values are within specification for ambient air temperature and within 15 psi (1.1 kg/cm²) of each other, go to next step. If pressure values are not within specification for ambient air temperature or within 15 psi (1.1 kg/cm²) of each other, see LEAK TESTING article in GENERAL SERVICING.

4) Turn ignition switch to ON position, with engine off. Using scan tool, observe A/C HIGH SIDE PRESSURE SENSOR parameter in POWERTRAIN data list. Compare A/C HIGH SIDE PRESSURE on scan tool to high side pressure value on refrigerant station. If high side pressure values are within 15 psi (1.1 kg/cm²) of each other, go to next step. If high side pressure values are not within 15 psi (1.1 kg/cm²) of each other, go to step 23).

5) If HVAC control module is inoperative, go to step 18). If HVAC control module is not inoperative, go to next step.

6) Start engine. Using scan tool, observe A/C REQUEST SIGNAL parameter in POWERTRAIN data list. Place air temperature switch in coldest position. Place A/C request switch in ON position. If scan tool indicates A/C REQUEST SIGNAL parameter is YES, go to step 12). If scan tool does not indicate A/C REQUEST SIGNAL parameter is YES, go to next step.

7) If A/C request indicator is on, go to next step. If A/C request indicator is not on, go to step 32).

8) Turn ignition switch to OFF position. Check A/C request signal circuit (Dark Green/White wire) for short to ground, high resistance, or open. If problem was found, repair as necessary. After repairs, go to step 40). If problem was not found, go to next step.

9) Disconnect evaporator temperature sensor. Measure resistance of evaporator temperature sensor. See EVAPORATOR TEMPERATURE SENSOR RESISTANCE table. If resistance is near values specified in sensor resistance table, go to next step. If resistance is not near values specified in sensor resistance table, go to step 30).

10) Check evaporator temperature signal circuit (Gray wire) for short to ground, high resistance, or open. If problem was found, repair as necessary. After repairs, go to step 40). If problem was not found, go to next step.

11) Check low reference circuit (Black wire) for short to ground, high resistance, or open. If problem was found, repair as necessary. After repairs, go to step 40). If problem was not found, go to step 27).

12) Using scan tool, command A/C compressor clutch relay on and off. If A/C compressor clutch relay turns on and off with each command, go to step 16). If A/C compressor clutch relay does not turn on and off, go to next step.

13) Turn ignition switch to OFF position. Disconnect A/C compressor clutch relay. Turn ignition switch to ON position, with engine off. Using test light connected to ground, probe coil side voltage supply circuit of A/C compressor clutch relay. If test light is on, go to next step. If test light is off, go to step 26).

14) Connect test light between control circuit (Dark Green/White wire) of A/C compressor clutch relay and coil side voltage supply circuit of A/C compressor clutch relay. Using scan tool, command A/C compressor clutch relay on and off. If test light turns on and off with each command, go to step 29). If test light does not turn on and off with each command, go to next step.

15) If test light remains on with each command, go to step 21). If test light does not remain on with each command, go to step 20).

16) Turn ignition switch to OFF position. Disconnect A/C compressor clutch relay. Using test light connected to ground, probe switch side voltage supply circuit of A/C compressor clutch relay. If test light is on, go to next step. If test light is off, go to step 25).

17) Connect fused jumper (10 amp) between switch side voltage circuit of A/C compressor clutch relay and A/C compressor clutch supply voltage circuit (Dark Green wire) of A/C compressor clutch. Turn ignition switch to ON position, with engine off. If A/C compressor clutch engages, go to step 29). If A/C compressor clutch does not engage, go to step 22).

18) Check ignition voltage circuit (Brown wire) of HVAC control module for short to ground, high resistance, or open. If problem was found, repair as necessary. After repairs, go to step 40). If problem was not found, go to next step.

19) Check ground circuit (Black wire) of HVAC control module for open. If problem was found, repair as necessary. After repairs, go to step 40). If problem was not found, go to step 32).

20) Check control circuit (Dark Green/White wire) of A/C compressor clutch relay for open. If problem was found, repair as necessary. After repairs, go to step 40). If problem was not found, go to step 33).

21) Check control circuit (Dark Green/White wire) of A/C compressor clutch relay for short to ground. If problem was found, repair as necessary. After repairs, go to step 40). If problem was not found, go to step 33).

22) Check A/C compressor clutch supply voltage circuit (Dark Green wire) at A/C compressor clutch for short to ground, high resistance, or open. If problem was found, repair as necessary. After repairs, go to step 40). If problem was not found, go to step 24).

23) Check ground circuit (Black wire) of A/C pressure sensor for open. If problem was found, repair as necessary. After repairs, go to step 40). If problem was not found, go to step 28).

24) Check ground circuit (Black wire) of A/C compressor clutch for high resistance or open. If problem was found, repair as necessary. After repairs, go to step 40). If problem was not found, go to step 31).

- 25) Repair switch side voltage supply circuit of A/C compressor clutch relay. After repairs, go to step 40).
- 26) Repair coil side voltage supply circuit of A/C compressor clutch relay. After repairs, go to step 40).
- 27) Check off blower motor control circuit (Dark Green wire) for short to voltage. If problem was found, repair as necessary. After repairs, go to step 40). If problem was not found, go to step 32).
- 28) Check A/C high pressure sensor connector for poor connections. If problem was found, repair as necessary. After repairs, go to step 40). If problem was not found, go to step 34).
- 29) Check A/C compressor clutch relay connector for poor connections. If problem was found, repair as necessary. After repairs, go to step 40). If problem was not found, go to step 36).
- 30) Check evaporator temperature sensor for poor connections. If problem was found, repair as necessary. After repairs, go to step 40). If problem was not found, go to step 35).
- 31) Check A/C compressor clutch connector for poor connections. If problem was found, repair as necessary. After repairs, go to step 40). If problem was not found, go to step 37).
- 32) Check HVAC control module connector for poor connections. If problem was found, repair as necessary. After repairs, go to step 40). If problem was not found, go to step 38).
- 33) Check PCM connectors for poor connections. If problem was found, repair as necessary. After repairs, go to step 40). If problem was not found, go to step 39).
- 34) Replace A/C high pressure switch. After repairs, go to step 40).
- 35) Replace evaporator temperature sensor. See REMOVAL & INSTALLATION in appropriate MANUAL A/C-HEATER SYSTEMS article. After repairs, go to step 40).
- 36) Replace A/C compressor clutch relay. After repairs, go to step 40).
- 37) Replace the A/C compressor clutch coil. See appropriate COMPRESSOR SERVICING article in GENERAL SERVICING. After repairs, go to step 40).
- 38) Replace the HVAC control module. See REMOVAL & INSTALLATION in appropriate MANUAL A/C-HEATER SYSTEMS article. After repairs, go to step 40).
- 39) Replace PCM. See appropriate REMOVAL, OVERHAUL & INSTALLATION article in ENGINE PERFORMANCE. After repairs, go to next step.
- 40) Operate system to verify repair.

EVAPORATOR TEMPERATURE SENSOR RESISTANCE

Temp. - °F (°C)	Resistance (K/Ohms)
-22 (-30)	52.8
-2 (-20)	30.4
14 (-10)	18.0
32 (0)	11.4
50 (10)	7.3
68 (20)	4.9
86 (30)	3.3
104 (40)	2.3
122 (50)	1.9

Compressor Clutch Does Not Disengage

- 1) If diagnostic system check has not been performed, see DIAGNOSTIC SYSTEM CHECK. If diagnostic system check has been performed, go to next step.
- 2) Start engine. Turn blower motor switch to OFF position.

Place A/C request switch in OFF position. If A/C compressor operates, go to next step. If A/C compressor does not operate, problem is intermittent.

3) Using scan tool, observe A/C REQUEST SIGNAL parameter in POWERTRAIN data list. If scan tool indicates A/C REQUEST SIGNAL parameter is YES, go to next step. If scan tool does not indicate A/C REQUEST SIGNAL parameter is YES, go to step 6).

4) Check A/C request signal circuit (Dark Green/White wire) for short to ground. If problem was found, repair as necessary. After repairs, go to step 18). If problem was not found, go to next step.

5) Turn ignition switch to OFF position. Disconnect A/C high pressure switch. Start engine. Using scan tool, observe A/C REQUEST SIGNAL parameter. If scan tool indicates A/C REQUEST SIGNAL parameter is YES, go to step 13). If scan tool does not indicate A/C REQUEST SIGNAL parameter is YES, go to step 12).

6) Using scan tool, command A/C compressor clutch relay on and off. If A/C compressor clutch relay turns on and off with each command, go to next step. If A/C compressor clutch relay does not turn on and off with each command, go to step 9).

7) Remove A/C compressor clutch relay. If A/C compressor is on, go to step 10). If A/C compressor is not on, go to next step.

8) Measure resistance between switch side A/C compressor clutch relay terminals. If resistance infinite, go to next step. If resistance is not infinite, go to step 11).

9) Check A/C clutch relay control circuit (Dark Green/White wire) for short to ground. If problem was found, repair as necessary. After repairs, go to step 18). If problem was not found, go to step 13).

10) Check A/C compressor clutch supply voltage circuit (Dark Green wire) for short to voltage. If problem was found, repair as necessary. After repairs, go to step 18). If problem was not found, go to step 15).

11) Check A/C compressor clutch relay connector for poor connections. If problem was found, repair as necessary. After repairs, go to step 18). If problem was not found, go to step 14).

12) Check HVAC control module connector for poor connections. If problem was found, repair as necessary. After repairs, go to step 18). If problem was not found, go to step 16).

13) Check PCM connectors for poor connections. If problem was found, repair as necessary. After repairs, go to step 18). If problem was not found, go to step 17).

14) Replace A/C compressor clutch relay. After repairs, go to step 18).

15) Replace A/C compressor clutch. See appropriate COMPRESSOR SERVICING article in GENERAL SERVICING. After repairs, go to step 18).

16) Replace HVAC control module. See REMOVAL & INSTALLATION in appropriate MANUAL A/C-HEATER SYSTEMS article. After repairs, go to step 18).

17) Replace PCM. See appropriate REMOVAL, OVERHAUL & INSTALLATION article in ENGINE PERFORMANCE. After repairs, go to next step.

18) Operate system to verify repair.

3.4L: "U" SERIES (2000)

NOTE: For circuit, wire color and terminal identification, see WIRING DIAGRAMS. Also see WIRING DIAGRAMS in appropriate MANUAL or AUTOMATIC A/C HEATER SYSTEMS article.

Description

Compressor for air conditioning system is belt-driven by engine through A/C compressor clutch. Clutch allows compressor to perform the following functions:

- * Engage for A/C and defroster operation.
- * Disengage when air conditioning is not requested.
- * Disengage when engine load must be reduced.

Battery voltage is supplied to Powertrain Control Module (PCM) when A/C control is activated or when A/C-heater control mode selector is placed in any of the following modes: MAX A/C, NORM A/C, BI-LEVEL, DEFOG or DEFROST. Voltage signal tells PCM that A/C compressor operation is requested. Under normal operating conditions, PCM supplies a ground to relay coil of A/C CLU relay, relay energizes, voltage is supplied to A/C compressor clutch coil through relay center fuse, A/C compressor clutch coil engages and compressor runs.

If PCM determines engine load should be reduced, such as during full throttle conditions, PCM de-energizes A/C CLU relay in order to disengage compressor clutch coil. De-energization occurs even though voltage signal from A/C-heater control is still present at PCM.

A/C CLU diode provides a path for high current that results from voltage spikes generated from collapsing magnetic field of A/C compressor clutch coil. Voltage spikes occur every time coil de-energizes.

Diagnostic System Check

- 1) Install scan tool. If scan tool powers up, go to next step. If scan tool does not power up, see SCAN TOOL DOES NOT POWER UP in appropriate BODY CONTROL MODULES article.
- 2) Turn ignition on, engine off. Try to establish scan tool communication with Body Control Module (BCM) and Powertrain Control Module (PCM). If communication with all modules is established, go to next step. If communication with all modules is not established, see SCAN TOOL DOES NOT COMMUNICATE WITH CLASS 2 DEVICE in appropriate BODY CONTROL MODULES article.
- 3) Select display DTC function for each module. Record all displayed DTCs, status of displayed DTCs and which module set DTCs. If DTCs are displayed, go to next step. If no DTCs are displayed, see COMPRESSOR CLUTCH DOES NOT ENGAGE or COMPRESSOR CLUTCH DOES NOT DISENGAGE.
- 4) If scan tool displays DTCs beginning with "B", see appropriate SELF-DIAGNOSTICS article in BODY CONTROL MODULES. If scan tool displays DTCs beginning with "P", see appropriate SELF-DIAGNOSTICS article in ENGINE PERFORMANCE. If scan tool displays DTCs beginning with "U", see SCAN TOOL DOES NOT COMMUNICATE WITH CLASS 2 DEVICE in appropriate BODY CONTROL MODULES article.

Compressor Clutch Does Not Engage

- 1) If diagnostic system check has not been performed, see DIAGNOSTIC SYSTEM CHECK. If diagnostic system check has been performed, go to next step.
- 2) Turn ignition switch to OFF position. Install both high and low A/C freon pressure gages. Read freon pressure with engine off. Freon pressure in high and low sides should equal each other after A/C system has come to rest. Freon pressure will fluctuate depending on ambient temperature. Proper clutch operation depends on correct refrigerant charge, low freon charge will shut off A/C compressor operation. If high and low side freon pressures are below 50 psi (3.5 kg/cm²), see LEAK TESTING article in GENERAL SERVICING. If high and low side freon pressures are not below 50 psi (3.5 kg/cm²), go to next step.
- 3) If high and low side freon pressures is greater than 100 psi (7.0 kg/cm²), go to next step. If high and low side freon pressures are not greater than 100 psi (7.0 kg/cm²), go to step 5).

4) Evacuate and recharge A/C system according to proper freon fill specifications. See appropriate GENERAL SERVICING PROCEDURES articles. After repairs, go to step 23).

5) Check A/C compressor clutch supply voltage circuit (Dark Green wire) for a short to ground. If problem was found, repair as necessary. After repairs, go to step 23). If problem was not found go to next step.

6) Remove A/C CLU relay from underhood accessory wiring junction block. Disconnect A/C compressor clutch coil connector. Connect fused jumper (10 amp) between ignition feed terminal for switch side of A/C CLU relay and A/C compressor clutch supply voltage circuit (Dark Green wire) at A/C CLU relay. Connect DVOM between A/C compressor clutch coil connector terminal "B" (Dark Green wire) and ground. Turn ignition switch to ON position. Measure available voltage at A/C compressor clutch coil connector terminal "B". If battery voltage is present, go to step 8). If battery voltage is not present, go to next step.

7) Repair poor connection or open in A/C compressor voltage supply circuit (Dark Green wire). After repairs, go to step 23).

8) Using DVOM, measure resistance between terminal "A" (Black wire) of A/C compressor clutch coil connector and ground. If resistance is 0-2 ohms, go to step 10). If resistance is not 0-2 ohms, go to next step.

9) Repair poor connection or open in A/C compressor clutch ground circuit (Black wire). After repairs, go to step 23).

10) Disconnect PCM connector C2. Reinstall A/C CLU relay. Connect fused jumper (10 amp) between A/C CLU relay control circuit (Dark Green/White wire) at PCM connector C2 and ground. Turn ignition switch to ON position. Using DVOM, measure voltage between A/C compressor clutch voltage supply circuit (Dark Green wire) and ground. If battery voltage is present, go to next step. If battery voltage is not present, go to step 12).

11) Remove fused jumper between PCM connector C2 and ground. Reconnect A/C compressor clutch coil connector. Reinstall fused jumper between A/C CLU relay control circuit (Dark Green/White wire) at PCM connector C2 and ground. Turn ignition on. If A/C compressor clutch engages, see TESTING under appropriate MANUAL A/C-HEATER SYSTEMS article. If A/C compressor clutch does not engage, go to step 22).

12) Turn ignition switch to OFF position. Remove A/C CLU relay. Using DVOM, measure resistance of Dark Green/White wire between PCM connector C2 and underhood accessory wiring junction block connector C1. If resistance is 0-2 ohms, go to step 14). If resistance is not 0-2 ohms, go to next step.

13) Repair poor connection or open in Dark Green/White wire between PCM connector C2 and underhood accessory wiring junction block connector C1. After repairs, go to step 23).

14) Replace A/C CLU relay and retest A/C system. If problem has been corrected, go to step 23). If problem has not been corrected, go to next step.

15) Disconnect A/C-heater control connector C2. Using DVOM, measure resistance in Dark Green/White wire between PCM connector C2 and A/C-heater control connector C2. If resistance is 0-2 ohms, go to step 17). If resistance is not 0-2 ohms, go to next step.

16) Repair poor connection or open in Dark Green/White wire between PCM connector C2 and A/C-heater control connector C2. After repairs, go to step 23).

17) Using DVOM, check continuity between Dark Green/White wire at PCM connector C2 and ground. If continuity exists, go to next step. If continuity does not exist, go to step 19).

18) Repair short to ground in Dark Green/White wire between Dark Green/White wire at PCM connector C2 and ground. After repairs, go to step 23).

19) Disconnect DVOM. Reconnect all connectors back to their

respective modules. Install scan tool to diagnostic link connector. Start engine and allow to idle in park. Select area of scan tool which will read HVAC button output status. Depress A/C button on and off several times. If scan tool reads A/C REQUEST being sent by HVAC control head, go to next step. If scan tool does not read A/C REQUEST being sent by HVAC control head, go to step 21).

20) Check PCM and underhood accessory wiring junction block connectors for poor connections. If problem was found, repair as necessary. If problem was not found, replace PCM. See appropriate REMOVAL, OVERHAUL & INSTALLATION article in ENGINE PERFORMANCE. After repairs, go to step 23).

21) Replace A/C-heater control. See REMOVAL & INSTALLATION in appropriate MANUAL A/C-HEATER SYSTEMS article. After repairs, go to step 23).

22) Replace A/C compressor clutch coil. See appropriate COMPRESSOR SERVICING article in GENERAL SERVICING. After repairs, go to next step.

23) Operate system to verify repair.

Compressor Clutch Does Not Disengage

1) If diagnostic system check has not been performed, see DIAGNOSTIC SYSTEM CHECK. If diagnostic system check has been performed, go to next step.

2) Disconnect PCM connector C2. Turn ignition switch to ON position. If A/C compressor clutch disengages, go to next step. If A/C compressor clutch does not disengage, go to step 4).

3) Replace PCM. See appropriate REMOVAL, OVERHAUL & INSTALLATION article in ENGINE PERFORMANCE. After repairs, go to step 11).

4) Disconnect A/C CLU relay from underhood accessory wiring junction block. Turn ignition switch to ON position. If A/C compressor clutch disengages, go to next step. If A/C compressor clutch does not disengage, go to step 8).

5) Turn ignition switch to OFF position. Using DVOM, check continuity between PCM connector C2 terminal No. 39 (Dark Green/White wire) and ground. If continuity exists, go to next step. If continuity does not exist, go to step 7).

6) Repair short to ground in Dark Green/White wire between underhood accessory wiring junction block and PCM connector. After repairs, go to step 11).

7) Replace A/C CLU relay. After repairs, go to step 11).

8) Disconnect A/C compressor clutch coil connector. Using DVOM, measure voltage between A/C compressor clutch coil connector terminal "B" (Dark Green wire) and ground. Turn ignition switch to ON position. If battery voltage is present, go to next step. If battery voltage is not present, go to step 10).

9) Repair short to battery voltage in Dark Green wire between underhood accessory wiring junction block and A/C compressor clutch coil. After repairs, go to step 11).

10) Replace A/C compressor clutch coil. See appropriate COMPRESSOR SERVICING article in GENERAL SERVICING. After repairs, go to next step.

11) Turn ignition switch to OFF position. Reconnect all connectors/components disconnected. Operate system to verify repair.

Diagnostic Aids

Check for poor harness connections at PCM and A/C-heater control panel. Inspect for corrosion, backed-out terminal pins, and broken wires inside insulation. Check for damaged wire harness. If harness and connections are okay, disconnect PCM harness connectors. Connect a DVOM between ground and A/C clutch relay control circuit at PCM harness connector. Turn ignition switch to ON position. Observe DVOM while wiggling harness and connectors. A change in voltage

indicates location of fault.

3.4L: "U" SERIES (2001)

NOTE: For circuit, wire color and terminal identification, see WIRING DIAGRAMS. Also see WIRING DIAGRAMS in appropriate MANUAL or AUTOMATIC A/C HEATER SYSTEMS article.

Description

Powertrain Control Module (PCM) will operate A/C system without any driver input. PCM will command A/C compressor clutch on to help reduce moisture inside vehicle. A/C compressor is on, even in cool weather conditions, to help eliminate moisture from fogging windshield. A/C LED will not illuminate unless driver presses A/C request switch on HVAC control module. Otherwise, A/C system may be running without A/C LED indicator illuminated.

Regardless of selected A/C mode setting, a request is made to PCM to turn on A/C compressor. Request is made by HVAC control module to PCM through A/C request signal circuit when A/C switch grounds 12 volt signal from PCM. PCM turns on A/C compressor by providing a path to ground through A/C clutch relay control circuit for A/C compressor clutch relay. Power is provided to A/C compressor clutch relay internally of underhood junction block. Once relay closes its internal switch, power from battery is provided to A/C compressor clutch through A/C compressor clutch supply voltage circuit. Whenever compressor is turned off, A/C compressor clutch diode, located in underhood junction block, provides a path for voltage spike resulting from collapsing magnetic field of compressor clutch coil. Ground circuit provides a path to ground for compressor and relay. A/C clutch relay control circuit is grounded internally within PCM.

PCM will shut off A/C compressor under extreme vehicle loads, such as wide open throttle. PCM will shut off A/C compressor under extreme vehicle loads. If system voltage falls below 10 volts, an A/C command will not be given until voltage is raised to 10.8 volts. If coolant temperature rises greater than 259°F (126°C) or throttle is opened 95% or more, compressor clutch will be turned off. Compressor operation will be allowed when throttle is backed off to 90%.

A/C compressor clutch is protected from an overheating condition by an A/C compressor temperature switch mounted at rear of compressor. Switch is wired internally to compressor and is not serviceable. Switch shuts off compressor when temperatures reach 311°F (155°C) and allows clutch to engage again when temperatures fall to 257°F (125°C).

A/C system is protected by A/C refrigerant pressure sensor. Sensors output to PCM is variable and is dependent upon pressure inside line. A higher pressure results in a higher voltage output. A/C pressure is constantly monitored in order to allow A/C compressor clutch to disengage as needed. If line pressures climb greater than 432 psi (30.4 kg/cm²), PCM will turn off A/C compressor clutch until pressure lowers to 235 psi (16.5 kg/cm²). If line pressures fall below 26 psi (1.8 kg/cm²), PCM will turn off A/C compressor clutch until pressure raises to 30 psi (2.1 kg/cm²). A 5 volt reference signal is sent out over 5 volt reference circuit, from PCM, to A/C refrigerant pressure sensor. PCM monitors A/C pressure by monitoring voltage drop in sensor on A/C pressure sensor signal circuit. This circuit is how PCM monitors HVAC pressures. Ground for A/C refrigerant pressure sensor is provided by low reference circuit.

A/C system is protected by evaporator temperature sensor.

This sensor is mounted on evaporator core and provides HVAC control module with surface temperature of evaporator core. If evaporator temperature sensor reads a temperature of 32°F (0°C), HVAC control module will turn off A/C compressor clutch until evaporator temperatures reach 36°F (2°C). HVAC control module sends out a 5 volt reference signal to evaporator temperature sensor over 5 volt reference circuit. A thermistor varies reference voltage back to HVAC control module through low reference circuit.

Diagnostic System Check

- 1) Install scan tool. If scan tool powers up, go to next step. If scan tool does not power up, see SCAN TOOL DOES NOT POWER UP in appropriate BODY CONTROL MODULES article.
- 2) Turn ignition on, engine off. Try to establish scan tool communication with Powertrain Control Module (PCM). If communication with PCM is established, go to next step. If communication with PCM is not established, see SCAN TOOL DOES NOT COMMUNICATE WITH CLASS 2 DEVICE in appropriate BODY CONTROL MODULES article.
- 3) Select display DTC function for PCM. Record all displayed DTCs and status of displayed DTCs. If DTCs are displayed, go to next step. If no DTCs are displayed, see COMPRESSOR CLUTCH DOES NOT ENGAGE or COMPRESSOR CLUTCH DOES NOT DISENGAGE.
- 4) If scan tool does not display DTCs beginning with "U", see appropriate SELF-DIAGNOSTICS article in ENGINE PERFORMANCE. If scan tool displays DTCs beginning with "U", see SCAN TOOL DOES NOT COMMUNICATE WITH CLASS 2 DEVICE in appropriate BODY CONTROL MODULES article.

Compressor Clutch Does Not Engage

- 1) If diagnostic system check has not been performed, see DIAGNOSTIC SYSTEM CHECK. If diagnostic system check has been performed, go to next step.
- 2) Ensure outside air temperature is greater than 38°F (3°C). Start engine. Turn blower motor switch to maximum speed position. Place A/C request switch in ON position. Place air temperature control switch in coldest position. If A/C compressor operates, problem is intermittent. If A/C compressor does not operate, go to next step.
- 3) Park vehicle inside or in shade. Open windows in order to ventilate interior of vehicle. If A/C system was operating, then allow A/C system to equalize for about 2 minutes. Turn ignition switch to OFF position. Install Refrigerant Station (J 43600 ACR 2000). Record outside air temperature at vehicle. Record readings of low and high side static pressures. Compare pressure values with specifications for ambient air temperature. See PRESSURE-TEMPERATURE RELATIONSHIP article in GENERAL SERVICING. If pressure values are within specification for ambient air temperature and within 15 psi (1.1 kg/cm²) of each other, go to next step. If pressure values are not within specification for ambient air temperature or within 15 psi (1.1 kg/cm²) of each other, see LEAK TESTING article in GENERAL SERVICING.
- 4) Turn ignition switch to ON position, with engine off. Using scan tool, observe A/C HIGH SIDE PRESSURE SENSOR parameter in POWERTRAIN data list. Compare A/C HIGH SIDE PRESSURE on scan tool to high side pressure value on refrigerant station. If high side pressure values are within 15 psi (1.1 kg/cm²) of each other, go to next step. If high side pressure values are not within 15 psi (1.1 kg/cm²) of each other, go to step 20).
- 5) If HVAC control assembly is inoperative, go to step 19). If HVAC control assembly is not inoperative, go to next step.
- 6) Start engine. Using scan tool, observe A/C REQUEST SIGNAL parameter in POWERTRAIN engine data list. Place air temperature switch in coldest position. Turn blower motor to on position. Place A/C request switch in ON position. If scan tool indicates A/C REQUEST parameter is YES, go to step 13). If scan tool does not indicate A/C

REQUEST parameter is YES, go to next step.

7) If A/C request indicator is on, go to step 9). If A/C request indicator is not on, go to next step.

8) Ensure blower motor is in ON position. Turn ignition switch to ON position. Check OFF blower motor control circuit (Dark Green wire) at HVAC control module for short to voltage. If problem was found, repair as necessary. After repairs, go to step 40). If problem was not found, go to step 32).

9) Turn ignition switch to OFF position. Check A/C request signal circuit (Dark Green/White wire) for short to ground, high resistance or open. If problem was found, repair as necessary. After repairs, go to step 40). If problem was not found, go to next step.

10) Disconnect evaporator temperature sensor. Measure resistance of evaporator temperature sensor. See EVAPORATOR TEMPERATURE SENSOR RESISTANCE table under 3.4L: "A" & "B" SERIES. If resistance measures near value specified in sensor resistance table, go to next step. If resistance does not measure near value specified in sensor resistance table, go to step 30).

11) Check evaporator temperature sensor signal circuit (White wire) for short to ground, high resistance or open. If problem was found, repair as necessary. After repairs, go to step 40). If problem was not found, go to next step.

12) Check evaporator temperature sensor low reference circuit (Black wire) for short to ground, high resistance, or open. If problem was found, repair as necessary. After repairs, go to step 40). If problem was not found, go to step 32).

13) Using scan tool, command A/C compressor clutch relay on and off. If A/C compressor clutch relay turns on and off with each command, go to step 17). If A/C compressor clutch relay does not turn on and off with each command, go to next step.

14) Turn ignition switch to OFF position. Disconnect A/C compressor clutch relay. Turn ignition switch to ON position, with engine off. Using test light connected to ground, probe coil side voltage supply circuit of A/C compressor clutch relay. If test light is on, go to next step. If test light is off, go to step 27).

15) Connect test light between control circuit (Dark Green/White wire) of A/C compressor clutch relay and coil side voltage supply circuit of A/C compressor clutch relay. Using scan tool, command A/C compressor clutch relay on and off. If test light turns on and off with each command, go to step 27). If test light does not turn on and off with each command, go to next step.

16) If test light remains on with each command, go to step 23). If test light does not remain on with each command, go to step 22).

17) Turn ignition switch to OFF position. Disconnect A/C compressor clutch relay. Using test light connected to ground, probe switch side voltage supply circuit of A/C compressor clutch relay. If test light is on, go to next step. If test light is off, go to step 26).

18) Connect fused jumper (10 amp) between switch side voltage circuit of A/C compressor clutch relay and A/C compressor clutch supply voltage circuit (Dark Green wire) of A/C compressor clutch. Turn ignition switch to ON position, with engine off. If A/C compressor clutch engages, go to step 29). If A/C compressor clutch does not engage, go to step 24).

19) Check voltage supply circuits (Brown wires and Orange wire) to HVAC control assembly for short to ground, high resistance or open. If problem was found, repair as necessary. After repairs, go to step 40). If problem is not found, go to step 21).

20) Check ground circuit (Black wire) of A/C pressure sensor for open. If problem was found, repair as necessary. After repairs, go to step 40). If problem is not found, go to step 28).

21) Check ground circuit (Black wire) of HVAC control

assembly for open. If problem was found, repair as necessary. After repairs, go to step 40). If problem is not found, go to step 32).

22) Check control circuit (Dark Green/White wire) of A/C compressor clutch relay for open. If problem was found, repair as necessary. After repairs, go to step 40). If problem is not found, go to step 33).

23) Check control circuit (Dark Green/White wire) of A/C compressor clutch relay for short to ground. If problem was found, repair as necessary. After repairs, go to step 40). If problem is not found, go to step 33).

24) Check A/C compressor clutch supply voltage circuit (Dark Green wire) at A/C compressor clutch for short to ground, high resistance or open. If problem was found, repair as necessary. After repairs, go to step 40). If problem is not found, go to next step.

25) Check ground circuit (Black wire) of A/C compressor clutch for high resistance or open. If problem was found, repair as necessary. After repairs, go to step 40). If problem is not found, go to step 31).

26) Repair switch side voltage supply circuit of A/C compressor clutch relay. After repairs, go to step 40).

27) Repair coil side voltage supply circuit of A/C compressor clutch relay. After repairs, go to step 40).

28) Check A/C high pressure sensor connector for poor connections. If problem was found, repair as necessary. After repairs, go to step 40). If problem is not found, go to step 34).

29) Check A/C compressor clutch relay connector for poor connections. If problem was found, repair as necessary. After repairs, go to step 40). If problem is not found, go to step 36).

30) Check evaporator temperature sensor connector for poor connections. If problem was found, repair as necessary. After repairs, go to step 40). If problem is not found, go to step 35).

31) Check A/C compressor clutch connector for poor connections. If problem was found, repair as necessary. After repairs, go to step 40). If problem is not found, go to step 37).

32) Check HVAC control module connector for poor connections. If problem was found, repair as necessary. After repairs, go to step 40). If problem is not found, go to step 38).

33) Check PCM connectors for poor connections. If problem was found, repair as necessary. After repairs, go to step 40). If problem is not found, go to step 39).

34) Replace A/C high pressure switch. After repairs, go to step 40).

35) Replace evaporator temperature sensor. See REMOVAL & INSTALLATION in appropriate MANUAL A/C-HEATER SYSTEMS article. After repairs, go to step 40).

36) Replace A/C compressor clutch relay. After repairs, go to step 40).

37) Replace A/C compressor. See REMOVAL & INSTALLATION in appropriate MANUAL A/C-HEATER SYSTEMS article. After repairs, go to step 40).

38) Replace HVAC control module. See REMOVAL & INSTALLATION in appropriate MANUAL A/C-HEATER SYSTEMS article. After repairs, go to step 40).

39) Replace PCM. See appropriate REMOVAL, OVERHAUL & INSTALLATION article in ENGINE PERFORMANCE. After repairs, go to next step.

40) Operate system to verify repair.

Compressor Clutch Does Not Disengage

1) If diagnostic system check has not been performed, see DIAGNOSTIC SYSTEM CHECK. If diagnostic system check has been performed, go to next step.

2) Start engine. Place blower motor switch in OFF position.

Place A/C request switch in OFF position. If A/C compressor operates, go to next step. If A/C compressor does not operate, problem is intermittent.

3) Using scan tool, observe A/C REQUEST SIGNAL parameter in POWERTRAIN ENGINE data list. If scan tool indicates A/C REQUEST SIGNAL parameter is YES, go to next step. If scan tool does not indicate A/C REQUEST SIGNAL parameter is YES, go to step 6).

4) Check A/C request signal circuit (Dark Green/White wire) for short to voltage. If problem was found, repair as necessary. After repairs, go to step 17). If problem was not found, go to next step.

5) Turn ignition switch to OFF position. Disconnect HVAC control module connector. Back out terminal for A/C request signal circuit (Dark Green/White wire) from HVAC control head. Reconnect HVAC control module connector. Start engine. Using scan tool, observe A/C REQUEST SIGNAL parameter. If scan tool indicates A/C REQUEST SIGNAL parameter is YES, go to step 12). If scan tool does not indicate A/C REQUEST SIGNAL parameter is YES, go to step 11).

6) Remove A/C compressor clutch relay. If A/C compressor clutch turns off, go to next step. If A/C compressor clutch does not turn off, go to step 9).

7) Measure resistance between switch side of A/C compressor clutch relay terminals. If resistance is infinite, go to next step. If resistance is not infinite, go to step 10).

8) Check A/C compressor clutch relay control circuit (Dark Green/White wire) for short to ground. If problem was found, repair as necessary. After repairs, go to step 17). If problem was not found, go to step 12).

9) Check A/C compressor clutch supply voltage circuit (Dark Green wire) for short to voltage. If problem was found, repair as necessary. After repairs, go to step 17). If problem was not found, go to step 14).

10) Check A/C compressor clutch relay connector for poor connections. If problem was found, repair as necessary. After repairs, go to step 17). If problem was not found, go to step 13).

11) Check HVAC control module connector for poor connections. If problem was found, repair as necessary. After repairs, go to step 17). If problem was not found, go to step 15).

12) Check PCM connectors for poor connections. If problem was found, repair as necessary. After repairs, go to step 17). If problem was not found, go to step 16).

13) Replace A/C compressor clutch relay. After repairs, go to step 17).

14) Replace A/C compressor. See REMOVAL & INSTALLATION in appropriate MANUAL A/C-HEATER SYSTEMS article. After repairs, go to step 17).

15) Replace HVAC control module. See REMOVAL & INSTALLATION in appropriate MANUAL A/C-HEATER SYSTEMS article. After repairs, go to step 17).

16) Replace PCM. See appropriate REMOVAL, OVERHAUL & INSTALLATION article in ENGINE PERFORMANCE. After repairs, go to next step.

17) Operate system to verify repair.

4.3L: "M" & "L" SERIES

NOTE: For circuit, wire color and terminal identification, see WIRING DIAGRAMS. Also see WIRING DIAGRAMS in appropriate MANUAL or AUTOMATIC A/C HEATER SYSTEMS article.

NOTE: HVAC control assembly may be referred to as HVAC control module. 2000 vehicles use a Vehicle Control Module (VCM) and 2001 vehicles use a Powertrain Control Module (PCM).

Description

Regardless of selected A/C mode setting, a request is made to Powertrain Control Module (PCM)/Vehicle Control Module (VCM) to turn on A/C compressor clutch. Request is sent to PCM/VCM through A/C request signal circuit from HVAC control assembly. Power and ground is provided to HVAC control assembly by ignition voltage and ground circuits.

PCM/VCM turns on A/C compressor by providing a path to ground through A/C clutch relay control circuit for A/C compressor clutch relay. Ignition voltage circuit provides power to A/C compressor clutch relay control. Once relay contact closes its internal switch, power from battery voltage circuit is provided to A/C compressor clutch through A/C compressor clutch supply voltage circuit. Whenever compressor is turned off, A/C compressor clutch diode prevents a voltage spike from entering vehicles electrical system. Ground circuit provides a pathway to ground for compressor. Both A/C request signal and A/C clutch relay control circuits are grounded internally within PCM/VCM.

A/C system is protected by 2 pressure switches. A/C high pressure switch interrupts A/C request signal when A/C line pressure exceeds a predetermined value. A/C low pressure switch interrupts A/C low pressure switch signal when A/C line pressure drops below a predetermined value. When PCM/VCM stops receiving required signals, A/C compressor clutch relay control circuit is no longer grounded, thus shutting off compressor.

Compressor Clutch Does Not Engage

1) Ensure outside air temperature is greater than 38°F (3°C). Start engine. Turn blower motor switch to maximum speed position. Place mode switch in bi-level position. Place air temperature control switch in coldest position. If A/C compressor operates, problem is intermittent. If A/C compressor does not operate, go to next step.

2) Park vehicle inside or in shade. Open windows in order to ventilate interior of vehicle. If A/C system was operating, then allow A/C system to equalize for about 2 minutes. Turn ignition switch to OFF position. Install Refrigerant Station (J 43600 ACR 2000). Record outside air temperature at vehicle. Record readings of low and high side static pressures. Compare pressure values with specifications for ambient air temperature. See PRESSURE-TEMPERATURE RELATIONSHIP article in GENERAL SERVICING. If pressure values are within specification for ambient air temperature and within 15 psi (1.1 kg/cm²) of each other, go to next step. If pressure values are not within specification for ambient air temperature or within 15 psi (1.1 kg/cm²) of each other, see LEAK TESTING article in GENERAL SERVICING.

3) If HVAC control assembly is inoperative, go to step 17). If HVAC control assembly is not inoperative, go to next step.

4) Start engine. Using scan tool, observe A/C REQUEST parameter. Place air temperature switch in coldest position. Place mode switch in bi-level position. If scan tool indicates A/C REQUEST parameter is ON, go to step 6). If scan tool does not indicate A/C REQUEST parameter is ON, go to next step.

5) Turn ignition switch to OFF position. Disconnect A/C high pressure switch. Connect fused jumper (3 amp) between A/C request circuits (Light Orange wire and Dark Green/White wire) at A/C high pressure switch connector. Start engine. Using scan tool, observe A/C REQUEST parameter. Place air temperature switch in coldest position. Place mode switch in bi-level position. If scan tool indicated A/C request parameter is ON, go to step 29). If scan tool does not indicate A/C REQUEST parameter is ON, go to step 23).

6) If scan tool indicates A/C LOW PRESSURE SWITCH parameter is CLOSED, go to step 8). If scan tool does not indicate A/C LOW

PRESSURE SWITCH parameter is CLOSED, go to next step.

7) Turn ignition switch to OFF position. Disconnect A/C low pressure switch. Connect fused jumper (3 amp) between A/C low pressure switch signal circuit (Dark Green wire) and ground circuit (Black wire) at A/C low pressure switch connector. Start engine. Using scan tool, observe A/C LOW PRESSURE SWITCH parameter. If scan tool indicates A/C LOW PRESSURE SWITCH parameter is CLOSED, go to step 26). If scan tool does not indicate A/C LOW PRESSURE SWITCH is CLOSED, go to step 19).

8) Using scan tool, command A/C compressor clutch relay on and off. If A/C compressor clutch relay turn on and off with each command, go to step 14). If A/C compressor clutch relay does not turn on and off with each command, go to next step.

9) Turn ignition switch to OFF position. Disconnect A/C compressor clutch relay. Turn ignition switch to ON position, with engine off. Using test light connected to ground, probe coil side voltage supply circuit (Pink wire) of A/C compressor clutch relay. If test light is on, go to next step. If test light is off, go to step 24).

10) Connect test light between control circuit (Dark Green/White wire) of A/C compressor clutch relay and coil side voltage supply circuit (Pink wire) of A/C compressor clutch relay. Using scan tool, command A/C compressor clutch relay on and off. If test light turns on and off with each command, go to step 25). If test light does not turn on and off with each command, go to next step.

11) If test light remains on with each command, go to step 13). If test light does not remain on with each command, go to next step.

12) Check control circuit (Dark Green/White wire) of A/C compressor clutch relay for open. If problem was found, repair as necessary. After repairs, go to step 37). If problem was not found, go to step 30).

13) Check control circuit (Dark Green/White wire) of A/C compressor clutch relay for short to ground. If problem was found, repair as necessary. After repairs, go to step 37). If problem was not found, go to step 30).

14) Turn ignition switch to OFF position. Disconnect A/C compressor clutch relay. Using test light connected to ground, probe switch side voltage supply circuit (Orange wire) of A/C compressor clutch relay. If test light is on, go to next step. If test light is off, go to step 16).

15) Connect fused jumper (10 amp) between switch side voltage circuit (Orange wire) of A/C compressor clutch relay and A/C compressor clutch supply voltage circuit (Dark Green wire) of A/C compressor clutch. Turn ignition switch to ON position, with engine off. If A/C compressor clutch engages, go to step 25). If A/C compressor clutch does not engage, go to step 21).

16) Repair switch side voltage supply circuit of A/C compressor clutch relay. After repairs, go to step 37).

17) Check ignition voltage circuit (Brown wire) of HVAC control assembly for short to ground, high resistance, or open. If problem was found, repair as necessary. After repairs, go to step 37). If problem was not found, go to next step.

18) Check ground circuit (Black wire) of HVAC control assembly for open. If problem was found, repair as necessary. After repairs, go to step 37). If problem was not found, go to step 28).

19) Check A/C low pressure switch signal circuit (Dark Green wire) for high resistance or open. If problem was found, repair as necessary. After repairs, go to step 37). If problem was not found, go to step 20).

20) Check ground circuit (Black wire) of A/C low pressure switch for high resistance or open. If problem was found, repair as necessary. After repairs, go to step 37). If problem was not found, go

to step 30).

21) Check A/C compressor clutch supply voltage circuit (Dark Green wire) at A/C compressor clutch for short to ground, high resistance, or open. If problem was found, repair as necessary. After repairs, go to step 37). If problem was not found, go to next step.

22) Check ground circuit (Black wire) of A/C compressor clutch for high resistance or open. If problem was found, repair as necessary. After repairs, go to step 37). If problem was not found, go to step 27).

23) Turn ignition switch to OFF position. Reconnect A/C high pressure switch. Check A/C request signal circuit (Light Green wire and Dark Green/White wire) for short to ground, high resistance, or open. If problem was found, repair as necessary. After repairs, go to step 37). If problem was not found, go to step 30).

24) Repair coil side voltage supply circuit (Pink wire) of A/C compressor clutch relay. After repairs, go to step 37).

25) Check A/C compressor clutch relay connector for poor connections. If problem was found, repair as necessary. After repairs, go to step 37). If problem was not found, go to step 31).

26) Check A/C low pressure switch connector for poor connections. If problem was found, repair as necessary. After repairs, go to step 37). If problem was not found, go to step 32).

27) Check A/C compressor clutch connector for poor connections. If problem was found, repair as necessary. After repairs, go to step 37). If problem was not found, go to step 34). at the harness connector of the A/C compressor clutch.

28) Check HVAC control assembly connector for poor connections. If problem was found, repair as necessary. After repairs, go to step 37). If problem was not found, go to step 35).

29) Check A/C high pressure switch connector for poor connections. If problem was found, repair as necessary. After repairs, go to step 37). If problem was not found, go to step 33).

30) Check PCM/VCM connectors for poor connections. If problem was found, repair as necessary. After repairs, go to step 37). If problem was not found, go to step 36).

31) Replace A/C compressor clutch relay. After repairs, go to step 37).

32) Replace A/C low pressure switch. After repairs, go to step 37).

33) Replace A/C high pressure switch. After repairs, go to step 37).

34) Replace A/C compressor clutch coil. See appropriate COMPRESSOR SERVICING article in GENERAL SERVICING. After repairs, go to step 37).

35) Replace HVAC control assembly. See REMOVAL & INSTALLATION in appropriate MANUAL A/C-HEATER SYSTEMS article. After repairs, go to step 37).

36) Replace PCM/VCM. See appropriate REMOVAL, OVERHAUL & INSTALLATION article in ENGINE PERFORMANCE. After repairs, go to next step.

37) Operate system to verify repair.

Compressor Clutch Does Not Disengage

1) Start engine. Place blower motor switch in OFF position. Place mode switch in OFF position. If A/C compressor operates, go to next step. If A/C compressor does not operate, problem is intermittent.

2) Using scan tool, observe A/C REQUEST parameter in POWERTRAIN data list. If scan tool indicates A/C REQUEST parameter is ON, go to next step. If scan tool does not indicate A/C REQUEST parameter in ON, go to step 5).

3) Check A/C request signal circuit (Light Green wire and Dark Green/White wire) for short to ground. If problem was found,

repair as necessary. After repairs, go to step 16). If problem was not found, go to next step.

4) Turn ignition switch to OFF position. Disconnect A/C high pressure switch. Start engine. Using scan tool, observe A/C REQUEST parameter. If scan tool indicates A/C REQUEST parameter is ON, go to step 11). If scan tool does not indicate A/C REQUEST parameter is ON, go to step 10).

5) Remove A/C compressor clutch relay. If A/C compressor clutch turns off, go to next step. If A/C compressor clutch does not turn off, go to step 8).

6) Measure resistance between switch side A/C compressor clutch relay terminals. If resistance is infinite, go to next step. If resistance is not infinite, go to step 9).

7) Check A/C clutch relay control circuit (Dark Green/White wire) for short to ground. If problem was found, repair as necessary. After repairs, go to step 16). If problem was not found, go to step 11).

8) Check A/C compressor clutch supply voltage circuit (Dark Green wire) for short to voltage. If problem was found, repair as necessary. After repairs, go to step 16). If problem was not found, go to step 13).

9) Check A/C compressor clutch relay connector for poor connections. If problem was found, repair as necessary. After repairs, go to step 16). If problem was not found, go to step 12).

10) Check HVAC control assembly connector for poor connections. If problem was found, repair as necessary. After repairs, go to step 16). If problem was not found, go to step 14).

11) Check PCM/VCM connectors for poor connections. If problem was found, repair as necessary. After repairs, go to step 16). If problem was not found, go to step 15).

12) Replace A/C compressor clutch relay. After repairs, go to step 16).

13) Replace A/C compressor clutch. See appropriate COMPRESSOR SERVICING article in GENERAL SERVICING. After repairs, go to step 16).

14) Replace HVAC control assembly. See REMOVAL & INSTALLATION in appropriate MANUAL A/C-HEATER SYSTEMS article. After repairs, go to step 16).

15) Replace PCM/VCM. See appropriate REMOVAL, OVERHAUL & INSTALLATION article in ENGINE PERFORMANCE. After repairs, go to next step.

16) Operate system to verify repair.

4.3L: "S" & "T" SERIES (AUTOMATIC A/C)

NOTE: For circuit, wire color and terminal identification, see WIRING DIAGRAMS. Also see WIRING DIAGRAMS in appropriate MANUAL or AUTOMATIC A/C HEATER SYSTEMS article.

Description

A/C system is engaged when HVAC switch is pressed. A/C system can operate regardless of temperature setting, as long as outside ambient temperature is greater than 40°F (4°C). If A/C is selected and A/C is not available, A/C LED will flash, indicating that A/C is not allowed. A/C compressor is activated when FROST DEFROST is selected. A/C will not be allowed if engine exceeds 5985 RPM.

HVAC control module receives power from instrument panel fuse block on ignition voltage circuit along with battery voltage circuit. HVAC control module communicates directly to Powertrain Control Module (PCM)/Vehicle Control Module (VCM) on class 2 serial data and PCM/VCM class 2 serial data circuits through splice pack.

Regardless of selected A/C mode setting, a request is made to

PCM to turn on A/C compressor. Request is made through A/C request signal circuit, through A/C high pressure switch, from HVAC control module.

PCM/VCM turns on A/C compressor by providing a path to ground through A/C clutch relay control circuit for A/C compressor clutch relay. Power is provided to A/C compressor clutch relay internally of underhood fuse block. Once A/C compressor clutch relay closes its internal switch, power from battery is provided to A/C compressor clutch through A/C compressor clutch supply voltage circuit. Whenever compressor is turned off, A/C compressor clutch diode prevents a voltage spike. Ground circuit and underhood fuse block provides a path to ground for compressor. A/C clutch relay control circuit is grounded internally within PCM/VCM.

A/C system is protected by 2 pressure switches. A/C high pressure switch interrupts A/C request signal circuit when A/C line pressures climb greater than 410 psi (28.8 kg/cm²). A/C low pressure switch interrupts A/C low pressure switch signal circuit when A/C line pressures fall below 30 psi (2.1 kg/cm²). When PCM/VCM sees an open in either signal, A/C clutch relay control circuit is no longer grounded, thus shutting off compressor. When high side pressures drop back down to 150-250 psi (10.5-17.6 kg/cm²), PCM/VCM will allow A/C compressor to operate.

Diagnostic System Check

1) Install scan tool. If scan tool powers up, go to next step. If scan tool does not power up, see SCAN TOOL DOES NOT POWER UP in appropriate BODY CONTROL MODULES article.

2) Turn ignition on, engine off. Try to establish scan tool communication with HVAC control module, Body Control Module (BCM) and Powertrain Control Module (PCM)/Vehicle Control Module (VCM). If communication with all modules is established, go to next step. If communication with all modules is not established, see SCAN TOOL DOES NOT COMMUNICATE WITH CLASS 2 DEVICE in appropriate BODY CONTROL MODULES article.

3) Select display DTC function for each module. Record all displayed DTCs, status of displayed DTCs and which module set DTCs. If DTCs are displayed, go to next step. If no DTCs are displayed, see COMPRESSOR CLUTCH DOES NOT ENGAGE or COMPRESSOR CLUTCH DOES NOT DISENGAGE.

4) If scan tool displays DTCs beginning with "B", see appropriate SELF-DIAGNOSTICS article in BODY CONTROL MODULES. If scan tool displays DTCs beginning with "P", see appropriate SELF-DIAGNOSTICS article in ENGINE PERFORMANCE. If scan tool displays DTCs beginning with "U", see SCAN TOOL DOES NOT COMMUNICATE WITH CLASS 2 DEVICE in appropriate BODY CONTROL MODULES article.

Compressor Clutch Does Not Engage

1) If diagnostic system check has not been performed, see DIAGNOSTIC SYSTEM CHECK. If diagnostic system check has been performed, go to next step.

2) Ensure outside air temperature is greater than 38°F (3°C). Start engine. Turn blower motor switch to maximum speed position. Place mode switch in bi-level position. Place air temperature control switch in coldest position. If A/C compressor operates, problem is intermittent. If A/C compressor does not operate, go to next step.

3) Park vehicle inside or in shade. Open windows in order to ventilate interior of vehicle. If A/C system was operating, then allow A/C system to equalize for about 2 minutes. Turn ignition switch to OFF position. Install Refrigerant Station (J 43600 ACR 2000). Record outside air temperature at vehicle. Record readings of low and high side static pressures. Compare pressure values with specifications for

ambient air temperature. See PRESSURE-TEMPERATURE RELATIONSHIP article in GENERAL SERVICING. If pressure values are within specification for ambient air temperature and within 15 psi (1.1 kg/cm²) of each other, go to next step. If pressure values are not within specification for ambient air temperature or within 15 psi (1.1 kg/cm²) of each other, see LEAK TESTING article in GENERAL SERVICING.

4) If HVAC control module is inoperative, go to step 17). If HVAC control module is not inoperative, go to next step.

5) Start engine. Using scan tool, observe A/C REQUEST SIGNAL parameter in POWERTRAIN ENGINE 2 data list. Place air temperature switch in coldest position. Place mode switch in bi-level position. If scan tool indicates A/C REQUEST SIGNAL parameter is YES, go to step 7). If scan tool does not indicate A/C REQUEST SIGNAL parameter is YES, go to next step.

6) Turn ignition switch to OFF position. Disconnect A/C high pressure switch. Connect fused jumper (3 amp) between A/C Request Signal circuits (Light Blue wire and Dark Green/White wire) at A/C high pressure switch connector. Start engine. Using scan tool, observe A/C REQUEST SIGNAL parameter. Place air temperature switch in coldest position. Place mode switch in bi-level position. If scan tool indicates A/C REQUEST SIGNAL parameter is YES, go to step 31). If scan tool does not indicate A/C REQUEST SIGNAL parameter is YES, go to step 23).

7) Turn engine off. Ensure ignition is in ON position. If scan tool indicates A/C COMPRESSOR CYCLING SWITCH parameter reads LOW PRESSURE, go to step 9). If scan tool does not indicate A/C COMPRESSOR CYCLING SWITCH parameter reads LOW PRESSURE, go to next step.

8) Turn ignition switch to OFF position. Disconnect A/C low pressure switch. Connect fused jumper (3 amp) between A/C low pressure switch signal circuit (Dark Green wire) and ground circuit (Black/White wire) at A/C low pressure switch connector. Start engine. Using scan tool, observe A/C COMPRESSOR CYCLING SWITCH parameter. If scan tool indicates A/C COMPRESSOR CYCLING SWITCH parameter reads LOW PRESSURE, go to step 28). If scan tool does not indicate A/C COMPRESSOR CYCLING SWITCH parameter reads LOW PRESSURE, go to step 19).

9) Using scan tool, command A/C relay on and off. If A/C compressor clutch relay turns on and off with each command, go to step 13). If A/C compressor clutch relay does not turn on and off with each command, go to next step.

10) Turn ignition switch to OFF position. Disconnect A/C compressor clutch relay. Turn ignition switch to ON position, with engine off. Using test light connected to ground, probe coil side voltage supply circuit of A/C compressor clutch relay. If test light is on, go to next step. If test light is off, go to step 26).

11) Connect test light between control circuit (Dark Green/White wire) of A/C compressor clutch relay and coil side voltage supply circuit of A/C Relay. Using scan tool, command A/C compressor clutch relay on and off. If test light turns on and off with each command, go to step 27). If test light does not turn on and off with each command, go to next step.

12) If test light remains on with each command, go to step 16). If test light does not remain on with each command, go to step 15).

13) Turn ignition switch to OFF position. Disconnect A/C compressor clutch relay. Using test light connected to ground, probe switch side voltage supply circuit of A/C compressor clutch relay. If test light is on, go to next step. If test light is off, go to step 25).

14) Connect fused jumper (10 amp) between switch side voltage circuit of A/C compressor clutch relay and A/C compressor clutch supply voltage circuit (Dark Green wire) of A/C compressor clutch. If A/C compressor clutch engages, go to step 27). If A/C compressor

clutch does not engage, go to step 21).

15) Check control circuit (Dark Green/White wire) of A/C compressor clutch relay for open or short to voltage. If problem was found, repair as necessary. After repairs, go to step 39). If problem was not found, go to step 32).

16) Check control circuit (Dark Green/White wire) of A/C compressor clutch relay for short to ground. If problem was found, repair as necessary. After repairs, go to step 39). If problem was not found, go to step 32).

17) Check ignition voltage circuit (Brown wire) of HVAC control assembly for short to ground, high resistance, or open. If problem was found, repair as necessary. After repairs, go to step 39). If problem was not found, go to next step.

18) Check ground circuit (Black wire) of HVAC control assembly for open. If problem was found, repair as necessary. After repairs, go to step 39). If problem was not found, go to step 30).

19) Check A/C low pressure switch signal circuit (Dark Green wire) for high resistance or open. If problem was found, repair as necessary. After repairs, go to step 39). If problem was not found, go to next step.

20) Check ground circuit (Black/White wire) of A/C low pressure switch for high resistance or open. If problem was found, repair as necessary. After repairs, go to step 39). If problem was not found, go to step 32).

21) Check A/C compressor clutch supply voltage circuit (Dark Green wire) at A/C compressor clutch for short to ground, high resistance, or open. If problem was found, repair as necessary. After repairs, go to step 39). If problem was not found, go to next step.

22) Check ground circuit (Black wire) of A/C compressor clutch for high resistance or open. If problem was found, repair as necessary. After repairs, go to step 39). If problem was not found, go to step 29).

23) Turn ignition switch to OFF position. Reconnect A/C high pressure switch. Check A/C request signal circuit (Light Green wire and Dark Green/White wire) for short to ground, high resistance, or open. If problem was found, repair as necessary. After repairs, go to step 39). If problem was not found, go to next step.

24) Turn ignition switch to OFF position. Disconnect A/C high pressure switch. Turn ignition switch to ON position. Place mode switch in bi-level position. Using test light connected to ground, probe A/C request signal circuit (Light Blue wire) of A/C high pressure switch. If test light is on, go to step 32). If test light is off, go to step 30).

25) Repair switch side voltage supply circuit of A/C compressor clutch relay. After repairs, go to step 39).

26) Repair coil side voltage supply circuit of A/C compressor clutch relay. After repairs, go to step 39).

27) Check A/C compressor clutch relay connector for poor connections. If problem was found, repair as necessary. After repairs, go to step 39). If problem was not found, go to step 33).

28) Check A/C low pressure switch connector for poor connections. If problem was found, repair as necessary. After repairs, go to step 39). If problem was not found, go to step 34).

29) Check A/C compressor clutch connector for poor connections. If problem was found, repair as necessary. After repairs, go to step 39). If problem was not found, go to step 36).

30) Check HVAC control module connector for poor connections. If problem was found, repair as necessary. After repairs, go to step 39). If problem was not found, go to step 37).

31) Check A/C high pressure switch connector for poor connections. If problem was found, repair as necessary. After repairs, go to step 39). If problem was not found, go to step 35).

32) Check PCM/VCM connectors for poor connections. If problem

was found, repair as necessary. After repairs, go to step 39). If problem was not found, go to step 38).

33) Replace A/C compressor clutch relay. After repairs, go to step 39).

34) Replace A/C low pressure switch. After repairs, go to step 39).

35) Replace A/C high pressure switch. After repairs, go to step 39).

36) Replace A/C compressor clutch coil. See appropriate COMPRESSOR SERVICING article in GENERAL SERVICING. After repairs, go to step 39).

37) Replace HVAC control assembly. See REMOVAL & INSTALLATION in appropriate AUTOMATIC A/C-HEATER SYSTEMS article. After repairs, go to step 39).

38) Replace PCM/VCM. See appropriate REMOVAL, OVERHAUL & INSTALLATION article in ENGINE PERFORMANCE. After repairs, go to next step.

39) Operate system to verify repair.

Compressor Clutch Does Not Disengage

1) If diagnostic system check has not been performed, see DIAGNOSTIC SYSTEM CHECK. If diagnostic system check has been performed, go to next step.

2) Start engine. Place blower motor switch in OFF position. Place A/C request switch in OFF position. If A/C compressor clutch engages, go to next step. If A/C compressor clutch does not engage, problem is intermittent.

3) Using scan tool, observe A/C REQUEST parameter in POWERTRAIN data list. If scan tool indicates A/C REQUEST parameter is ON, go to next step. If scan tool does not indicate A/C REQUEST parameter is ON, go to step 6).

4) Check A/C request signal circuit (Light Blue wire and Dark Green/White wire) for short to ground. If problem was found, repair as necessary. After repairs, go to step 17). If problem was not found, go to next step.

5) Turn ignition switch to OFF position. Disconnect A/C high pressure switch. Start engine. Using scan tool, observe A/C REQUEST parameter. If scan tool indicates A/C REQUEST parameter is ON, go to step 12). If scan tool does not indicate A/C REQUEST parameter is ON, go to step 11).

6) Remove A/C compressor clutch relay. If A/C compressor clutch turns off, go to next step. If A/C compressor clutch does not turn off, go to step 9).

7) Measure resistance between switch side A/C compressor clutch relay terminals. If resistance is infinite, go to next step. If resistance is not infinite, go to step 10).

8) Check A/C clutch relay control circuit (Dark Green/White wire) for short to ground. If problem was found, repair as necessary. After repairs, go to step 17). If problem was not found, go to step 12).

9) Check A/C compressor clutch supply voltage circuit (Dark Green wire) for short to voltage. If problem was found, repair as necessary. After repairs, go to step 17). If problem was not found, go to step 14).

10) Check A/C compressor clutch relay connector for poor connections. If problem was found, repair as necessary. After repairs, go to step 17). If problem was not found, go to step 13).

11) Check HVAC control module connector for poor connections. If problem was found, repair as necessary. After repairs, go to step 17). If problem was not found, go to step 15).

12) Check PCM/VCM connectors for poor connections. If problem was found, repair as necessary. After repairs, go to step 17). If problem was not found, go to step 16).

13) Replace A/C compressor clutch relay. After repairs, go to step 17).

14) Replace A/C compressor clutch. See appropriate COMPRESSOR SERVICING article in GENERAL SERVICING. After repairs, go to step 17).

15) Replace HVAC control module. See REMOVAL & INSTALLATION in appropriate AUTOMATIC A/C-HEATER SYSTEMS article. After repairs, go to step 17).

16) Replace PCM/VCM. See appropriate REMOVAL, OVERHAUL & INSTALLATION article in ENGINE PERFORMANCE. After repairs, go to next step.

17) Operate system to verify repair.

4.3L: "S" & "T" SERIES (MANUAL A/C)

NOTE: For circuit, wire color and terminal identification, see WIRING DIAGRAMS. Also see WIRING DIAGRAMS in appropriate MANUAL or AUTOMATIC A/C HEATER SYSTEMS article.

Description

Vehicle operator can activate A/C system by activating the following modes: MAX A/C, A/C BI-LEVEL, MIX-BLEND or FRONT DEFROST. A/C system can operate regardless of temperature setting, as long as ambient air temperature is greater than 38°F (3°C) degrees. If A/C compressor clutch is turned off due to cold ambient air temperatures, compressor will not come back on until ambient air temperatures reach 41°F (5°C).

Regardless of selected A/C mode setting, a request is made to Powertrain Control Module (PCM)/Vehicle Control Module (VCM) to turn on A/C compressor. Request is made through A/C request signal circuit from HVAC control assembly. Power is provided to HVAC control assembly by ignition voltage.

In order for PCM/VCM to internally ground A/C clutch relay control circuit, 2 separate request signals need to be grounded. A 12-volt request signal is sent out over A/C request signal circuit, through A/C high pressure switch, and grounded through PCM/VCM when vehicle operator makes an A/C request. A separate 12-volt request signal is sent out over A/C low pressure switch signal circuit, through A/C low pressure switch and ground circuit. When both these request signals are grounded, PCM/VCM can activate A/C compressor clutch.

PCM/VCM turns on A/C compressor by providing a path to ground through A/C clutch relay control circuit for A/C compressor clutch relay. Power is provided to A/C compressor clutch relay internally of underhood fuse block. Once relay closes its internal switch, power from battery is provided to A/C compressor clutch through A/C compressor clutch supply voltage circuit. Whenever compressor is turned off, A/C compressor clutch diode prevents a voltage spike from burning up compressor clutch coil. Ground circuit and underhood fuse block provides a path to ground for compressor. A/C clutch relay control circuit is grounded internally within PCM/VCM.

A/C system is protected by 2 pressure switches. A/C high pressure switch interrupts A/C request signal when A/C line pressures climb greater than 410 psi (28.8 kg/cm²). A/C low pressure switch interrupts A/C low pressure switch signal when A/C line pressure fall below 30 psi (2.1 kg/cm²). When the PCM/VCM sees an open in either signal, A/C clutch relay control circuit is no longer grounded, thus shutting off compressor. When high side pressures drop back down between 150-250 psi (10.5-17.6 kg/cm²), PCM/VCM will allow the A/C compressor to operate.

Diagnostic System Check

1) Install scan tool. If scan tool powers up, go to next step. If scan tool does not power up, see SCAN TOOL DOES NOT POWER UP in appropriate BODY CONTROL MODULES article.

2) Turn ignition on, engine off. Try to establish scan tool communication with Powertrain Control Module (PCM)/Vehicle Control Module (VCM). If communication with PCM is established, go to next step. If communication with PCM is not established, see SCAN TOOL DOES NOT COMMUNICATE WITH CLASS 2 DEVICE in appropriate BODY CONTROL MODULES article.

3) Select display DTC function for PCM. Record all displayed DTCs and status of displayed DTCs. If DTCs are displayed, go to next step. If no DTCs are displayed, see COMPRESSOR CLUTCH DOES NOT ENGAGE or COMPRESSOR CLUTCH DOES NOT DISENGAGE.

4) If scan tool does not display DTCs beginning with "U", see appropriate SELF-DIAGNOSTICS article in ENGINE PERFORMANCE. If scan tool displays DTCs beginning with "U", see SCAN TOOL DOES NOT COMMUNICATE WITH CLASS 2 DEVICE in appropriate BODY CONTROL MODULES article.

Compressor Clutch Does Not Engage

1) If diagnostic system check has not been performed, see DIAGNOSTIC SYSTEM CHECK. If diagnostic system check has been performed, go to next step.

2) Ensure outside air temperature is greater than 38°F (3°C). Start engine. Turn blower motor switch to maximum speed position. Place mode switch in bi-level position. Place air temperature control switch in coldest position. If A/C compressor operates, problem is intermittent. If A/C compressor does not operate, go to next step.

3) Park vehicle inside or in shade. Open windows in order to ventilate interior of vehicle. If A/C system was operating, then allow A/C system to equalize for about 2 minutes. Turn ignition switch to OFF position. Install Refrigerant Station (J 43600 ACR 2000). Record outside air temperature at vehicle. Record readings of low and high side static pressures. Compare pressure values with specifications for ambient air temperature. See PRESSURE-TEMPERATURE RELATIONSHIP article in GENERAL SERVICING. If pressure values are within specification for ambient air temperature and within 15 psi (1.1 kg/cm²) of each other, go to next step. If pressure values are not within specification for ambient air temperature or within 15 psi (1.1 kg/cm²) of each other, see LEAK TESTING article in GENERAL SERVICING.

4) If HVAC control module is inoperative, go to step 17). If HVAC control module is not inoperative, go to next step.

5) Start engine. Using scan tool, observe A/C REQUEST SIGNAL parameter in POWERTRAIN ENGINE 2 data list. Place air temperature switch in coldest position. Place mode switch in bi-level position. If scan tool indicates A/C REQUEST SIGNAL parameter is YES, go to step 7). If scan tool does not indicate A/C REQUEST SIGNAL parameter is YES, go to next step.

6) Turn ignition switch to OFF position. Disconnect A/C high pressure switch. Connect fused jumper (3 amp) between A/C Request Signal circuits (Light Blue wire and Dark Green/White wire) at A/C high pressure switch connector. Start engine. Using scan tool, observe A/C REQUEST SIGNAL parameter. Place air temperature switch in coldest position. Place mode switch in bi-level position. If scan tool indicates A/C REQUEST SIGNAL parameter is YES, go to step 31). If scan tool does not indicate A/C REQUEST SIGNAL parameter is YES, go to step 23).

7) Turn engine off. Ensure ignition is in ON position. If scan tool indicates A/C COMPRESSOR CYCLING SWITCH parameter reads LOW PRESSURE, go to step 9). If scan tool does not indicate A/C COMPRESSOR CYCLING SWITCH parameter reads LOW PRESSURE, go to next step.

8) Turn ignition switch to OFF position. Disconnect A/C low pressure switch. Connect fused jumper (3 amp) between A/C low pressure switch signal circuit (Dark Green wire) and ground circuit (Black/White wire) at A/C low pressure switch connector. Start engine. Using scan tool, observe A/C COMPRESSOR CYCLING SWITCH parameter. If scan tool indicates A/C COMPRESSOR CYCLING SWITCH parameter reads LOW PRESSURE, go to step 28). If scan tool does not indicate A/C COMPRESSOR CYCLING SWITCH parameter reads LOW PRESSURE, go to step 19).

9) Using scan tool, command A/C relay on and off. If A/C compressor clutch relay turns on and off with each command, go to step 13). If A/C compressor clutch relay does not turn on and off with each command, go to next step.

10) Turn ignition switch to OFF position. Disconnect A/C compressor clutch relay. Turn ignition switch to ON position, with engine off. Using test light connected to ground, probe coil side voltage supply circuit of A/C compressor clutch relay. If test light is on, go to next step. If test light is off, go to step 26).

11) Connect test light between control circuit (Dark Green/White wire) of A/C compressor clutch relay and coil side voltage supply circuit of A/C Relay. Using scan tool, command A/C compressor clutch relay on and off. If test light turns on and off with each command, go to step 27). If test light does not turn on and off with each command, go to next step.

12) If test light remains on with each command, go to step 16). If test light does not remain on with each command, go to step 15).

13) Turn ignition switch to OFF position. Disconnect A/C compressor clutch relay. Using test light connected to ground, probe switch side voltage supply circuit of A/C compressor clutch relay. If test light is on, go to next step. If test light is off, go to step 25).

14) Connect fused jumper (10 amp) between switch side voltage circuit of A/C compressor clutch relay and A/C compressor clutch supply voltage circuit (Dark Green wire) of A/C compressor clutch. If A/C compressor clutch engages, go to step 27). If A/C compressor clutch does not engage, go to step 21).

15) Check control circuit (Dark Green/White wire) of A/C compressor clutch relay for open or short to voltage. If problem was found, repair as necessary. After repairs, go to step 39). If problem was not found, go to step 32).

16) Check control circuit (Dark Green/White wire) of A/C compressor clutch relay for short to ground. If problem was found, repair as necessary. After repairs, go to step 39). If problem was not found, go to step 32).

17) Check ignition voltage circuit (Brown wire) of HVAC control assembly for short to ground, high resistance, or open. If problem was found, repair as necessary. After repairs, go to step 39). If problem was not found, go to next step.

18) Check ground circuit (Black wire) of HVAC control assembly for open. If problem was found, repair as necessary. After repairs, go to step 39). If problem was not found, go to step 30).

19) Check A/C low pressure switch signal circuit (Dark Green wire) for high resistance or open. If problem was found, repair as necessary. After repairs, go to step 39). If problem was not found, go to next step.

20) Check ground circuit (Black/White wire) of A/C low pressure switch for high resistance or open. If problem was found, repair as necessary. After repairs, go to step 39). If problem was not found, go to step 32).

21) Check A/C compressor clutch supply voltage circuit (Dark Green wire) at A/C compressor clutch for short to ground, high resistance, or open. If problem was found, repair as necessary. After

repairs, go to step 39). If problem was not found, go to next step.

22) Check ground circuit (Black wire) of A/C compressor clutch for high resistance or open. If problem was found, repair as necessary. After repairs, go to step 39). If problem was not found, go to step 29).

23) Turn ignition switch to OFF position. Reconnect A/C high pressure switch. Check A/C request signal circuit (Light Green wire and Dark Green/White wire) for short to ground, high resistance, or open. If problem was found, repair as necessary. After repairs, go to step 39). If problem was not found, go to next step.

24) Turn ignition switch to OFF position. Disconnect A/C high pressure switch. Turn ignition switch to ON position. Place mode switch in bi-level position. Using test light connected to ground, probe A/C request signal circuit (Light Blue wire) of A/C high pressure switch. If test light is on, go to step 32). If test light is off, go to step 30).

25) Repair switch side voltage supply circuit of A/C compressor clutch relay. After repairs, go to step 39).

26) Repair coil side voltage supply circuit of A/C compressor clutch relay. After repairs, go to step 39).

27) Check A/C compressor clutch relay connector for poor connections. If problem was found, repair as necessary. After repairs, go to step 39). If problem was not found, go to step 33).

28) Check A/C low pressure switch connector for poor connections. If problem was found, repair as necessary. After repairs, go to step 39). If problem was not found, go to step 34).

29) Check A/C compressor clutch connector for poor connections. If problem was found, repair as necessary. After repairs, go to step 39). If problem was not found, go to step 36).

30) Check HVAC control module connector for poor connections. If problem was found, repair as necessary. After repairs, go to step 39). If problem was not found, go to step 37).

31) Check A/C high pressure switch connector for poor connections. If problem was found, repair as necessary. After repairs, go to step 39). If problem was not found, go to step 35).

32) Check PCM/VCM connectors for poor connections. If problem was found, repair as necessary. After repairs, go to step 39). If problem was not found, go to step 38).

33) Replace A/C compressor clutch relay. After repairs, go to step 39).

34) Replace A/C low pressure switch. After repairs, go to step 39).

35) Replace A/C high pressure switch. After repairs, go to step 39).

36) Replace A/C compressor clutch coil. See appropriate COMPRESSOR SERVICING article in GENERAL SERVICING. After repairs, go to step 39).

37) Replace HVAC control assembly. See REMOVAL & INSTALLATION in appropriate AUTOMATIC A/C-HEATER SYSTEMS article. After repairs, go to step 39).

38) Replace PCM/VCM. See appropriate REMOVAL, OVERHAUL & INSTALLATION article in ENGINE PERFORMANCE. After repairs, go to next step.

39) Operate system to verify repair.

Compressor Clutch Does Not Disengage

1) If diagnostic system check has not been performed, see DIAGNOSTIC SYSTEM CHECK. If diagnostic system check has been performed, go to next step.

2) Start engine. Place blower motor switch in OFF position. Place mode switch in OFF position. If A/C compressor clutch engages, go to next step. If A/C compressor clutch does not engage, problem is intermittent.

3) Using scan tool, observe A/C REQUEST SIGNAL parameter in POWERTRAIN data list. If scan tool indicates A/C REQUEST SIGNAL parameter is ON, go to next step. If scan tool does not indicate A/C REQUEST SIGNAL parameter is ON, go to step 6).

4) Check A/C request signal circuit (Light Blue wire and Dark Green/White wire) for short to ground. If problem was found, repair as necessary. After repairs, go to step 17). If problem was not found, go to next step.

5) Turn ignition switch to OFF position. Disconnect A/C high pressure switch. Start engine. Using scan tool, observe A/C REQUEST SIGNAL parameter. If scan tool indicates A/C REQUEST SIGNAL parameter is ON, go to step 12). If scan tool does not indicate A/C REQUEST SIGNAL parameter is ON, go to step 11).

6) Remove A/C compressor clutch relay. If A/C compressor clutch turns off, go to next step. If A/C compressor clutch does not turn off, go to step 9).

7) Measure resistance between switch side A/C compressor clutch relay terminals. If resistance is infinite, go to next step. If resistance is not infinite, go to step 10).

8) Check A/C clutch relay control circuit (Dark Green/White wire) for short to ground. If problem was found, repair as necessary. After repairs, go to step 17). If problem was not found, go to step 12).

9) Check A/C compressor clutch supply voltage circuit (Dark Green wire) for short to voltage. If problem was found, repair as necessary. After repairs, go to step 17). If problem was not found, go to step 14).

10) Check A/C compressor clutch relay connector for poor connections. If problem was found, repair as necessary. After repairs, go to step 17). If problem was not found, go to step 13).

11) Check HVAC control module connector for poor connections. If problem was found, repair as necessary. After repairs, go to step 17). If problem was not found, go to step 15).

12) Check PCM/VCM connectors for poor connections. If problem was found, repair as necessary. After repairs, go to step 17). If problem was not found, go to step 16).

13) Replace A/C compressor clutch relay. After repairs, go to step 17).

14) Replace A/C compressor clutch. See appropriate COMPRESSOR SERVICING article in GENERAL SERVICING. After repairs, go to step 17).

15) Replace HVAC control module. See REMOVAL & INSTALLATION in appropriate AUTOMATIC A/C-HEATER SYSTEMS article. After repairs, go to step 17).

16) Replace PCM/VCM. See appropriate REMOVAL, OVERHAUL & INSTALLATION article in ENGINE PERFORMANCE. After repairs, go to next step.

17) Operate system to verify repair.

4.3L & 7.4L: "C" & "K" SERIES (2000) 4.3L, 5.0L & 5.7L: "G" SERIES (2000)

NOTE: For circuit, wire color and terminal identification, see WIRING DIAGRAMS. Also see WIRING DIAGRAMS in appropriate MANUAL or AUTOMATIC A/C HEATER SYSTEMS article.

Description

A/C clutch relay is controlled by Vehicle Control Module (VCM) to delay A/C compressor clutch engagement after A/C is turned on. This allows VCM to adjust engine RPM before A/C compressor clutch engages. VCM will engage A/C compressor clutch any time A/C has been requested unless coolant temperature is high, A/C system pressure is low, A/C system pressure is high, wide open throttle, or engine RPM is high.

When A/C-heater control panel is placed in A/C mode, a 12-volt signal is sent to VCM. When VCM receives this signal, VCM will ground A/C clutch relay control circuit to energize A/C clutch relay. This is shown on scan tool as A/C REQUEST YES.

When an A/C request has been detected by VCM, VCM will ground A/C clutch relay control circuit. As a result, relay contacts close, allowing current to flow through relay to A/C compressor clutch. When A/C REQUEST has been detected by VCM, cooling fans will turn on when A/C pressure is greater than a predetermined value.

Diagnosis

1) If On-Board Diagnostic (OBD) System Check has not been performed, see appropriate SELF-DIAGNOSTICS article in ENGINE PERFORMANCE. If OBD System Check has been performed, go to next step.

2) This diagnostic test assumes the following:

- * A/C system is adequately charged.
- * This table only diagnoses control of A/C compressor clutch.
- * A/C compressor has no mechanical failures.
- * Engine coolant temperature is more than 140°F (60°C), but less than 250°F (121°C).
- * HVAC control module is functioning.

Start and idle engine. Turn off HVAC controls. If A/C compressor clutch engaged, go to step 4). If A/C compressor clutch did not engage, go to next step.

3) Start engine. Idle engine until normal operating temperature is reached. Leave engine at normal idle. Turn A/C on. If A/C clutch engage within 60 seconds, see DIAGNOSTIC AIDS. If A/C clutch does not engage within 60 seconds, go to step 7).

4) Disconnect A/C clutch relay from underhood electrical center. If A/C compressor clutch stays engaged, go to next step. If A/C compressor clutch does not stay engaged, go to step 6).

5) Check for short to voltage in Dark Green wire between A/C clutch relay and A/C compressor clutch. If problem was found, go to step 33). If problem was not found, go to step 17).

6) Using test light connected to battery voltage, probe A/C clutch relay control circuit (Dark Green/White wire) at underhood electrical center. If test light is on, go to step 24). If test light is off, go to step 29).

7) Install scan tool. Start engine. Turn A/C on. Monitor A/C REQUEST in scan tool data list. A/C request should display YES. If scan tool displays YES, go to next step. If scan tool does not display YES, go to step 18).

8) Monitor A/C EVAPORATOR SWITCH with scan tool. Turn A/C on. If scan tool indicates switch is CLOSED, go to step 12). If scan tool does not indicate switch is CLOSED, go to next step.

9) Disconnect A/C evaporator cycling cutoff switch connector. Turn ignition switch to ON position, with engine off. Using fused jumper, connect Dark Green wire at A/C evaporator cycling cutoff switch connector to ground. If scan tool indicates switch is CLOSED, go to next step. If scan tool does not indicate switch is CLOSED, go to step 31).

10) Using test light connected to battery voltage, probe ground circuit (Black wire) of A/C evaporator cycling cutoff switch connector. If test light is on, go to next step. If test light is off, go to step 33).

11) Replace A/C high pressure cutoff switch. After repairs, go to step 35).

CAUTION: Avoid contact with moving parts and hot surfaces while working around a running engine in order to prevent physical injury.

12) Turn engine off. Disconnect A/C compressor clutch harness connector. Start engine. Turn A/C on. Using test light connected to ground, probe A/C clutch voltage supply circuit (Dark Green wire) at A/C compressor clutch harness connector. If test light is on, go to next step. If test light is off, go to step 20).

13) Using test light connected to ground, probe A/C clutch ground circuit (Black wire) at A/C clutch connector. If test light is on, go to step 15). If test light is off, go to next step.

14) Repair A/C clutch ground circuit (Black wire). After repairs, go to step 35).

15) Check A/C compressor clutch connector for poor connections. If problem was found, go to next step. If problem was not found, go to step 17).

16) Repair A/C compressor clutch connector. After repairs, go to step 35).

17) Replace A/C compressor clutch. See appropriate COMPRESSOR SERVICING article in GENERAL SERVICING. After repairs, go to step 35).

18) Turn ignition switch to OFF position. Disconnect VCM connector C3. Turn ignition switch to ON position, with engine off. Turn A/C on. Using test light connected to ground, probe the VCM connector C3 terminal No. 25 (Dark Green/White wire). If test light is on, go to step 32). If test light is off, go to next step.

19) Check for open in A/C request signal circuit (Light Blue wire and Dark Green/White wire) between HVAC control module and VCM. If problem was found, go to step 33). If problem was not found, see TESTING in appropriate MANUAL A/C-HEATER SYSTEMS article.

20) Reconnect A/C clutch connector. Install scan tool. Turn ignition switch to ON position, with engine off. Using scan tool, command A/C relay on. If A/C relay clicks, go to step 26). If A/C relay does not click, go to next step.

21) Disconnect A/C relay. Turn ignition switch to ON position, with engine off. Using test light connected to ground, probe ignition voltage circuit (Pink wire on 7.4L) at A/C relay connector. If test light is on, go to step 23). If test light is off, go to next step.

22) Repair open in A/C relay ignition voltage circuit (Pink wire on 7.4L). If fuse is blown, repair short to ground in A/C relay ignition voltage circuit. After repairs, go to step 35).

23) Using test light connected to battery voltage, probe A/C relay control circuit (Dark Green/White wire) at A/C relay connector. Using scan tool, command A/C relay on. If test light is on, go to step 29). If test light is off, go to next step.

24) Check for open, short to voltage or short to ground in A/C relay control circuit (Dark Green/White wire) between the underhood fuse block and VCM connector C3. If problem was found, go to next step. If problem was not found, go to step 32).

25) Repair Dark Green/White wire between underhood fuse block and VCM connector C3. After repairs, go to step 35).

26) Remove A/C compressor clutch relay. Using test light connected to ground, probe battery voltage circuit (Orange wire on 7.4L) at A/C compressor clutch relay connector. If test light is on, go to step 28). If test light is off, go to next step.

27) Repair open in A/C relay battery voltage feed circuit (Pink wire on 7.4L). If fuse is blown, repair short to ground in A/C relay battery voltage circuit. After repairs, go to step 35).

28) Turn ignition switch to ON position, with engine off. Using fused jumper, connect A/C relay battery voltage feed circuit to A/C clutch voltage supply circuit (Dark Green wire) at A/C compressor clutch relay connector. If A/C clutch engages, go to next step. If A/C

clutch does not engage, go to step 30).

29) Replace A/C compressor clutch relay. After repairs, go to step 35).

30) Repair open or short to ground in A/C compressor clutch control circuit (Dark Green/White wire). After repairs, go to step 35).

31) Check for open in A/C cycling signal circuit (Dark Green wire). If problem was found, go to step 33). If problem was not found, go to next step.

32) Check VCM connectors for poor connections. If problem was found, go to next step. If problem was not found, go to step 34).

33) Repair circuit as necessary. After repairs, go to step 35).

34) Replace VCM. See appropriate REMOVAL, OVERHAUL & INSTALLATION article in ENGINE PERFORMANCE. After repairs, go to next step.

35) Start engine. Idle engine until normal operating temperature is reached. Leave engine at normal idle. Turn A/C on. A/C clutch should engage within 60 seconds. Using scan tool, check for DTCs. If DTCs are not present, system is okay.

Diagnostic Aids

Intermittent conditions can be caused by poor connections, rubbed wire through insulation or a broken wire within the insulation. Check circuits thoroughly. For additional information, see appropriate MANUAL A/C-HEATER SYSTEMS article.

4.8L, 5.3L & 6.0L: "C" & "K" SERIES (2000)

NOTE: For circuit, wire color and terminal identification, see WIRING DIAGRAMS. Also see WIRING DIAGRAMS in appropriate MANUAL or AUTOMATIC A/C HEATER SYSTEMS article.

Description

PCM controls operation of A/C clutch relay. When any A/C mode is selected on Heating, Ventilation and Air Conditioning (HVAC) control module, a 12-volt signal is sent through A/C high pressure switch and to PCM. If conditions are met, PCM will send another 12-volt signal to A/C compressor cycling switch, which is ground signal. When these 2 signals are received by PCM, PCM supplies a ground for A/C compressor clutch relay.

PCM controlled HVAC system consists of the following components:

- * A/C high pressure switch.
- * A/C compressor cycling switch.
- * A/C compressor relay.
- * PCM

PCM will engage A/C compressor clutch unless one or more of the following conditions occur:

- * Throttle angle at 100 percent.
- * A/C compressor cycling switch pressure is less than 18 psi (1.2 km/cm²) or greater than 49 psi (3.4 km/cm²).
- * A/C high pressure cut-out switch pressure is greater than 420 psi (29.5 km/cm²).
- * Engine speed is greater than 5500 RPM.
- * Engine coolant temperature greater than 250°F (121°C).

Any condition described above will prevent operation of A/C compressor clutch.

Diagnosis

1) If On-Board Diagnostic (OBD) System Check has not been performed, see appropriate SELF-DIAGNOSTICS article in ENGINE PERFORMANCE. If OBD System Check has been performed, go to next step.

2) This diagnostic procedure only diagnoses the A/C compressor clutch circuit. This procedure assumes the following conditions are true:

- * A/C system is fully charged.
- * A/C compressor has no mechanical failures.
- * Engine coolant temperature is greater than 140°F (60°C), but less than 250°F (121°C).
- * HVAC control module is functioning normally.

Start engine and turn HVAC controls to off position. If A/C compressor clutch is engaged, go to step 12). If A/C compressor clutch is not engaged, go to next step.

3) Select any A/C position on HVAC control panel. Set blower switch to high. If A/C compressor clutch engages, system is operating properly at this time. If A/C compressor clutch is not engaged, go to next step.

4) Check condition of both A/C and IGN E fuses (10 amp). If both fuses are okay, go to next step. If one or more fuses are blown, go to step 28).

5) Connect scan tool and monitor A/C request signal. If scan tool displays A/C request as YES, go to next step. If scan tool does not display A/C request as YES, go to step 20).

6) Monitor A/C compressor cycling switch signal with scan tool. If scan tool displays A/C cycling switch as closed, go to next step. If scan tool does not display A/C cycling switch as closed, go to step 24).

7) Turn ignition switch to OFF position. Disconnect A/C clutch relay. Turn ignition switch on, engine off. Using test light connected to battery voltage, probe A/C clutch relay control circuit (Dark Green/White wire). See WIRING DIAGRAMS. Using scan tool, command A/C clutch relay on and off. If test light turns on and off, go to next step. If test light does not turn on and off, go to step 31).

8) Using test light connected to ground, probe both A/C relay battery voltage supply circuits. If test light comes on at both terminals, go to next step. If test light does not come on at both terminals, go to step 32).

9) Connect a fused jumper between battery voltage circuit and A/C compressor clutch circuit (Dark Green wire). If A/C compressor clutch engages, go to step 34). If A/C compressor clutch does not engage, go to next step.

10) Using fused jumper connected, raise and support vehicle. Disconnect A/C compressor clutch connector. Using test light connected to ground, probe A/C compressor clutch connector feed from relay terminal (Dark Green wire). If test light comes on, go to next step. If test light does not come on, go to step 33).

11) Connect a test light between terminals of A/C compressor clutch connector. If test light comes on, go to step 35). If test light does not come on, go to step 36).

12) Monitor A/C request signal on scan tool. If scan tool indicates A/C request as YES, go to next step. If scan tool indicates A/C request as NO, go to step 16).

13) Disconnect A/C high pressure cut-out switch located on rear of compressor. If scan tool indicates A/C request as YES, go to next step. If scan tool indicates A/C request as NO, diagnose A/C-heater system. See appropriate MANUAL or AUTOMATIC A/C-HEATER SYSTEMS article.

14) Turn ignition switch to OFF position. Disconnect PCM

connector C2. Turn ignition switch to ON position. Use a DVOM to measure voltage between PCM connector C2 A/C request terminal (Dark Green/White wire) and ground. If any voltage reading is indicated, go to step 37). If no voltage reading is indicated, go to next step.

15) Turn ignition switch to OFF position. Use a DVOM to measure resistance between A/C request terminal (Dark Green/White wire) and all other terminals at connector C2. If reading is 0-2 ohms at any terminal, go to step 38). If reading is not 0-2 ohms at any terminal, go to step 55).

16) Disconnect A/C clutch relay. If A/C compressor clutch disengages, go to next step. If A/C compressor clutch does not disengage, go to step 39).

17) Using test light connected to battery voltage, probe A/C clutch relay control circuit (Dark Green/White wire) at relay connector. If test light comes on, go to next step. If test light does not come on, go to step 40).

18) Turn ignition switch to OFF position. Disconnect PCM connector C2. Using test light connected to battery voltage, probe A/C clutch relay control circuit terminal (Dark Green/White wire) at PCM connector C2. If test light comes on, go to step 41). If test light does not come on, go to next step.

19) Using DVOM, measure resistance between A/C clutch relay control circuit terminal (Dark Green/White wire) and all other terminals at connector C2. If reading is 0-2 ohms at any terminal, go to step 42). If reading is not 0-2 ohms at any terminal, go to step 55).

20) Turn engine off. Disconnect A/C high pressure cut-out switch located on rear of compressor. Turn ignition switch to ON position. Using DVOM, measure voltage between ground and A/C request circuit (Dark Green/White wire) on HVAC module side. If battery voltage is indicated, go to next step. If battery voltage is not indicated, diagnose A/C-heater system. See appropriate MANUAL or AUTOMATIC A/C-HEATER SYSTEMS article.

21) Connect a fused jumper wire between A/C high pressure cut-out switch connector terminals. Start engine and monitor A/C REQUEST on scan tool. If scan tool indicates A/C REQUEST as YES, go to step 43). If scan tool does not indicate A/C REQUEST as YES, go to next step.

22) Turn ignition switch to OFF position. Disconnect PCM connector C2. Using DVOM, check for continuity of A/C request signal circuit between PCM and A/C high pressure cut-out switch (Dark Green/White wire). If continuity is indicated, go to next step. If continuity is not indicated, go to step 45).

23) Using DVOM, check continuity of A/C request signal circuit to ground. If continuity is indicated, go to step 46). If continuity is not indicated, go to step 54).

24) Turn engine off. Disconnect A/C compressor cycling switch connector to the accumulator. Turn ignition switch to ON position. Using DVOM, measure voltage between battery ground and A/C compressor cycling switch signal circuit (Dark Green wire). If battery voltage is indicated, go to next step. If battery voltage is not indicated, go to step 26).

25) Connect a fused jumper wire between A/C compressor cycling switch connector terminals. If scan tool indicates A/C COMPRESSOR CYCLING SWITCH as CLOSED, go to step 47). If scan tool does not indicate A/C COMPRESSOR CYCLING SWITCH as CLOSED, go to step 49).

26) Turn ignition switch to OFF position. Disconnect PCM connector C2. Using DVOM, check continuity of A/C compressor cycling switch circuit between PCM and cycling switch (Dark Green wire). If continuity is indicated, go to next step. If continuity is not indicated, go to step 50).

27) Using DVOM, check continuity between A/C compressor cycling switch circuit and ground. If continuity is indicated, go to

step 51). If continuity is not indicated, go to step 54).

28) If A/C fuse (10 amp) is blown, go to step 52). If A/C fuse is okay, go to next step.

29) Remove A/C clutch relay from underhood electrical center. Using test light connected to battery voltage, probe A/C clutch relay ignition supply circuit on fuse side. If test light come on, go to step 52). If test light does not come on, go to next step.

30) Disconnect A/C compressor clutch connector. Using test light connected to battery voltage, probe A/C compressor clutch supply circuit terminal (Dark Green wire). If test light comes on, go to step 53). If test light does not come on, replace A/C compressor clutch.

31) Turn ignition switch to OFF position. Disconnect PCM connector C2. Using DVOM, check continuity of A/C relay control circuit between PCM and underhood electrical center (Dark Green/White wire). If continuity is indicated, go to step 54). If continuity is not indicated, go to step 56).

32) Repair open in circuit that did not turn test light on. Recheck system operation.

33) Repair open in A/C clutch circuit between relay and clutch. Recheck system operation.

34) Replace A/C clutch relay. Recheck system operation.

35) Check for proper terminal contact at A/C compressor clutch. If poor connection is found, repair as necessary and recheck system operation. If connections are okay, replace A/C compressor clutch. See appropriate COMPRESSOR SERVICING article in GENERAL SERVICING.

36) Repair open in A/C clutch ground circuit (Black wire). Recheck system operation.

37) Repair short to voltage in A/C request circuit (Dark Green/White wire) between A/C high pressure cut-out switch and PCM. Recheck system operation.

38) Repair short to voltage in circuit that had continuity. Recheck system operation.

39) Repair short to voltage in Dark Green wire between A/C clutch relay and A/C compressor clutch. Recheck system operation.

40) Replace A/C clutch relay. Recheck system operation.

41) Repair short to ground in Dark Green/White wire between A/C clutch relay and PCM. Recheck system operation.

42) Repair short to ground in circuit that had continuity. Recheck system operation.

43) Check for proper terminal contact at A/C high pressure cut-out switch. Repair as necessary and recheck system operation. If connections are okay, go to next step.

44) Replace A/C high pressure cut-out switch. Recheck system operation.

45) Repair open in Dark Green/White wire between A/C high pressure cut-out switch and PCM. Recheck system operation.

46) Repair short to ground in Dark Green/White wire between A/C high pressure cut-out switch and PCM. Recheck system operation.

47) Check for proper terminal contact at A/C compressor cycling switch. Repair as necessary and recheck system operation. If connections are okay, go to next step.

48) Replace A/C compressor cycling switch. Recheck system operation.

49) Repair open in A/C compressor cycling switch ground circuit (Black wire). Recheck system operation.

50) Repair open in A/C compressor cycling switch signal circuit (Dark Green wire). Recheck system operation.

51) Repair short to ground in A/C compressor cycling switch signal circuit (Dark Green wire). Recheck system operation.

52) Replace underhood electrical center. Recheck system operation.

53) Check for, and repair, short to ground in Dark Green

wire. If wire is okay, replace shorted A/C compressor clutch diode. Recheck system operation.

54) Check for proper terminal contact at PCM. Repair as necessary and recheck system operation. If connections are okay, go to next step.

55) Replace PCM and program. See appropriate REMOVAL, OVERHAUL & INSTALLATION article in ENGINE PERFORMANCE. Recheck system operation.

56) Repair open in A/C clutch relay control circuit (Dark Green/White wire) between underhood fuse block and PCM. Recheck system operation.

Diagnostic Aids

Intermittent conditions can be caused by poor connections, rubbed wire through insulation or a broken wire within the insulation. Check circuits thoroughly. For additional information, see appropriate MANUAL or AUTOMATIC A/C-HEATER SYSTEMS article.

5.0L & 5.7L: "C" & "K" SERIES (2000) 7.4L: "G" SERIES (2000)

NOTE: For circuit, wire color and terminal identification, see WIRING DIAGRAMS. Also see WIRING DIAGRAMS in appropriate MANUAL or AUTOMATIC A/C HEATER SYSTEMS article.

Description

Vehicle Control Module (VCM) control of A/C clutch improves idle quality and performance by performing the following conditions:

- * Delaying clutch engagement until idle speed is increased.
- * Releasing clutch when idle speed is too low.
- * Providing additional fuel at the instant clutch is applied. Additional fuel smooths cycling of compressor.

Turning air conditioning on supplies battery voltage through pressure switches to VCM. When VCM receives voltage on A/C request signal, A/C enable relay circuit is grounded. A/C compressor clutch then engages.

Diagnosis

1) Before using this table confirm A/C system has an adequate state of charge. If A/C system has an adequate state of charge, go to next step. If A/C system does not have an adequate state of charge, see CHARGING A/C SYSTEM in GENERAL SERVICING PROCEDURES article.

2) Start engine. Idle engine until normal operating temperature is reached. Leave engine at normal idle. Turn A/C on. If A/C clutch engages within 60 seconds, see DIAGNOSTIC AIDS. If A/C clutch does not engage within 60 seconds, go to next step.

3) Turn ignition switch to OFF position. Install scan tool. Start engine. Turn A/C on. Monitor A/C REQUEST in scan tool data list. If A/C REQUEST is YES, go to next step. If A/C REQUEST is not YES, go to step 14).

4) Using scan tool, monitor A/C EVAPORATOR SWITCH. If scan tool indicates switch is CLOSED, go to step 8). If scan tool does not indicate switch is CLOSED, go to next step.

5) Turn ignition switch to OFF position. Disconnect A/C cycling switch connector. Turn ignition switch to ON position, with engine off. Connect fused jumper between Dark Green wire at A/C cycling switch connector and ground. If scan tool indicates switch is CLOSED, go to next step. If scan tool does not indicate switch is CLOSED, go to step 27).

6) Using test light connected to battery voltage, probe Black/White wire of A/C cycling switch connector. If test light is on, go to next step. If test light is off, go to step 30).

7) Replace A/C cycling switch. After repairs, go to step 32).

CAUTION: Avoid contact with moving parts and hot surfaces while working around a running engine in order to prevent physical injury.

8) Turn ignition switch to OFF position. Disconnect A/C compressor clutch connector. Start engine. Turn A/C on. Using test light connected to ground, probe A/C clutch voltage supply circuit (Dark Green wire) at A/C compressor clutch connector. If test light is on, go to next step. If test light is off, go to step 16).

9) Using test light connected to battery voltage, probe A/C clutch ground circuit (Black wire) at A/C clutch connector. If test light is on, go to step 11). If test light is off, go to next step.

10) Repair A/C clutch ground circuit (Black wire). After repairs, go to step 32).

11) Check A/C compressor clutch connector for poor connections. If problem was found, go to next step. If problem was not found, go to step 13).

12) Repair A/C compressor clutch connector. After repairs, go to step 32).

13) Replace A/C compressor clutch. See appropriate COMPRESSOR SERVICING article in GENERAL SERVICING. After repairs, go to step 32).

14) Turn ignition switch to OFF position. Disconnect VCM connector C3. Turn ignition switch to ON position, with engine off. Turn A/C on. Using test light connected to ground, probe VCM connector C3 terminal No. 25 (Dark Green/White wire). If test light is on, go to step 29). If test light is off, go to next step.

15) Check A/C request signal circuit (Dark Green/White wire and Light Green wire) for open between HVAC control module and VCM. If problem was found, go to step 30). If problem was not found, go to step 28).

16) Reconnect A/C clutch connector. Install scan tool. Turn ignition switch to ON position, with engine off. Using scan tool, command A/C relay on. If A/C relay clicks, go to step 22). If A/C relay does not click, go to next step.

17) Disconnect A/C compressor clutch relay. Turn ignition switch to ON position, with engine off. Using test light connected to ground, probe ignition voltage circuit (Pink wire) at A/C relay connector. If test light is on, go to step 19). If test light is off, go to next step.

18) Repair open in A/C relay ignition voltage circuit (Pink wire). If fuse is blown, repair short to ground in Pink wire. After repairs, go to step 32).

19) Using test light connected to battery voltage, probe A/C relay control circuit (Dark Green/White wire) at A/C compressor clutch relay connector. Using scan tool, command A/C compressor clutch relay on. If test light is on, go to step 25). If test light is off, go to next step.

20) Check for open or short to voltage in Dark Green/White wire between underhood fuse block and VCM connector C3. If problem was found, go to next step. If problem was not found, go to step 29).

21) Repair Dark Green/White wire between underhood fuse block and VCM connector C3. After repairs, go to step 32).

22) Remove A/C compressor clutch relay. Using test light connected to ground, probe battery feed circuit (Orange wire) at A/C compressor clutch relay connector. If test light is on, go to step 24). If test light is off, go to next step.

23) Repair open in A/C compressor clutch relay battery feed circuit. If fuse is blown, repair short to ground in Orange wire. After repairs, go to step 32).

24) Turn ignition switch to ON position, with engine off. Using fused jumper wire, connect battery feed circuit and A/C

compressor clutch voltage supply circuit (Dark Green wire) at A/C compressor clutch relay connector. If A/C clutch engages, go to next step. If A/C clutch does not engage, go to step 26).

25) Replace A/C compressor clutch relay. After repairs, go to step 32).

26) Repair open or short to ground in A/C compressor clutch voltage supply circuit (Dark Green wire). After repairs, go to step 32).

27) Check for open in A/C cycling switch signal circuit (Dark Green wire). If problem was found, go to step 30). If problem was not found, go to step 29).

28) Replace HVAC control assembly. See REMOVAL & INSTALLATION in appropriate MANUAL A/C-HEATER SYSTEMS article. After repairs, go to step 32).

29) Check VCM connectors for poor connections. If problem was found, go to next step. If problem was not found, go to step 31).

30) Repair circuit as necessary. After repairs, go to step 32).

31) Replace VCM. See appropriate REMOVAL, OVERHAUL & INSTALLATION article in ENGINE PERFORMANCE. After repairs, go to next step.

32) Start engine. Idle engine until normal operating temperature is reached. Leave engine at normal idle. Turn A/C on. A/C clutch should engage within 60 seconds. Using scan tool, check for DTCs. If DTCs are not present, system is okay.

Diagnostic Aids

Intermittent conditions can be caused by poor connections, rubbed wire through insulation or a broken wire within the insulation. Check circuits thoroughly. For additional information, see appropriate MANUAL A/C-HEATER SYSTEMS article.

6.5L: "C" & "K" SERIES (2000)

NOTE: For circuit, wire color and terminal identification, see WIRING DIAGRAMS. Also see WIRING DIAGRAMS in appropriate MANUAL or AUTOMATIC A/C HEATER SYSTEMS article.

HVAC Compressor Controls System Check

1) Start vehicle. Turn blower switch to HIGH position. Turn A/C on. A/C compressor clutch engages. If cold air comes from air vents, system is okay. If air from vents does not get cold, see COMPRESSOR CLUTCH DOES NOT ENGAGE.

2) Turn A/C off, leave blower on high. A/C compressor clutch should disengage. If cool air from vents turns warm after a few minutes, system is okay. If air remains cool coming from vents, see COMPRESSOR CLUTCH DOES NOT DISENGAGE.

Compressor Clutch Does Not Engage

1) Ensure A/C system has sufficient refrigerant charge. If refrigerant charge is sufficient, go to next step. If refrigerant charge is not sufficient, see CHARGING A/C SYSTEM in GENERAL SERVICING PROCEDURES article.

2) Disconnect PCM connector C3. Connect fused jumper wire between VCM connector C3 terminal D5 (Dark Green/White wire) and ground. Turn ignition switch to ON position. If audible click from A/C compressor clutch is heard, go to step 14). If audible click from A/C compressor clutch is not heard, go to next step.

3) Remove A/C compressor clutch relay. Connect fused jumper wire between A/C compressor clutch relay connector terminals B4 (Orange wire) and A6 (Dark Green wire). If clutch engages, go to next step. If clutch does not engage, go to step 7).

4) Disconnect PCM connector C3. Connect fused jumper wire

between A/C compressor clutch relay terminals A4 (Pink wire) and B6 (Dark Green/White wire). Using DVOM, measure voltage between PCM connector C3 terminal D5 (Dark Green/White wire) and ground. Turn ignition switch to ON position. If battery voltage is present, go to next step. If battery voltage is not present, go to step 6).

5) Replace A/C compressor clutch relay. After repairs, recheck system operation.

6) Repair open in Dark Green wire between underhood fuse block and PCM. After repairs, recheck system operation.

7) Disconnect A/C compressor clutch connector. Using DVOM, check continuity between A/C compressor clutch connector terminal "A" (Black wire) and ground. If continuity exists, go to step 9). If continuity does not exist, go to next step.

8) Repair open in Black wire between compressor clutch and ground. After repairs, recheck system operation.

9) Connect fused jumper wire between A/C compressor clutch relay connector terminals B4 (Orange wire) and A6 (Dark Green wire). Using DVOM, measure voltage between terminals of compressor clutch connector. If battery voltage is present, go to step 11). If battery voltage is not present, go to next step.

10) Repair open in Dark Green wire between underhood fuse block and compressor clutch connector. After repairs, recheck system operation.

11) Remove fused jumper wire between at A/C compressor clutch relay connector. Using DVOM, check continuity between compressor clutch connector terminals. Reverse meter leads at connector and check continuity again. If continuity is present in one direction only, go to step 13). If continuity is not present in one direction only, go to next step.

12) Replace diode located within A/C compressor clutch harness. After repairs, recheck system operation.

13) Replace A/C compressor clutch. See appropriate COMPRESSOR SERVICING article in GENERAL SERVICING. After repairs, recheck system operation.

14) Disconnect A/C compressor cycling switch. Connect jumper between A/C compressor cycling switch connector terminals. Using DVOM, measure voltage between PCM connector C1 terminal C2 (Dark Green wire) and ground. Turn ignition switch to ON position. Turn front blower switch to any position except OFF. Push in A/C Button. If battery voltage is present, go to next step. If battery voltage is not present, go to step 16).

15) Replace A/C compressor cycling switch. After repairs, recheck system operation.

16) Disconnect A/C high pressure switch connector. Connect fused jumper wire between A/C high pressure switch connectors. Using DVOM, measure voltage between PCM connector C1 terminal C2 (Dark Green wire) and ground. Turn ignition switch to ON position. Turn front blower switch to any position except OFF. Push in A/C Button. If battery voltage is present, go to next step. If battery voltage is not present, go to step 18).

17) Replace A/C high pressure switch. After repairs, recheck system operation.

18) Disconnect HVAC control module connector C3. Connect fused jumper between HVAC control module connector C3 terminals No. 5 (Brown wire) and No. 10 (Light Green wire). Using DVOM, measure voltage between PCM connector C1 terminal C2 (Dark Green/White) and ground. Turn ignition switch to ON position. Turn front blower switch to any position except OFF. Push in A/C Button. If battery voltage is present, go to next step. If battery voltage is not present, go to step 20).

19) Replace HVAC control module. See REMOVAL & INSTALLATION in appropriate MANUAL A/C-HEATER SYSTEMS article. After repairs, recheck system operation.

20) Repair open in Brown wire, Light Green wire, Dark Green wire or Dark Green/White wire between instrument panel fuse block and PCM. After repairs, recheck system operation.

Compressor Clutch Does Not Disengage

1) If HVAC compressor controls system check has been performed, go to next step. If HVAC compressor controls system check has not been performed, see HVAC COMPRESSOR CONTROLS SYSTEM CHECK.

2) Turn ignition switch to ON position. Remove A/C Compressor Clutch Relay. If A/C compressor clutch disengages, go to step 6). If A/C compressor clutch does not disengage, go to next step.

3) Using DVOM, measure voltage between A/C compressor clutch relay connector terminal A6 (Dark Green wire) and ground. If voltage is greater than 0.5 volt, go to next step. If voltage is not greater than 0.5 volts, go to step 5).

4) Repair short to battery voltage in Dark Green wire between A/C compressor clutch relay and A/C compressor clutch. After repairs, perform HVAC COMPRESSOR CONTROLS SYSTEM CHECK.

5) Replace A/C compressor clutch. See appropriate COMPRESSOR SERVICING article in GENERAL SERVICING. After repairs, perform HVAC COMPRESSOR CONTROLS SYSTEM CHECK.

6) Connect fused jumper between A/C compressor clutch relay connector terminal A4 (Pink wire) and battery voltage. Connect second jumper between A/C compressor clutch relay connector terminal B6 (Dark Green/White wire) and ground. If relay clicks, go to step 8).

7) Replace A/C Compressor Clutch Relay. After repairs, perform HVAC COMPRESSOR CONTROLS SYSTEM CHECK.

8) Turn ignition switch to OFF position. Using DVOM, measure continuity between A/C compressor clutch relay connector terminal B6 (Dark Green/White wire) and ground. If continuity is present, go to next step. If continuity does not exist, go to step 10).

9) Repair short to ground in Dark Green/White wire between A/C compressor clutch relay and PCM. After repairs, perform HVAC COMPRESSOR CONTROLS SYSTEM CHECK.

10) Turn ignition switch to ON position. Disconnect HVAC Control Module connector C3. Using DVOM, measure voltage between PCM connector C1 terminal C2 (Dark Green/White wire) and ground. If battery voltage is present, go to step 12). If battery voltage is not present, go to next step.

11) Replace HVAC control module. See REMOVAL & INSTALLATION in appropriate MANUAL A/C-HEATER SYSTEMS article. After repairs, perform HVAC COMPRESSOR CONTROLS SYSTEM CHECK.

12) Repair short to battery voltage in Light Green wire, Dark Green wire or Dark Green/White wire between HVAC control module and PCM. After repairs, perform HVAC COMPRESSOR CONTROLS SYSTEM CHECK.

4.3L, 4.8L, 5.3L, 6.0L, 6.6L & 8.1L: "C" & "K" SERIES

(AUTOMATIC A/C 2001)

NOTE: For circuit, wire color and terminal identification, see WIRING DIAGRAMS. Also see WIRING DIAGRAMS in appropriate MANUAL or AUTOMATIC A/C HEATER SYSTEMS article.

Description

A/C system can operate regardless of temperature setting, as long as outside ambient temperature is greater than 40°F (4°C). If A/C is requested and temperatures are too low, LED will flash 3 times to remind vehicle operator that A/C is not available.

Regardless of selected A/C mode setting, a request is made to Powertrain Control Module (PCM) to turn on A/C compressor. request is sent to PCM through A/C request signal circuit from HVAC control module. Power and ground are provided to HVAC control module by fuse

block through ignition voltage and ground circuits.

In order for PCM to internally ground A/C clutch relay control circuit, 2 separate request signals need to be grounded. A 12-volt reference signal is sent out over A/C request signal circuits, through A/C high pressure switch and grounded through HVAC control module when vehicle operator makes an A/C request. A separate 12-volt reference signal is sent out over A/C refrigerant low pressure cut-out switch signal circuit, through A/C low pressure switch and ground circuit. When both these reference signals are grounded, PCM can activate A/C compressor clutch.

PCM turns on A/C compressor by providing a path to ground through A/C clutch relay control circuit for A/C compressor clutch relay. Power is provided to A/C compressor clutch relay internally of engine wiring harness junction block. Once relay closes its internal switch, power from battery is provided to A/C compressor clutch through A/C compressor clutch supply voltage circuit. Whenever compressor is turned off, A/C compressor clutch diode provides a path for voltage spike resulting from collapsing magnetic field of compressor clutch coil. Ground circuit provides a pathway to ground for compressor. A/C clutch relay control circuit is grounded internally within PCM.

A/C system is protected by 2 pressure switches. A/C high pressure switch interrupts A/C request signal when A/C line pressure exceeds a predetermined value. A/C low pressure switch interrupts A/C refrigerant low pressure cut-out switch signal when A/C line pressure falls less than 21-25 psi (1.5-1.8 kg/cm²). When PCM sees an open in either signal, A/C clutch relay control circuit is no longer grounded, thus shutting off compressor. Low pressure switch will close when pressure reaches 38-42 psi (2.7-3.0 kg/cm²).

Diagnostic System Check

1) Install scan tool. If scan tool powers up, go to next step. If scan tool does not power up, see SCAN TOOL DOES NOT POWER UP in appropriate BODY CONTROL MODULES article.

2) Turn ignition on, engine off. Try to establish scan tool communication with HVAC control module, Body Control Module (BCM) and Powertrain Control Module (PCM)/Vehicle Control Module (VCM). If communication with all modules is established, go to next step. If communication with all modules is not established, see SCAN TOOL DOES NOT COMMUNICATE WITH CLASS 2 DEVICE in appropriate BODY CONTROL MODULES article.

3) Select display DTC function for each module. Record all displayed DTCs, status of displayed DTCs and which module set DTCs. If DTCs are displayed, go to next step. If no DTCs are displayed, see COMPRESSOR CLUTCH DOES NOT ENGAGE or COMPRESSOR CLUTCH DOES NOT DISENGAGE.

4) If scan tool displays DTCs beginning with "B", see appropriate SELF-DIAGNOSTICS article in BODY CONTROL MODULES. If scan tool displays DTCs beginning with "P", see appropriate SELF-DIAGNOSTICS article in ENGINE PERFORMANCE. If scan tool displays DTCs beginning with "U", see SCAN TOOL DOES NOT COMMUNICATE WITH CLASS 2 DEVICE in appropriate BODY CONTROL MODULES article.

Compressor Clutch Does Not Engage

1) If diagnostic system check has not been performed, see DIAGNOSTIC SYSTEM CHECK. If diagnostic system check has been performed, go to next step.

2) Ensure outside air temperature is greater than 40°F (4°C). Start engine. Turn blower motor switch to maximum speed position. Place A/C switch in ON position. Place air temperature control switch

in coldest position. If A/C compressor operates, problem is intermittent. If A/C compressor does not operate, go to next step.

3) Park vehicle inside or in shade. Open windows in order to ventilate interior of vehicle. If A/C system was operating, then allow A/C system to equalize for about 2 minutes. Turn ignition switch to OFF position. Install Refrigerant Station (J 43600 ACR 2000). Record outside air temperature at vehicle. Record readings of low and high side static pressures. Compare pressure values with specifications for ambient air temperature. See PRESSURE-TEMPERATURE RELATIONSHIP article in GENERAL SERVICING. If pressure values are within specification for ambient air temperature and within 15 psi (1.1 kg/cm²) of each other, go to next step. If pressure values are not within specification for ambient air temperature or within 15 psi (1.1 kg/cm²) of each other, see LEAK TESTING article in GENERAL SERVICING.

4) If HVAC control module is inoperative, go to step 19). If HVAC control module is not inoperative, go to next step.

5) Start engine. Using scan tool, observe A/C REQUEST SIGNAL parameter. Place A/C request switch in ON position. If scan tool indicates A/C REQUEST SIGNAL parameter is YES, go to step 8). If scan tool does not indicate A/C REQUEST SIGNAL parameter is YES, go to next step.

6) If A/C request indicator is on, go to next step. If A/C request indicator is not on, go to step 30).

7) Turn ignition switch to OFF position. Disconnect A/C high pressure switch. Connect fused jumper (3 amp) between A/C high pressure switch connector terminals. Start engine. Using scan tool, observe A/C REQUEST SIGNAL parameter. Place A/C request switch in ON position. If scan tool indicates A/C REQUEST SIGNAL parameter is YES, go to step 31). If scan tool does not indicate A/C REQUEST SIGNAL parameter is YES, go to step 25).

8) If scan tool indicates A/C COMPRESSOR CYCLING SWITCH parameter is NORMAL, go to step 10). If scan tool does not indicate A/C COMPRESSOR CYCLING SWITCH parameter is NORMAL, go to next step.

9) Turn ignition switch to OFF position. Disconnect A/C low pressure switch. Connect fused jumper (3 amp) between A/C low pressure switch connector terminals. Start engine. Using scan tool, observe A/C COMPRESSOR CYCLING SWITCH parameter. If scan tool indicates A/C COMPRESSOR CYCLING SWITCH parameter is NORMAL, go to step 28). If scan tool does not indicate A/C COMPRESSOR CYCLING SWITCH parameter is NORMAL, go to step 21).

10) Using scan tool, command A/C compressor clutch relay on and off. If A/C compressor clutch relay turns on and off with each command, go to step 16). If A/C compressor clutch relay does not turn on and off with each command, go to next step.

11) Turn ignition switch to OFF position. Disconnect A/C compressor clutch relay. Turn ignition switch to ON position, with engine off. Using test light connected to ground, probe coil side voltage supply circuit of A/C compressor clutch relay. If test light is on, go to next step. If test light is off, go to step 26).

12) Connect test light between control circuit (Dark Green/White wire) of A/C compressor clutch relay and coil side voltage supply circuit of A/C compressor clutch relay. Using scan tool, command A/C compressor clutch relay on and off. If test light turns on and off with each command, go to step 27). If test light does not turn on and off with each command, go to next step.

13) If test light remains on with each command, go to step 15). If test light does not remain on with each command, go to next step.

14) Check control circuit (Dark Green/White wire) of A/C compressor clutch relay for open. If problem was found, repair as necessary. After repairs, go to step 39). If problem was not found, go to step 32).

15) Check control circuit (Dark Green/White wire) of A/C

compressor clutch relay for short to ground. If problem was found, repair as necessary. After repairs, go to step 39). If problem was not found, go to step 32).

16) Turn ignition switch to OFF position. Disconnect A/C compressor clutch relay. Using test light connected to ground, probe switch side voltage supply circuit of A/C compressor clutch relay. If test light is on, go to next step. If test light is off, go to step 18).

17) Connect fused jumper (10 amp) between switch side voltage circuit of A/C compressor clutch relay and A/C compressor clutch supply voltage circuit (Dark Green wire) of A/C compressor clutch. Turn ignition switch to ON position, with engine off. If A/C compressor clutch engages, go to step 27). If A/C compressor clutch does not engage, go to step 23).

18) Repair switch side voltage supply circuit of A/C compressor clutch relay. After repairs, go to step 39).

19) Check ignition voltage circuit (Brown wire) of HVAC control module for short to ground, high resistance, or open. If problem was found, repair as necessary. After repairs, go to step 39). If problem was not found, go to next step.

20) Check ground circuit (Black wire) of HVAC control module for open. If problem was found, repair as necessary. After repairs, go to step 39). If problem was not found, go to step 30).

21) Check A/C low pressure switch signal circuit (Dark Green wire) for high resistance or open. If problem was found, repair as necessary. After repairs, go to step 39). If problem was not found, go to next step.

22) Check ground circuit (Black wire) of A/C low pressure switch for high resistance or open. If problem was found, repair as necessary. After repairs, go to step 39). If problem was not found, go to step 32).

23) Check A/C compressor clutch supply voltage circuit (Dark Green wire) at A/C compressor clutch for short to ground, high resistance or open. If problem was found, repair as necessary. After repairs, go to step 39). If problem was not found, go to next step.

24) Check ground circuit (Black wire) of A/C compressor clutch for high resistance or open. If problem was found, repair as necessary. After repairs, go to step 39). If problem was not found, go to step 29).

25) Turn ignition switch to OFF position. Reconnect A/C high pressure switch. Check A/C request signal circuit (Light Blue wire and Dark Green/White wire) for short to ground, high resistance or open. If problem was found, repair as necessary. After repairs, go to step 39). If problem was not found, go to step 32).

26) Repair coil side voltage supply circuit of A/C compressor clutch relay. After repairs, go to step 39).

27) Check A/C compressor clutch relay connector for poor connections. If problem was found, repair as necessary. After repairs, go to step 39). If problem was not found, go to step 33).

28) Check A/C low pressure switch connector for poor connections. If problem was found, repair as necessary. After repairs, go to step 39). If problem was not found, go to step 34).

29) Check A/C compressor clutch connector for poor connections. If problem was found, repair as necessary. After repairs, go to step 39). If problem was not found, go to step 36).

30) Check HVAC control module connector for poor connections. If problem was found, repair as necessary. After repairs, go to step 39). If problem was not found, go to step 37).

31) Check A/C high pressure switch connector for poor connections. If problem was found, repair as necessary. After repairs, go to step 39). If problem was not found, go to step 35).

32) Check PCM connectors for poor connections. If problem was found, repair as necessary. After repairs, go to step 39). If problem

was not found, go to step 38).

33) Replace A/C compressor clutch relay. After repairs, go to step 39).

34) Replace A/C low pressure switch. After repairs, go to step 39).

35) Replace A/C high pressure switch. After repairs, go to step 39).

36) Replace A/C compressor clutch coil. See appropriate COMPRESSOR SERVICING article in GENERAL SERVICING. After repairs, go to step 39).

37) Replace HVAC control module. See REMOVAL & INSTALLATION in appropriate MANUAL A/C-HEATER SYSTEMS article. After repairs, go to step 39).

38) Replace PCM. See appropriate REMOVAL, OVERHAUL & INSTALLATION article in ENGINE PERFORMANCE. After repairs, go to next step.

39) Operate system to verify repair.

Compressor Clutch Does Not Disengage

1) If diagnostic system check has not been performed, see DIAGNOSTIC SYSTEM CHECK. If diagnostic system check has been performed, go to next step.

2) Start engine. Place blower motor switch in OFF position. Place A/C request switch in OFF position. If A/C compressor operates, go to next step. If A/C compressor does not operate, problem is intermittent.

3) Using scan tool, observe A/C REQUEST SIGNAL parameter in POWERTRAIN data list. If scan tool indicates A/C REQUEST SIGNAL parameter is YES, go to next step. If scan tool does not indicate A/C REQUEST SIGNAL parameter is YES, go to step 6).

4) Check A/C request signal circuit (Light Blue wire and Dark Green/White wire) for short to ground. If problem was found, repair as necessary. After repairs, go to step 17). If problem was not found, go to next step.

5) Turn ignition switch to off position. Disconnect A/C high pressure switch. Start engine. Using scan tool, observe A/C REQUEST SIGNAL parameter. If scan tool indicates A/C REQUEST SIGNAL parameter is YES, go to step 12). If scan tool does not indicate A/C REQUEST SIGNAL parameter is YES, go to step 11).

6) Remove A/C compressor clutch relay. If A/C compressor clutch turns off, go to next step. If A/C compressor clutch does not turn off, go to step 9).

7) Measure resistance between switch side A/C compressor clutch relay terminals. If resistance is infinite, go to next step. If resistance is not infinite, go to step 10).

8) Check A/C compressor clutch relay control circuit (Dark Green/White wire) for short to ground. If problem was found, repair as necessary. After repairs, go to step 17). If problem was not found, go to step 12).

9) Check A/C compressor clutch supply voltage circuit (Dark Green wire) for short to voltage. If problem was found, repair as necessary. After repairs, go to step 17). If problem was not found, go to step 14).

10) Check A/C compressor clutch relay connector for poor connections. If problem was found, repair as necessary. After repairs, go to step 17). If problem was not found, go to step 13).

11) Check HVAC control module for poor connections. If problem was found, repair as necessary. After repairs, go to step 17). If problem was not found, go to step 15).

12) Check PCM connectors for poor connections. If problem was found, repair as necessary. After repairs, go to step 17). If problem was not found, go to step 16).

13) Replace A/C compressor clutch relay. After repairs, go to

step 17).

14) Replace A/C compressor clutch. See appropriate COMPRESSOR SERVICING article in GENERAL SERVICING. After repairs, go to step 17).

15) Replace HVAC control module. See REMOVAL & INSTALLATION in appropriate MANUAL A/C-HEATER SYSTEMS article. After repairs, go to step 17).

16) Replace PCM. See appropriate REMOVAL, OVERHAUL & INSTALLATION article in ENGINE PERFORMANCE. After repairs, go to next step.

17) Operate system to verify repair.

4.3L, 4.8L, 5.3L, 6.0L, 6.6L & 8.1L: "C" & "K" SERIES (MANUAL A/C 2001)

NOTE: For circuit, wire color and terminal identification, see WIRING DIAGRAMS. Also see WIRING DIAGRAMS in appropriate MANUAL or AUTOMATIC A/C HEATER SYSTEMS article.

Description

A/C system can operate regardless of temperature setting, however, recirculation is only available when HVAC control module is either in A/C or BI-LEVEL mode. Regardless of selected A/C mode setting, a request is made to Powertrain Control Module (PCM) to turn on A/C compressor. Request is sent to PCM through A/C request signal circuit from HVAC control module. Power and ground are provided to HVAC control module by left instrument panel fuse block through ignition voltage and ground circuits.

In order for PCM to internally ground A/C clutch relay control circuit, 2 separate request signals need to be grounded. A 12 volt reference signal is sent out over A/C request signal circuits, through A/C high pressure switch and grounded through HVAC control module when vehicle operator makes an A/C request. A separate 12 volt reference signal is sent out over A/C refrigerant low pressure cut-out switch signal circuit, through A/C low pressure switch and ground circuit. When both these reference signals are grounded, PCM can activate A/C compressor clutch.

PCM turns on A/C compressor by providing a path to ground through A/C clutch relay control circuit for A/C compressor clutch relay. Power is provided to A/C compressor clutch relay internally of engine wiring harness junction block. Once relay closes its internal switch, power from battery is provided to A/C compressor clutch through A/C compressor clutch supply voltage circuit. Whenever compressor is turned off, A/C compressor clutch diode prevents a voltage spike from entering vehicles electrical system. Ground circuit provides a pathway to ground for compressor. A/C clutch relay control circuit is grounded internally within PCM.

A/C system is protected by 2 pressure switches. A/C high pressure switch interrupts A/C request signal when A/C line pressure exceeds a predetermined value. A/C low pressure switch interrupts A/C refrigerant low pressure cut-out switch signal when A/C line pressure falls less than 21-25 psi (1.5-1.8 kg/cm²). When PCM sees an open in either signal, A/C clutch relay control circuit is no longer grounded, thus shutting off compressor. Low pressure switch will close when pressure reaches 38-42 psi (2.7-3.0 kg/cm²).

Compressor Clutch Does Not Engage

1) Ensure outside air temperature is greater than 40°F (4°C). Start engine. Turn blower motor switch to maximum speed position. Place A/C switch in ON position. Place air temperature control switch in coldest position. If A/C compressor operates, problem is

intermittent. If A/C compressor does not operate, go to next step.

2) Park vehicle inside or in shade. Open windows in order to ventilate interior of vehicle. If A/C system was operating, then allow A/C system to equalize for about 2 minutes. Turn ignition switch to OFF position. Install Refrigerant Station (J 43600 ACR 2000). Record outside air temperature at vehicle. Record readings of low and high side static pressures. Compare pressure values with specifications for ambient air temperature. See PRESSURE-TEMPERATURE RELATIONSHIP article in GENERAL SERVICING. If pressure values are within specification for ambient air temperature and within 15 psi (1.1 kg/cm²) of each other, go to next step. If pressure values are not within specification for ambient air temperature or within 15 psi (1.1 kg/cm²) of each other, see LEAK TESTING article in GENERAL SERVICING.

3) If HVAC control module is inoperative, go to step 18). If HVAC control module is not inoperative, go to next step.

4) Start engine. Using scan tool, observe A/C REQUEST SIGNAL parameter. Place A/C request switch in ON position. If scan tool indicates A/C REQUEST SIGNAL parameter is YES, go to step 7). If scan tool does not indicate A/C REQUEST parameter is YES, go to next step.

5) If A/C request indicator is on, go to next step. If A/C request indicator is not on, go to step 20).

6) Ensure blower motor switch is not in OFF position. Turn ignition switch to OFF position. Disconnect A/C high pressure switch. Connect fused jumper (3 amp) between A/C high pressure switch connector terminals. Start engine. Using scan tool, observe A/C REQUEST SIGNAL parameter. Place A/C request switch in ON position. If scan tool indicates A/C REQUEST SIGNAL parameter is YES, go to step 31). If scan tool does not indicate A/C REQUEST SIGNAL parameter is YES, go to step 25).

7) If scan tool indicates A/C COMPRESSOR CYCLING SWITCH parameter is CLOSED, go to step 9). If scan tool does not indicate A/C COMPRESSOR CYCLING SWITCH parameter is CLOSED, go to next step.

8) Turn ignition switch to OFF position. Disconnect A/C low pressure switch. Connect fused jumper (3 amp) between A/C low pressure switch signal circuit (Dark Green wire) and ground. Start engine. Using scan tool, observe A/C COMPRESSOR CYCLING SWITCH parameter. If scan tool indicates A/C COMPRESSOR CYCLING SWITCH parameter is NORMAL, go to step 28). If scan tool does not indicate A/C COMPRESSOR CYCLING SWITCH parameter is NORMAL, go to step 21).

9) Using scan tool, command A/C compressor clutch relay on and off. If A/C compressor clutch relay turns on and off with each command, go to step 15). If A/C compressor clutch relay does not turn on and off with each command, go to next step.

10) Turn ignition switch to OFF position. Disconnect A/C compressor clutch relay. Turn ignition switch to ON position, with engine off. Using test light connected to ground, probe coil side voltage supply circuit of A/C compressor clutch relay. If test light is on, go to next step. If test light is off, go to step 26).

11) Connect test light between control circuit (Dark Green/White wire) of A/C compressor clutch relay and coil side voltage supply circuit of A/C compressor clutch relay. Using scan tool, command A/C compressor clutch relay on and off. If test light turns on and off with each command, go to step 27). If test light does not turn on and off with each command, go to next step.

12) If test light remains on with each command, go to step 14). If test light does not remain on with each command, go to next step.

13) Check control circuit (Dark Green/White wire) of A/C compressor clutch relay for open. If problem was found, repair as necessary. After repairs, go to step 39). If problem was not found, go to step 32).

14) Check control circuit (Dark Green/White wire) of A/C compressor clutch relay for short to ground. If problem was found,

repair as necessary. After repairs, go to step 39). If problem was not found, go to step 32).

15) Turn ignition switch to OFF position. Disconnect A/C compressor clutch relay. Using test light connected to ground, probe switch side voltage supply circuit of A/C compressor clutch relay. If test light is on, go to next step. If test light is off, go to step 17).

16) Connect fused jumper (10 amp) between switch side voltage circuit of A/C compressor clutch relay and A/C compressor clutch supply voltage circuit (Dark Green wire) of A/C compressor clutch. Turn ignition switch to ON position, with engine off. If A/C compressor clutch engages, go to step 27). If A/C compressor clutch does not engage, go to step 23).

17) Repair switch side voltage supply circuit of A/C compressor clutch relay. After repairs, go to step 39).

18) Check ignition voltage circuit (Brown wire) of HVAC control module for short to ground, high resistance, or open. If problem was found, repair as necessary. After repairs, go to step 39). If problem was not found, go to next step.

19) Check ground circuit (Black wire) of HVAC control module for open. If problem was found, repair as necessary. After repairs, go to step 39). If problem was not found, go to step 30).

20) Ensure that blower motor switch is not in OFF position. Check off blower motor control circuit (Dark Green wire) for short to voltage. If problem was found, repair as necessary. After repairs, go to step 39). If problem was not found, go to step 30).

21) Check A/C low pressure switch signal circuit (Dark Green wire) for high resistance or open. If problem was found, repair as necessary. After repairs, go to step 39). If problem was not found, go to next step.

22) Check ground circuit (Black wire) of A/C low pressure switch for high resistance or open. If problem was found, repair as necessary. After repairs, go to step 39). If problem was not found, go to step 32).

23) Check A/C compressor clutch supply voltage circuit (Dark Green wire) at A/C compressor clutch for short to ground, high resistance, or open. If problem was found, repair as necessary. After repairs, go to step 39). If problem was not found, go to next step.

24) Check ground circuit (Black wire) of A/C compressor clutch for high resistance or open. If problem was found, repair as necessary. After repairs, go to step 39). If problem was not found, go to step 29).

25) Turn ignition switch to OFF position. Reconnect A/C high pressure switch. Check A/C request signal circuit (Light Blue wire and Dark Green/White wire) for short to ground, high resistance or open. If problem was found, repair as necessary. After repairs, go to step 39). If problem was not found, go to step 32).

26) Repair coil side voltage supply circuit of A/C compressor clutch relay. After repairs, go to step 39).

27) Check A/C compressor clutch relay connector for poor connections. If problem was found, repair as necessary. After repairs, go to step 39). If problem was not found, go to step 33).

28) Check A/C low pressure switch connector for poor connections. If problem was found, repair as necessary. After repairs, go to step 39). If problem was not found, go to step 34).

29) Check A/C compressor clutch connector for poor connections. If problem was found, repair as necessary. After repairs, go to step 39). If problem was not found, go to step 36).

30) Check HVAC control module connector for poor connections. If problem was found, repair as necessary. After repairs, go to step 39). If problem was not found, go to step 37).

31) Check A/C high pressure switch connector for poor connections. If problem was found, repair as necessary. After repairs,

go to step 39). If problem was not found, go to step 35).

32) Check PCM connectors for poor connections. If problem was found, repair as necessary. After repairs, go to step 39). If problem was not found, go to step 38).

33) Replace A/C compressor clutch relay. After repairs, go to step 39).

34) Replace A/C low pressure switch. After repairs, go to step 39).

35) Replace A/C high pressure switch. After repairs, go to step 39).

36) Replace A/C compressor clutch coil. See appropriate COMPRESSOR SERVICING article in GENERAL SERVICING. After repairs, go to step 39).

37) Replace HVAC control module. See REMOVAL & INSTALLATION in appropriate MANUAL A/C-HEATER SYSTEMS article. After repairs, go to step 39).

38) Replace PCM. See appropriate REMOVAL, OVERHAUL & INSTALLATION article in ENGINE PERFORMANCE. After repairs, go to next step.

39) Operate system to verify repair.

Compressor Clutch Does Not Disengage

1) Start engine. Place blower motor switch in OFF position. Place A/C request switch in OFF position. If A/C compressor operates, go to next step. If A/C compressor clutch does not operate, problem is intermittent.

2) Using scan tool, observe A/C REQUEST SIGNAL parameter in POWERTRAIN data list. If scan tool indicates A/C REQUEST SIGNAL parameter is YES, go to next step. If scan tool does not indicate A/C REQUEST SIGNAL parameter is YES, go to step 5).

3) Check A/C request signal circuit (Light Blue wire and Dark Green/White wire) for short to ground. If problem was found, repair as necessary. After repairs, go to step 16). If problem was not found, go to next step.

4) Turn ignition switch to OFF position. Disconnect A/C high pressure switch. Start engine. Using scan tool, observe A/C REQUEST SIGNAL parameter. If scan tool indicates A/C REQUEST SIGNAL parameter is YES, go to step 11). If scan tool does not indicate A/C REQUEST SIGNAL parameter is YES, go to step 10).

5) Remove A/C compressor clutch relay. If A/C compressor clutch turns off, go to next step. If A/C compressor clutch does not turn off, go to step 8).

6) Measure resistance between switch side A/C compressor clutch relay terminals. If resistance is infinite, go to next step. If resistance is not infinite, go to step 9).

7) Check A/C clutch relay control circuit (Dark Green/White wire) for short to ground. If problem was found, repair as necessary. After repairs, go to step 16). If problem was not found, go to step 11).

8) Check A/C compressor clutch supply voltage circuit (Dark Green wire) for short to voltage. If problem was found, repair as necessary. After repairs, go to step 16). If problem was not found, go to step 13).

9) Check A/C compressor clutch relay connector for poor connections. If problem was found, repair as necessary. After repairs, go to step 16). If problem was not found, go to step 12).

10) Check HVAC control module connector for poor connections. If problem was found, repair as necessary. After repairs, go to step 16). If problem was not found, go to step 14).

11) Check PCM connectors for poor connections. If problem was found, repair as necessary. After repairs, go to step 16). If problem was not found, go to step 15).

12) Replace A/C compressor clutch relay. After repairs, go to

step 16).

13) Replace A/C compressor clutch. See appropriate COMPRESSOR SERVICING article in GENERAL SERVICING. After repairs, go to step 16).

14) Replace HVAC control module. See REMOVAL & INSTALLATION in appropriate MANUAL A/C-HEATER SYSTEMS article. After repairs, go to step 16).

15) Replace PCM. See appropriate REMOVAL, OVERHAUL & INSTALLATION article in ENGINE PERFORMANCE. After repairs, go to next step.

16) Operate system to verify repair.

4.3L, 5.0L, 5.7L, 6.5L & 8.1L: "G" SERIES (2001)

NOTE: For circuit, wire color and terminal identification, see WIRING DIAGRAMS. Also see WIRING DIAGRAMS in appropriate MANUAL or AUTOMATIC A/C HEATER SYSTEMS article.

Description

A/C system can operate regardless of air temperature setting. Regardless of selected A/C mode setting, a request is made to Powertrain Control Module (PCM) to turn on A/C compressor clutch. Request is sent to PCM through A/C request signal circuit and A/C high pressure switch from HVAC control assembly. On vehicles equipped with diesel engine, A/C request is sent to PCM through the A/C request signal circuit and A/C high and low pressure switches from HVAC control assembly. Power and ground are provided to HVAC control assembly by ignition voltage and ground circuits.

PCM turns on A/C compressor by providing a path to ground through A/C compressor clutch relay control circuit for A/C compressor clutch relay. Ignition voltage circuit provides power to A/C compressor clutch relay control. Once relay contact closes its internal switch, power from battery positive voltage circuit is provided to A/C compressor clutch through A/C compressor clutch supply voltage circuit. Whenever compressor is turned off, A/C clutch diode prevents a voltage spike from damaging compressor clutch coil. Ground circuit provides a pathway to ground for compressor and diode. Both A/C request signal and A/C clutch relay control circuits are grounded by ground circuits.

A/C system is protected by 2 pressure switches. A/C high pressure switch interrupts A/C request signal when A/C line pressure exceeds a predetermined value. A/C low pressure switch interrupts A/C low pressure switch signal when A/C line pressure drops below a predetermined value. When PCM stops receiving the required signals, A/C compressor clutch relay control circuit is no longer grounded, thus shutting off compressor.

Compressor Clutch Does Not Engage (Without 6.5L)

1) Ensure outside air temperature is greater than 3°C (38°F). Start engine. Turn blower motor switch to maximum speed position. Place A/C request switch in ON position. Place air temperature control switch in coldest position. If A/C compressor operates, problem is intermittent. If A/C compressor does not operate, go to next step.

2) Park vehicle inside or in shade. Open windows in order to ventilate interior of vehicle. If A/C system was operating, then allow A/C system to equalize for about 2 minutes. Turn ignition switch to OFF position. Install Refrigerant Station (J 43600 ACR 2000). Record outside air temperature at vehicle. Record readings of low and high side static pressures. Compare pressure values with specifications for ambient air temperature. See PRESSURE-TEMPERATURE RELATIONSHIP article in GENERAL SERVICING. If pressure values are within specification for ambient air temperature and within 15 psi (1.1 kg/cm²) of each other,

go to next step. If pressure values are not within specification for ambient air temperature or within 15 psi (1.1 kg/cm²) of each other, see LEAK TESTING article in GENERAL SERVICING.

3) If HVAC control assembly is inoperative, go to step 5). If HVAC control assembly is not inoperative, go to next step.

4) Start engine. Using scan tool, observe A/C REQUEST SIGNAL parameter in ENGINE DATA 2 data list. Place A/C request switch in ON position. If scan tool indicates A/C REQUEST SIGNAL parameter is YES, go to step 7). If scan tool does not indicate A/C REQUEST SIGNAL parameter is YES, go to step 8).

5) Check voltage supply circuit (Brown wire) to HVAC control assembly for short to ground, high resistance, or open. If problem was found, repair as necessary. After repairs, go to step 38). If problem was not found, go to next step.

6) Check ground circuit (Black wire) to HVAC control assembly for high resistance or open. If problem was found, repair as necessary. After repairs, go to step 38). If problem was not found, go to step 29).

7) If scan tool indicates A/C COMPRESSOR CYCLING SWITCH parameter is CLOSED, go to step 14). If scan tool does not indicate A/C COMPRESSOR CYCLING SWITCH parameter is CLOSED, go to step 9).

8) Turn ignition switch to OFF position. Disconnect A/C high pressure switch. Connect fused jumper (3 amp) between A/C high pressure switch connector terminals. Start engine. Using scan tool, observe A/C REQUEST parameter. Place A/C request switch in ON position. If scan tool indicates A/C REQUEST parameter is YES, go to step 30). If scan tool does not indicate A/C REQUEST parameter is YES, go to step 10).

9) Turn ignition switch to OFF position. Disconnect A/C low pressure cutout switch. Connect fused jumper (3 amp) between A/C low pressure cutout switch signal connector terminals. Start engine. Using scan tool, observe A/C COMPRESSOR CYCLING SWITCH parameter. If scan tool indicates A/C COMPRESSOR CYCLING SWITCH parameter is CLOSED, go to step 27). If scan tool does not indicate A/C COMPRESSOR CYCLING SWITCH parameter is CLOSED, go to step 12).

10) Turn ignition switch to OFF position. Reconnect A/C high pressure switch. Check A/C request signal circuit (Light Green wire and Dark Green/White wire) for short to ground, high resistance or open. If problem was found, repair as necessary. After repairs, go to step 38). If problem was not found, go to next step.

11) Measure voltage between A/C request signal circuit (Dark Green/White wire) at PCM an ground. If battery voltage is present, go to step 31). If battery voltage is not present, go to step 29).

12) Check A/C low pressure switch signal circuit (Dark Green wire) for high resistance or open. If problem was found, repair as necessary. After repairs, go to step 38). If problem was not found, go to next step.

13) Check ground circuit (Black wire) of A/C low pressure switch for high resistance or open. If problem was found, repair as necessary. After repairs, go to step 38). If problem was not found, go to step 31).

14) Using scan tool, command A/C compressor clutch relay on and off. If A/C compressor clutch relay turns on and off with each command, go to next step. If A/C compressor clutch relay does not turn on and off with each command, go to step 17).

15) Turn ignition switch to OFF position. Disconnect A/C compressor clutch relay. Using test light connected to ground, probe switch side voltage supply circuit (Orange wire) of A/C compressor clutch relay. If test light is on, go to next step. If test light is off, go to step 25).

16) Connect fused jumper (10 amp) between switch side voltage circuit (Orange wire) of A/C compressor clutch relay and A/C compressor clutch supply voltage circuit (Dark Green wire) of A/C

compressor clutch. Turn ignition switch to ON position, with engine off. If A/C compressor clutch engages, go to step 27). If A/C compressor clutch does not engage, go to step 20).

17) Turn ignition switch to OFF position. Disconnect A/C compressor clutch relay. Turn ignition switch to ON position, with engine off. Using test light connected to ground, probe coil side voltage supply circuit (Pink wire) of A/C compressor clutch relay. If test light is on, go to next step. If test light is off, go to step 24).

18) Connect test light between control circuit (Dark Green/White wire) of A/C compressor clutch relay and coil side voltage supply circuit (Pink wire) of A/C compressor clutch relay. Using scan tool, command A/C compressor clutch relay on and off. If test light turns on and off with each command, go to step 26). If test light does not turn on and off with each command, go to next step.

19) If test light remains on with each command, go to step 22). If test light does not remain on with each command, go to step 23).

20) Check A/C compressor clutch supply voltage circuit (Dark Green wire) at A/C compressor clutch for short to ground, high resistance or open. If problem was found, repair as necessary. After repairs, go to step 38). If problem was not found, go to next step.

21) Check ground circuit (Black wire) of A/C compressor clutch for high resistance or open. If problem was found, repair as necessary. After repairs, go to step 38). If problem was not found, go to step 28).

22) Check control circuit (Dark Green/White wire) of A/C compressor clutch relay for short to ground. If problem was found, repair as necessary. After repairs, go to step 38). If problem was not found, go to step 31).

23) Check control circuit (Dark Green/White wire) of A/C compressor clutch relay for open. If problem was found, repair as necessary. After repairs, go to step 38). If problem was not found, go to step 31).

24) Repair coil side voltage supply circuit (Pink wire) of A/C compressor clutch relay. After repairs, go to step 38).

25) Repair switch side voltage supply circuit (Orange wire) of A/C compressor clutch relay. After repairs, go to step 38).

26) Check A/C compressor clutch relay connector for poor connections. If problem was found, repair as necessary. After repairs, go to step 38). If problem was not found, go to step 32).

27) Check A/C low pressure switch connector for poor connections. If problem was found, repair as necessary. After repairs, go to step 38). If problem was not found, go to step 33).

28) Check A/C compressor clutch connector for poor connections. If problem was found, repair as necessary. After repairs, go to step 38). If problem was not found, go to step 35).

29) Check HVAC control assembly connector for poor connections. If problem was found, repair as necessary. After repairs, go to step 38). If problem was not found, go to step 36).

30) Check A/C high pressure switch connector for poor connections. If problem was found, repair as necessary. After repairs, go to step 38). If problem was not found, go to step 34).

31) Check PCM connectors for poor connections. If problem was found, repair as necessary. After repairs, go to step 38). If problem was not found, go to step 37).

32) Replace A/C compressor clutch relay. After repairs, go to step 38).

33) Replace A/C low pressure switch. After repairs, go to step 38).

34) Replace A/C high pressure switch. After repairs, go to step 38).

35) Replace A/C compressor clutch coil. See appropriate

COMPRESSOR SERVICING article in GENERAL SERVICING. After repairs, go to step 38).

36) Replace HVAC control assembly. See REMOVAL & INSTALLATION in appropriate MANUAL A/C-HEATER SYSTEMS article. After repairs, go to step 38).

37) Replace PCM. See appropriate REMOVAL, OVERHAUL & INSTALLATION article in ENGINE PERFORMANCE. After repairs, go to next step.

38) Operate system to verify repair.

Compressor Clutch Does Not Engage (With 6.5L)

1) Ensure ambient air temperature is greater than 3°C (38°F). Start engine. Turn blower motor switch to maximum speed position. Place A/C request switch in ON position. Place air temperature control switch in coldest position. If A/C compressor operates, problem is intermittent. If A/C compressor does not operate, go to next step.

2) Park vehicle inside or in shade. Open windows in order to ventilate interior of vehicle. If A/C system was operating, then allow A/C system to equalize for about 2 minutes. Turn ignition switch to OFF position. Install Refrigerant Station (J 43600 ACR 2000). Record outside air temperature at vehicle. Record readings of low and high side static pressures. Compare pressure values with specifications for ambient air temperature. See PRESSURE-TEMPERATURE RELATIONSHIP article in GENERAL SERVICING. If pressure values are within specification for ambient air temperature and within 15 psi (1.1 kg/cm²) of each other, go to next step. If pressure values are not within specification for ambient air temperature or within 15 psi (1.1 kg/cm²) of each other, see LEAK TESTING article in GENERAL SERVICING.

3) If HVAC control assembly is inoperative, go to step 5). If HVAC control assembly is not inoperative, go to next step.

4) Start engine. Using scan tool, observe A/C REQUEST parameter in ENGINE DATA 1 data list. Place A/C request switch in ON position. If scan tool indicates A/C REQUEST parameter is ON, go to step 11). If scan tool does not indicate A/C REQUEST parameter is ON, go to step 7).

5) Check voltage supply circuit (Brown wire) to HVAC control assembly for short to ground, high resistance or open. If problem was found, repair as necessary. After repairs, go to step 35). If problem was not found, go to next step.

6) Check ground circuit (Black wire) to HVAC control assembly for high resistance or open. If problem was found, repair as necessary. After repairs, go to step 35). If problem was not found, go to step 26).

7) Turn ignition switch to OFF position. Disconnect A/C high pressure switch. Connect fused jumper (3 amp) between A/C high pressure switch connector terminals. Start engine. Using scan tool, observe A/C REQUEST parameter. Place A/C request switch in ON position. If scan tool indicates A/C REQUEST parameter is ON, go to step 27). If scan tool does not indicate A/C REQUEST parameter is ON, go to next step.

8) Turn ignition switch to OFF position. Disconnect A/C low pressure switch. Connect fused jumper (3 amp) between A/C low pressure switch connector terminals. Start engine. Using scan tool, observe A/C REQUEST parameter. Place A/C request switch in ON position. If scan tool indicates A/C REQUEST parameter is ON, go to step 24). If scan tool does not indicate A/C REQUEST parameter is ON, go to next step.

9) Turn ignition switch to OFF position. Reconnect A/C high pressure switch. Reconnect A/C low pressure switch. Check A/C request signal circuit (Light Green wire, Dark Green wire and Dark Green/White wire) for short to ground, high resistance or open. If problem was found, repair as necessary. After repairs, go to step 35). If problem was not found, go to next step.

10) Measure voltage between A/C request signal circuit (Dark

Green/White wire) at PCM and ground. If battery voltage is present, go to step 28). If battery voltage is not present, go to step 26).

11) Using scan tool, command A/C compressor clutch relay on and off. If A/C compressor clutch relay turns on and off with each command, go to next step. If A/C compressor clutch relay does not turn on and off with each command, go to step 14).

12) Turn ignition switch to OFF position. Disconnect A/C compressor clutch relay. Using test light connected to ground, probe switch side voltage supply circuit (Orange wire) of A/C compressor clutch relay. If test light is on, go to next step. If test light is off, go to step 22).

13) Connect fused jumper (10 amp) between switch side voltage circuit (Orange wire) of A/C compressor clutch relay and A/C compressor clutch supply voltage circuit (Dark Green wire) of A/C compressor clutch. Turn ignition switch to ON position, with engine off. If A/C compressor clutch engages, go to step 23). If A/C compressor clutch does not engage, go to step 17).

14) Turn ignition to OFF position. Disconnect A/C compressor clutch relay. Turn ignition switch to ON position, with engine off. Using test light connected to ground, probe coil side voltage supply circuit of A/C compressor clutch relay. If test light is on, go to next step. If test light is off, go to step 21).

15) Connect test light between control circuit (Dark Green/White wire) of A/C compressor clutch relay and coil side voltage supply circuit (Pink wire) of A/C compressor clutch relay. Using scan tool, command A/C compressor clutch relay on and off. If test light turns on and off with each command, go to step 23). If test light does not turn on and off with each command, go to next step.

16) If test light remains on with each command, go to step 19). If test light does not remain on with each command, go to step 20).

17) Check A/C compressor clutch supply voltage circuit (Dark Green wire) at A/C compressor clutch for short to ground, high resistance or open. If problem was found, repair as necessary. After repairs, go to step 35). If problem was not found, go to next.

18) Check ground circuit (Black wire) of A/C compressor clutch for high resistance or open. If problem was found, repair as necessary. After repairs, go to step 35). If problem was not found, go to step 25).

19) Check control circuit (Dark Green/White wire) of the A/C compressor clutch relay for a short to ground. If problem was found, repair as necessary. After repairs, go to step 35). If problem was not found, go to step 28).

20) Check control circuit (Dark Green/White wire) of A/C compressor clutch relay for open. If problem was found, repair as necessary. After repairs, go to step 35). If problem was not found, go to step 28).

21) Repair coil side voltage supply circuit (Pink wire) of A/C compressor clutch relay. After repairs, go to step 35).

22) Repair switch side voltage supply circuit (Orange wire) of A/C compressor clutch relay. After repairs, go to step 35).

23) Check A/C compressor clutch relay connector for poor connections. If problem was found, repair as necessary. After repairs, go to step 35). If problem was not found, go to step 29).

24) Check A/C low pressure switch connector for poor connections. If problem was found, repair as necessary. After repairs, go to step 35). If problem was not found, go to step 30).

25) Check A/C compressor clutch connector for poor connections. If problem was found, repair as necessary. After repairs, go to step 35). If problem was not found, go to step 32).

26) Check HVAC control assembly connector for poor connections. If problem was found, repair as necessary. After repairs, go to step 35). If problem was not found, go to step 33).

27) Check A/C high pressure switch connector for poor connections. If problem was found, repair as necessary. After repairs, go to step 35). If problem was not found, go to step 31).

28) Check PCM connectors for poor connections. If problem was found, repair as necessary. After repairs, go to step 35). If problem was not found, go to step 34).

29) Replace A/C compressor clutch relay. After repairs, go to step 35).

30) Replace A/C low pressure switch. After repairs, go to step 35).

31) Replace A/C high pressure switch. After repairs, go to step 35).

32) Replace A/C compressor clutch coil. See appropriate COMPRESSOR SERVICING article in GENERAL SERVICING. After repairs, go to step 35).

33) Replace HVAC control assembly. See REMOVAL & INSTALLATION in appropriate MANUAL A/C-HEATER SYSTEMS article. After repairs, go to step 35).

34) Replace PCM. See appropriate REMOVAL, OVERHAUL & INSTALLATION article in ENGINE PERFORMANCE. After repairs, go to next step.

35) Operate system to verify repair.

Compressor Clutch Does Not Disengage

1) Start engine. Place blower motor switch in OFF position. Place A/C request switch in OFF position. If A/C compressor operates, go to next step. If A/C compressor does not operate, problem is intermittent.

2) Using scan tool, observe A/C REQUEST parameter in ENGINE DATA 2 data list. If scan tool indicates A/C REQUEST parameter is ON, go to next step. If scan tool does not indicate A/C REQUEST parameter is ON, go to step 5).

3) Check A/C request signal circuit (Dark Green/White wire) for short to voltage. If problem was found, repair as necessary. After repairs, go to step 16). If problem was not found, go to next step.

4) Turn ignition switch to OFF position. Disconnect A/C high pressure switch. Start engine. Using scan tool, observe A/C REQUEST parameter. If scan tool indicates A/C REQUEST parameter is ON, go to step 11). If scan tool does not indicate A/C REQUEST parameter is ON, go to step 10).

5) Remove A/C compressor clutch relay. If A/C compressor clutch turns off, go to next step. If A/C compressor clutch does not turn off, go to step 8).

6) Measure resistance between switch side A/C compressor clutch relay terminals. If resistance is infinite, go to next step. If resistance is not infinite, go to step 9).

7) Check A/C clutch relay control circuit (Dark Green/White wire) for short to ground. If problem was found, repair as necessary. After repairs, go to step 16). If problem was not found, go to step 11).

8) Check A/C compressor clutch supply voltage circuit (Dark Green wire) for short to voltage. If problem was found, repair as necessary. After repairs, go to step 16). If problem was not found, go to step 13).

9) Check A/C compressor clutch relay connector for poor connections. If problem was found, repair as necessary. After repairs, go to step 16). If problem was not found, go to step 12).

10) Check HVAC control assembly connector for poor connections. If problem was found, repair as necessary. After repairs, go to step 16). If problem was not found, go to step 14).

11) Check PCM connectors for poor connections. If problem was found, repair as necessary. After repairs, go to step 16). If problem was not found, go to step 15).

12) Replace A/C compressor clutch relay. After repairs, go to step 16).

13) Replace A/C compressor clutch. See appropriate COMPRESSOR SERVICING article in GENERAL SERVICING. After repairs, go to step 16).

14) Replace HVAC control assembly. See REMOVAL & INSTALLATION in appropriate MANUAL A/C-HEATER SYSTEMS article. After repairs, go to step 16).

15) Replace PCM. See appropriate REMOVAL, OVERHAUL & INSTALLATION article in ENGINE PERFORMANCE. After repairs, go to next step.

16) Operate system to verify repair.

WIRING DIAGRAMS

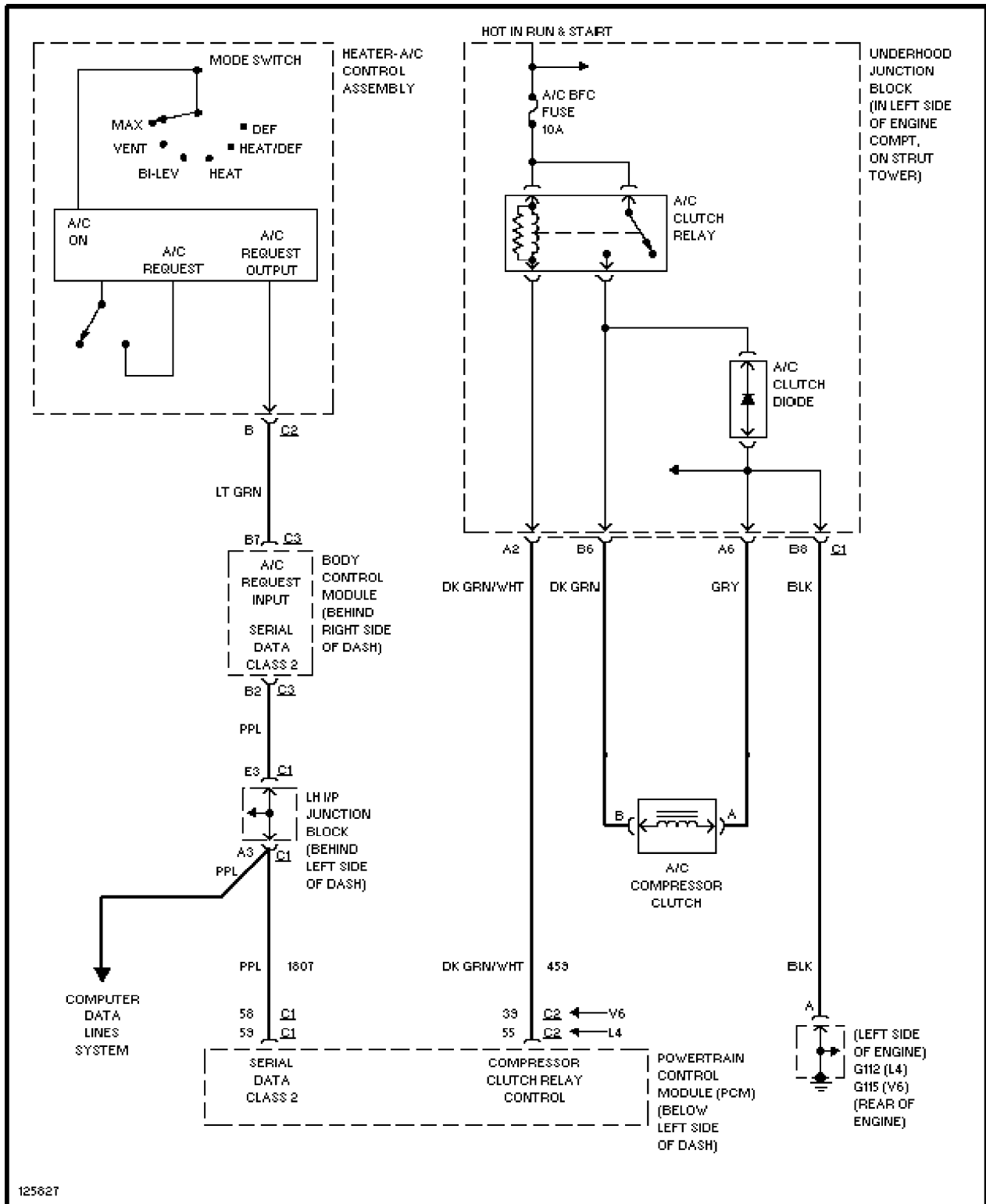

125827

Fig. 1: A/C Compressor Clutch Control Circuit Wiring Diagram (2000 Alero & Grand Am)

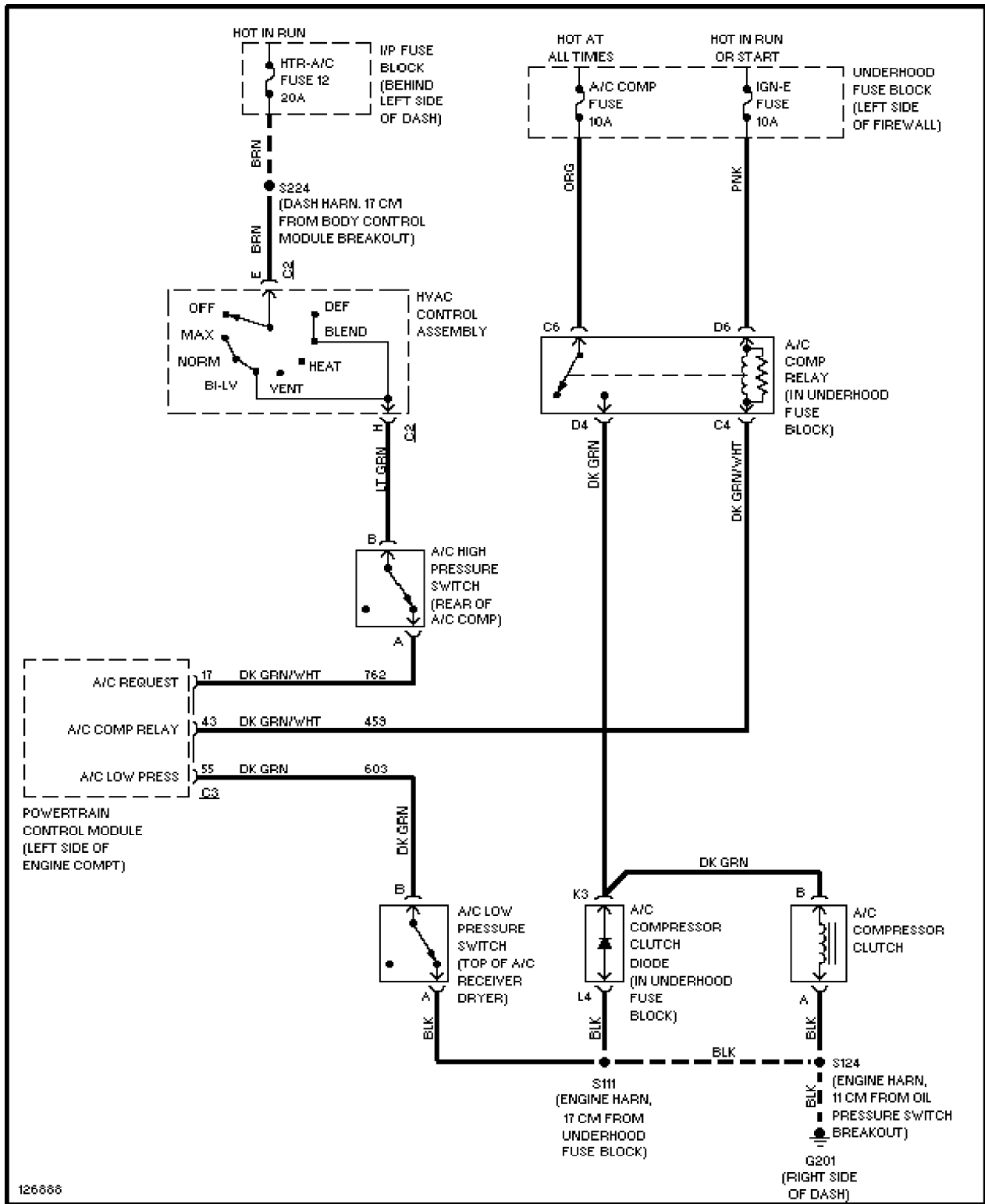

Fig. 2: A/C Compressor Clutch Control Circuit Wiring Diagram (2000-01 Astro & Safari)

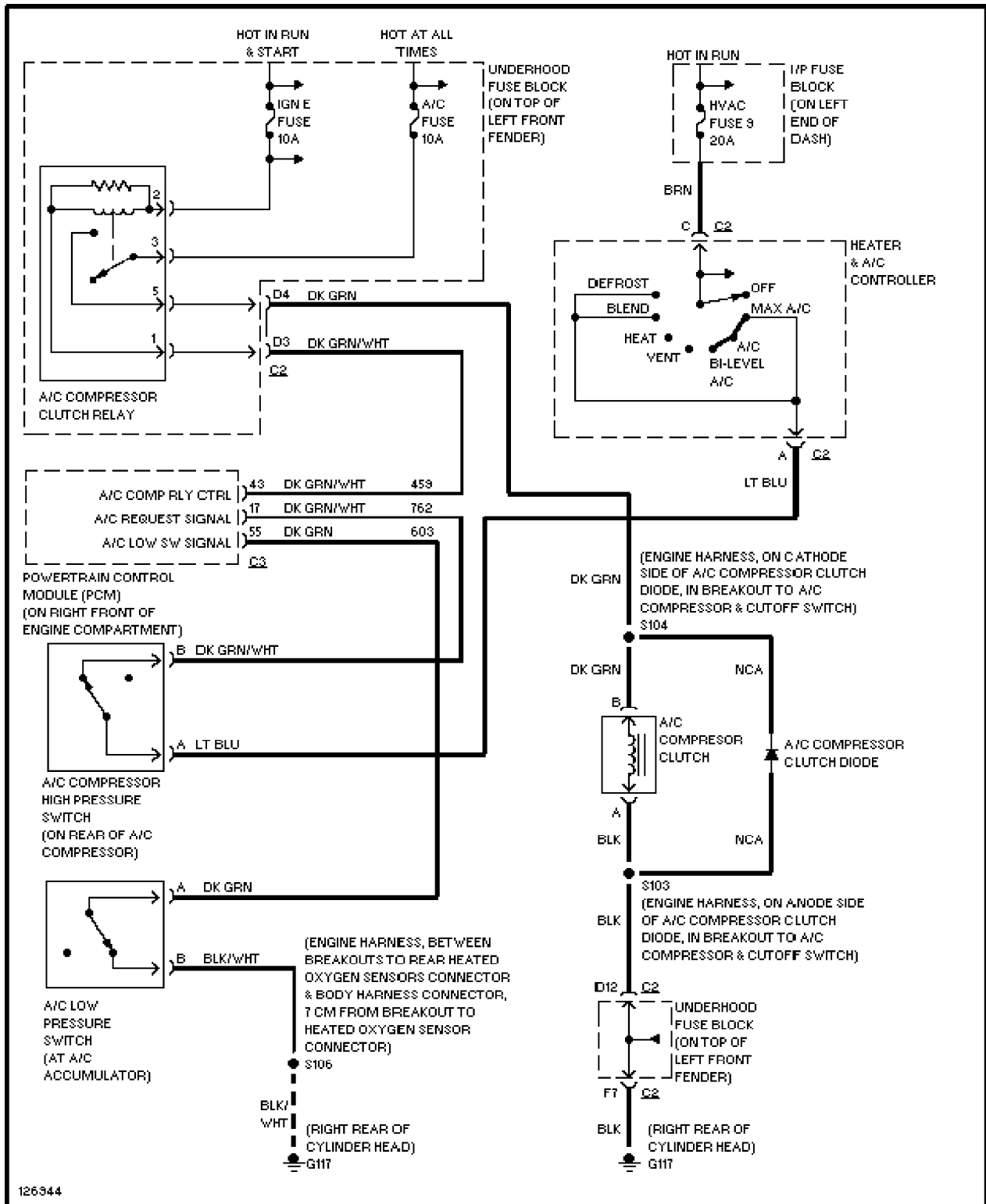

Fig. 3: A/C Compressor Clutch Control Circuit Wiring Diagram
 (2000-01 Blazer, Jimmy, Sonoma & S10 Pickup - With Manual A/C-Heater
 System & 4.3L VINs W & X Engine)

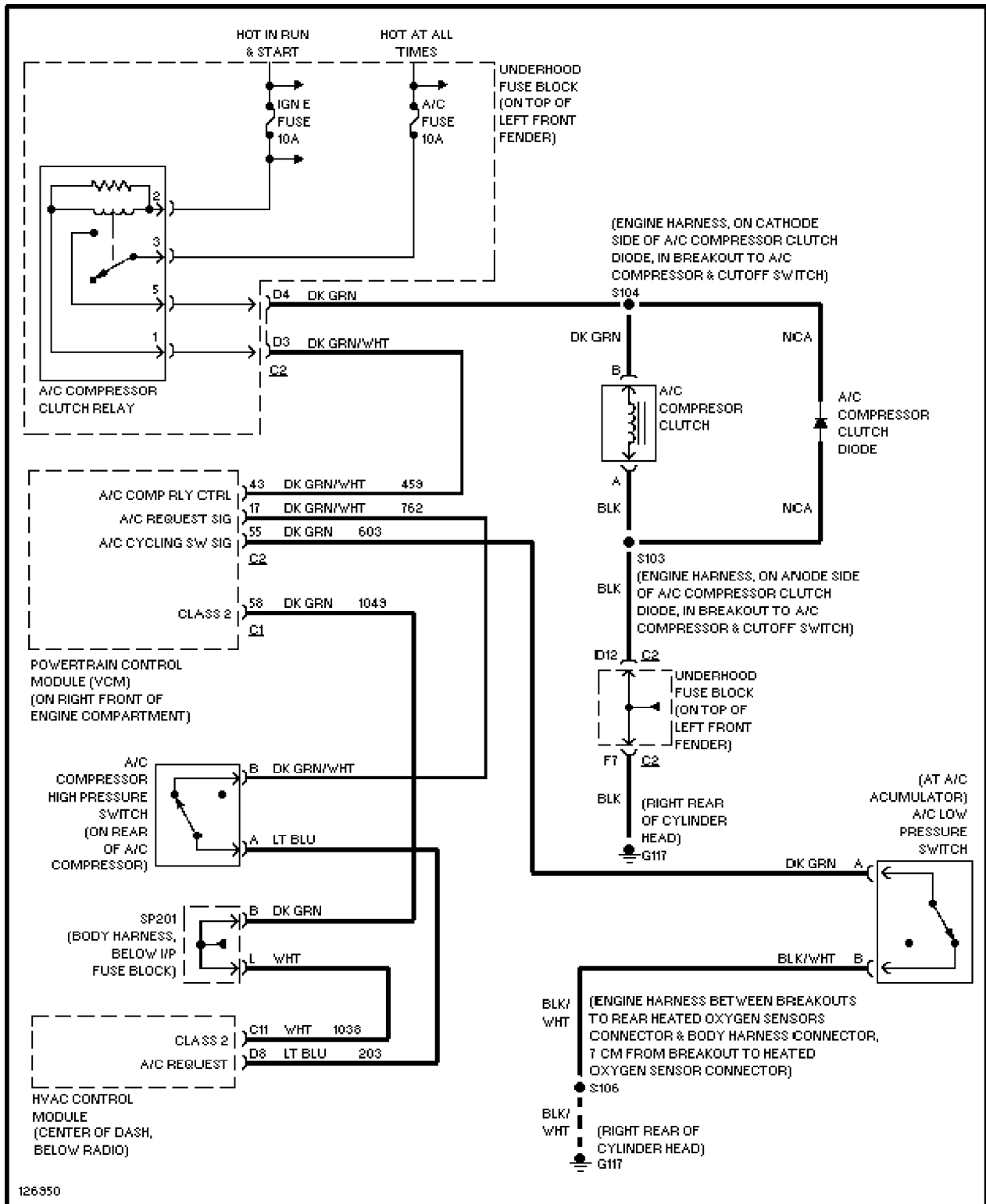

Fig. 4: A/C Compressor Clutch Control Circuit Wiring Diagram (2000-01 Blazer, Bravada, Envoy & Jimmy - With Automatic A/C-Heater System)

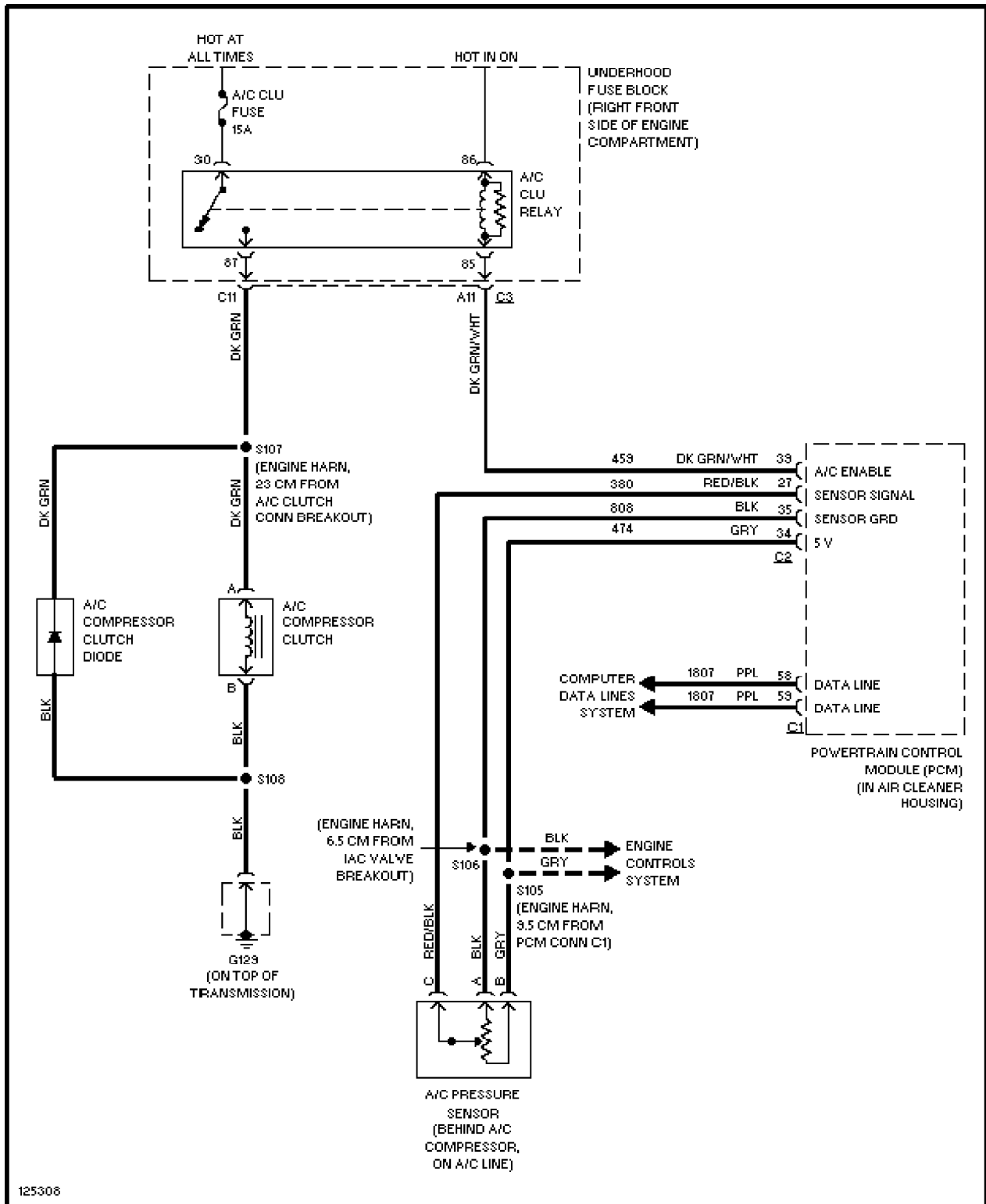

Fig. 5: A/C Compressor Clutch Control Circuit Wiring Diagram (2000-01 Bonneville & LeSabre)

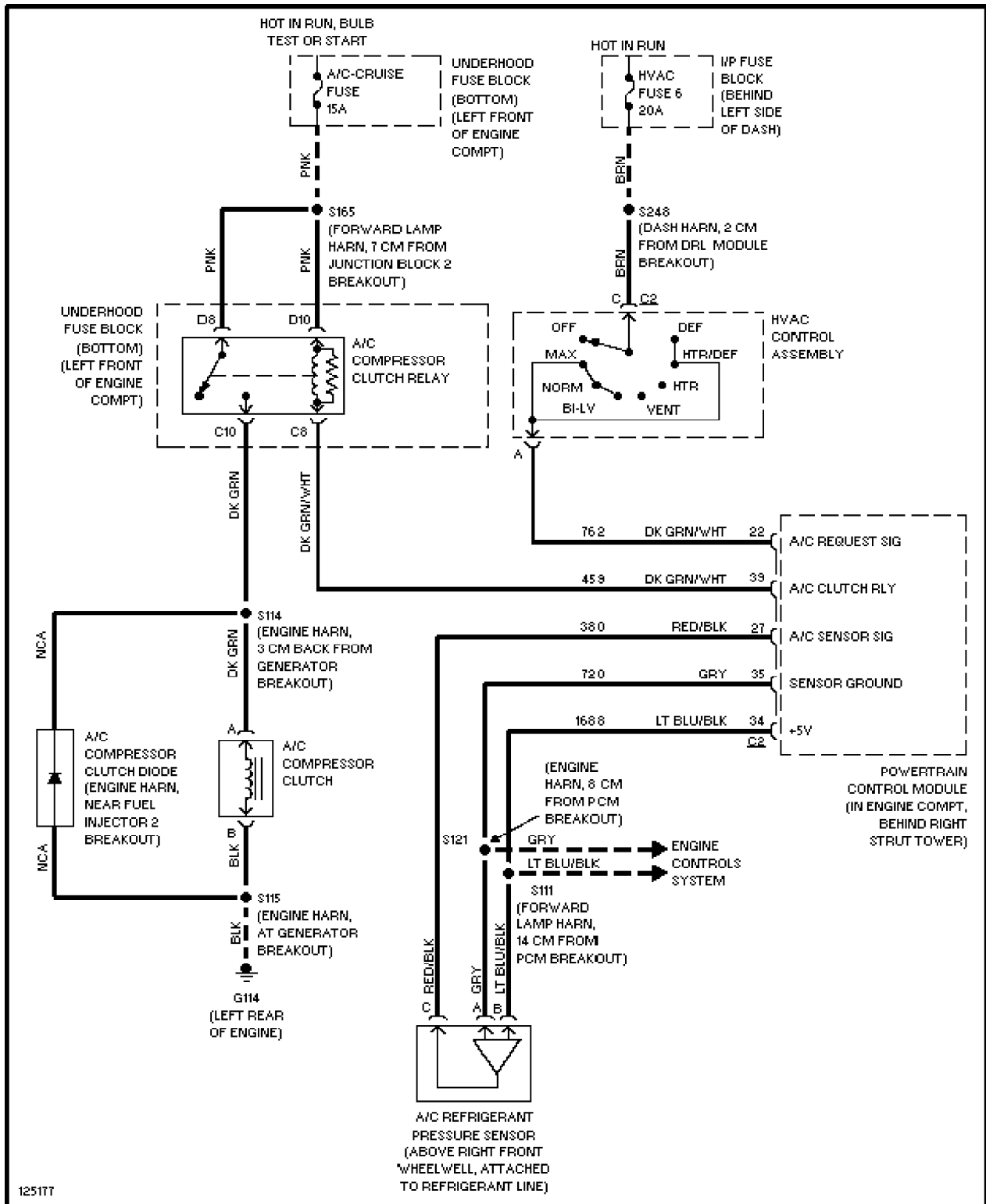

Fig. 6: A/C Compressor Clutch Control Circuit Wiring Diagram (2000-01 Camaro & Firebird - With 3.8L VIN K Engine)

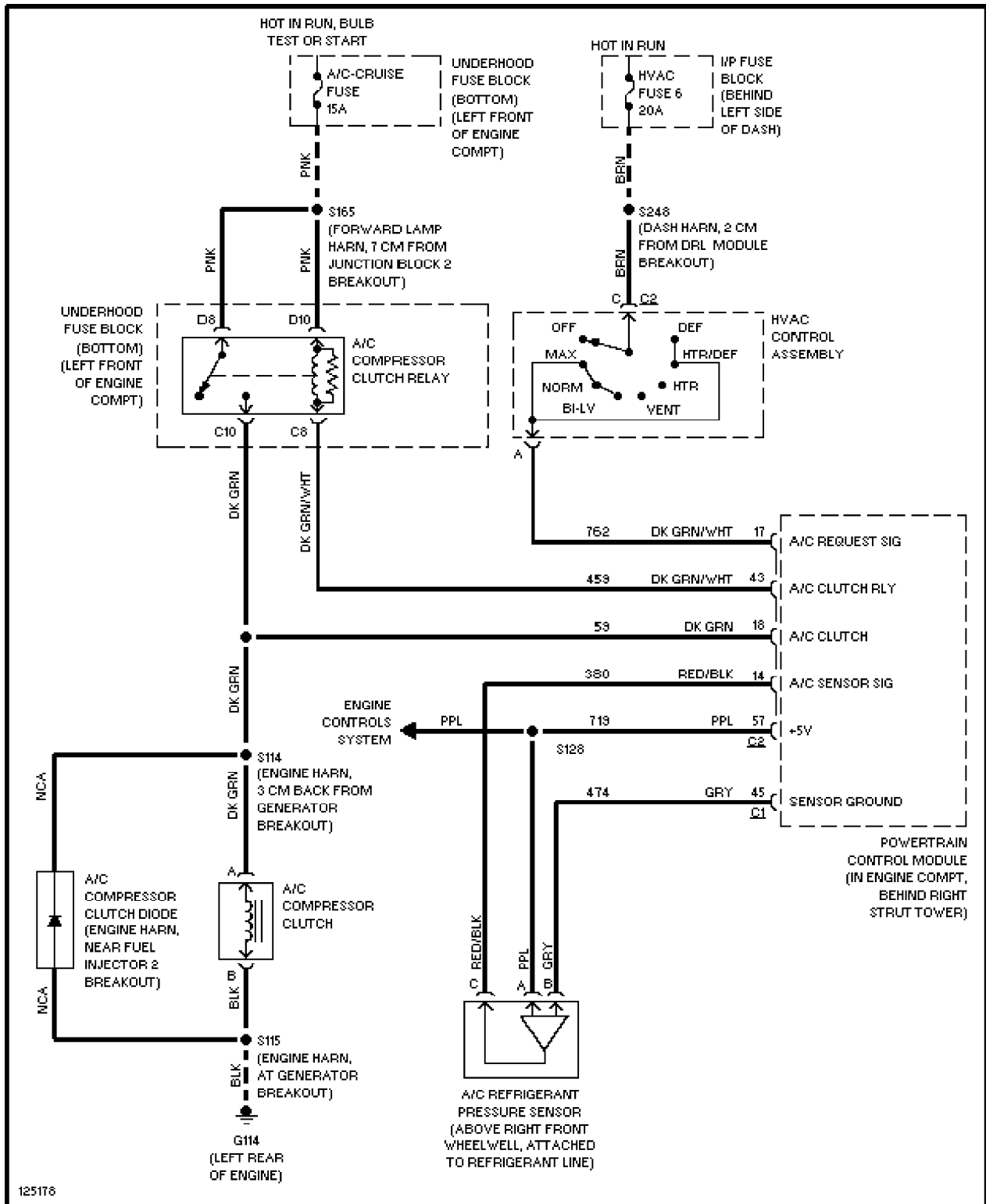

Fig. 7: A/C Compressor Clutch Control Circuit Wiring Diagram (2000-01 Camaro & Firebird - With 5.7L VIN G Engine)

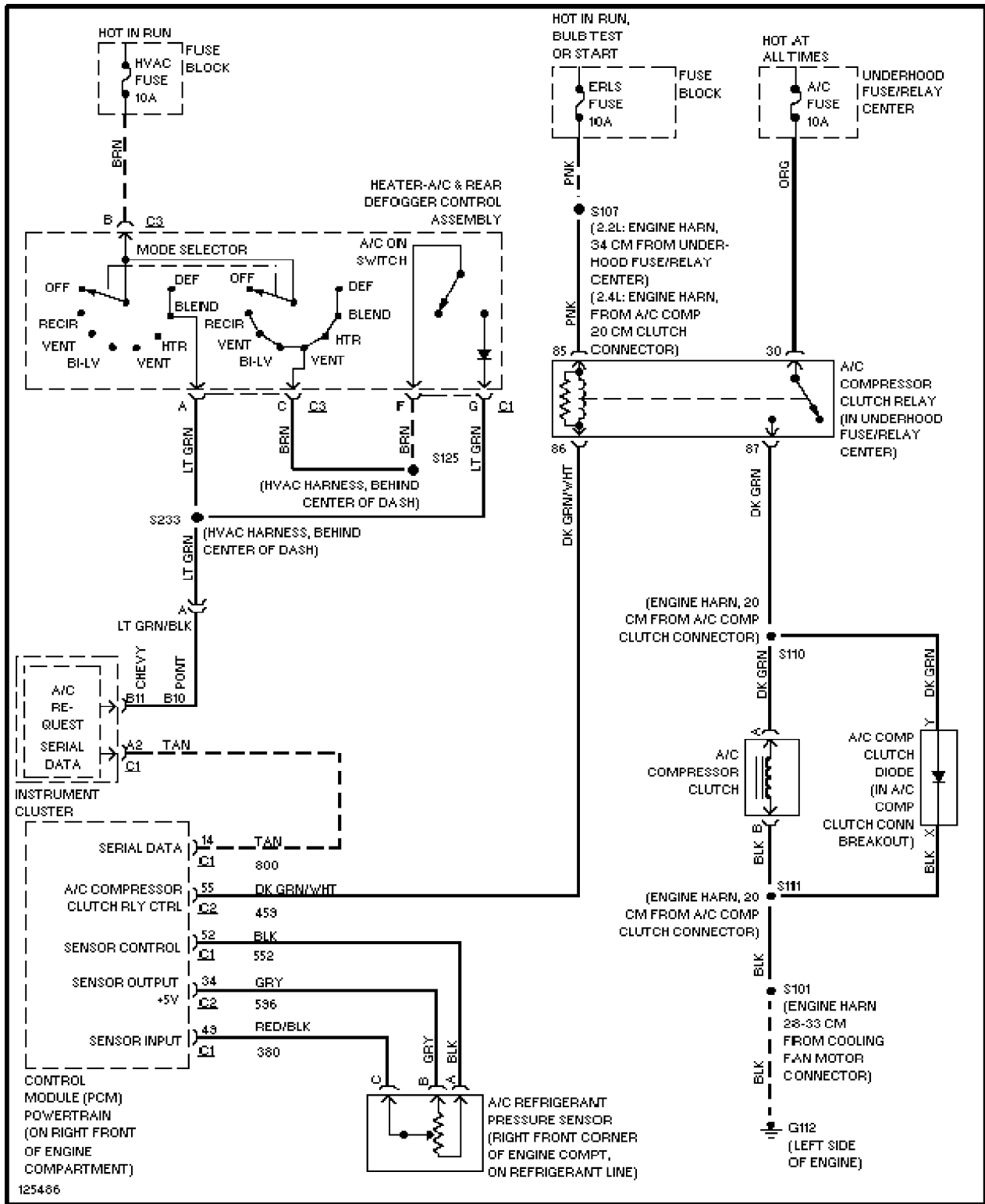

Fig. 9: A/C Compressor Clutch Control Circuit Wiring Diagram (2000 Cavalier & Sunfire)

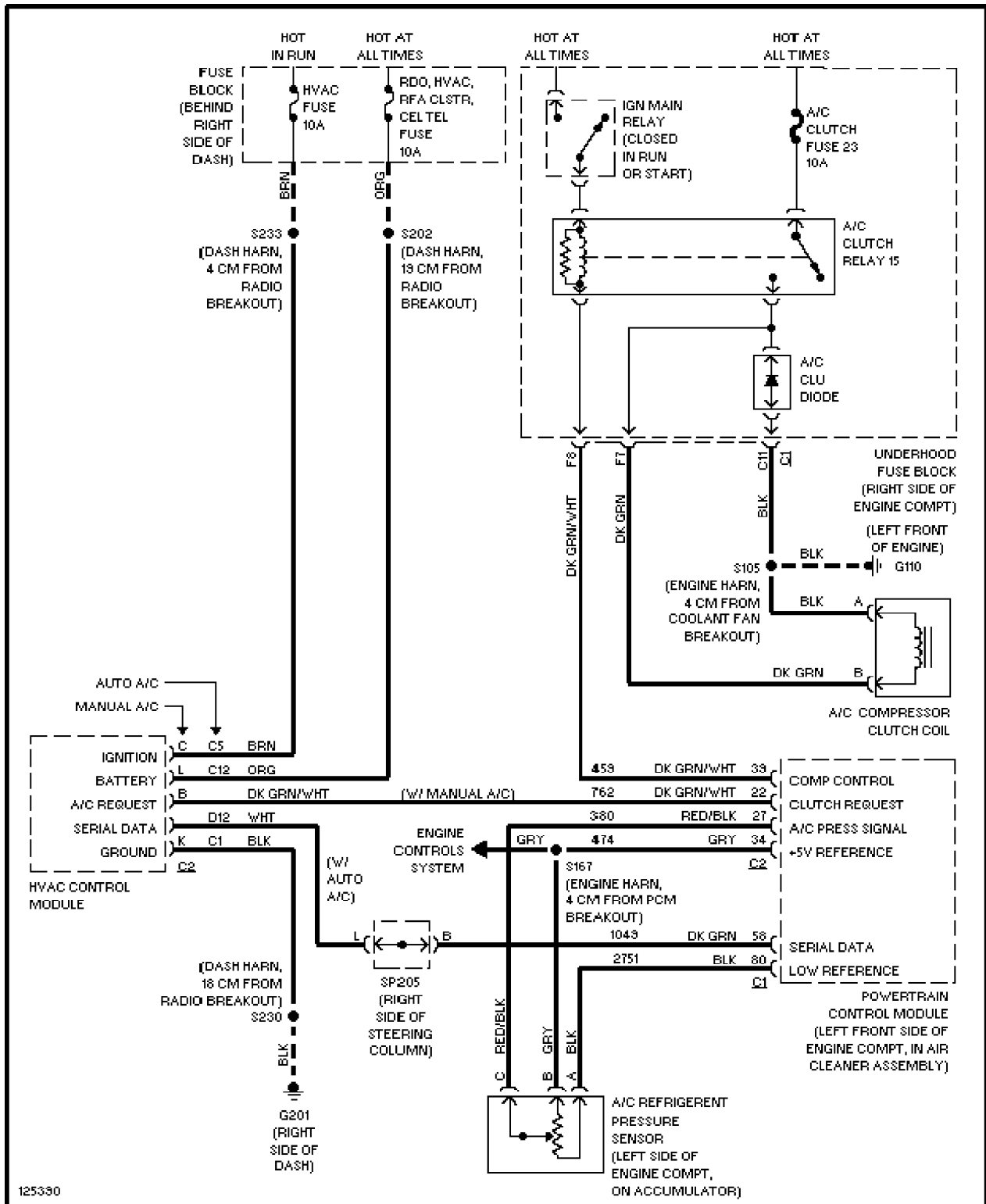

Fig. 10: A/C Compressor Clutch Control Circuit Wiring Diagram (2000-01 Century & Regal)

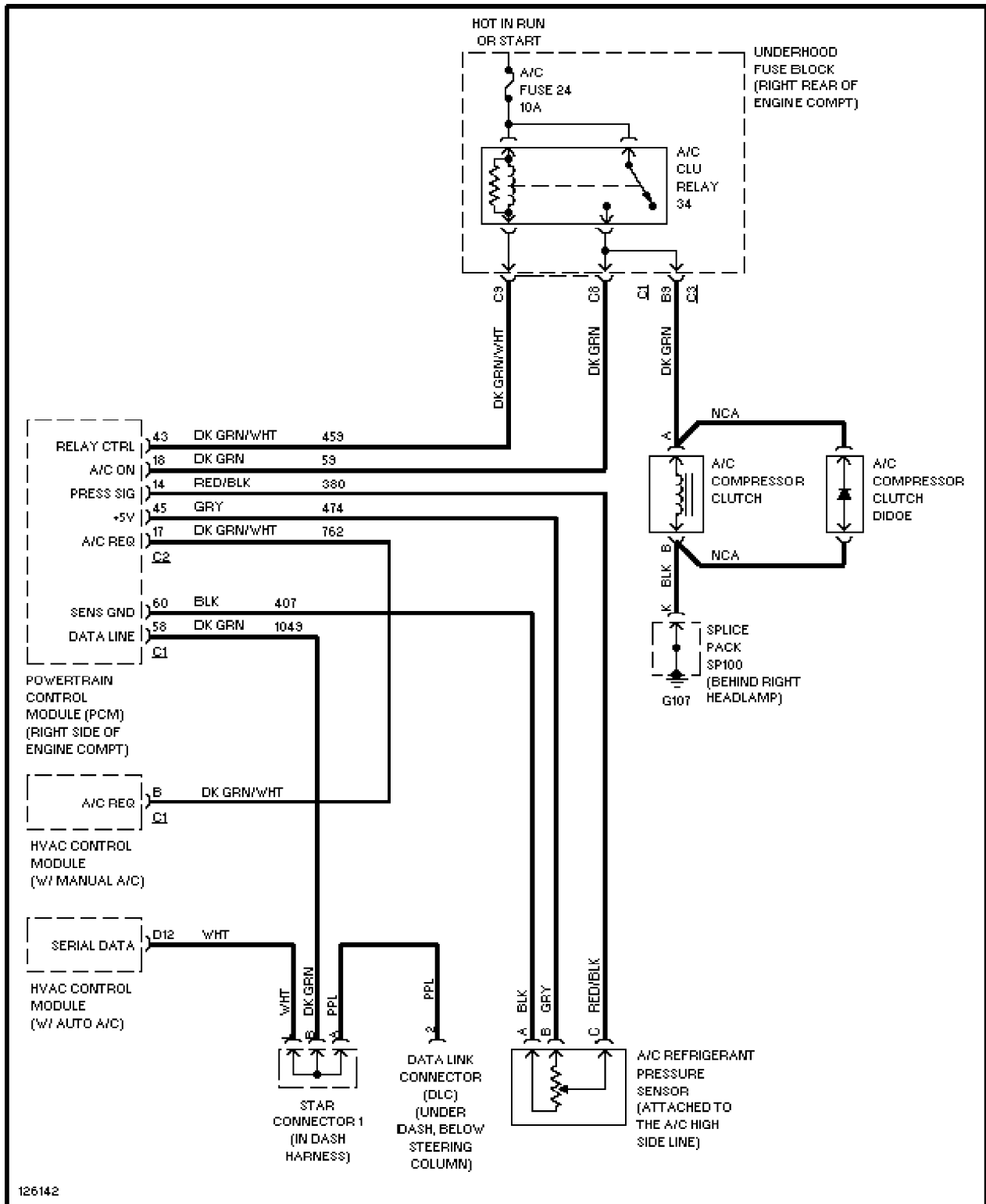

Fig. 11: A/C Compressor Clutch Control Circuit Wiring Diagram (2000-01 Corvette)

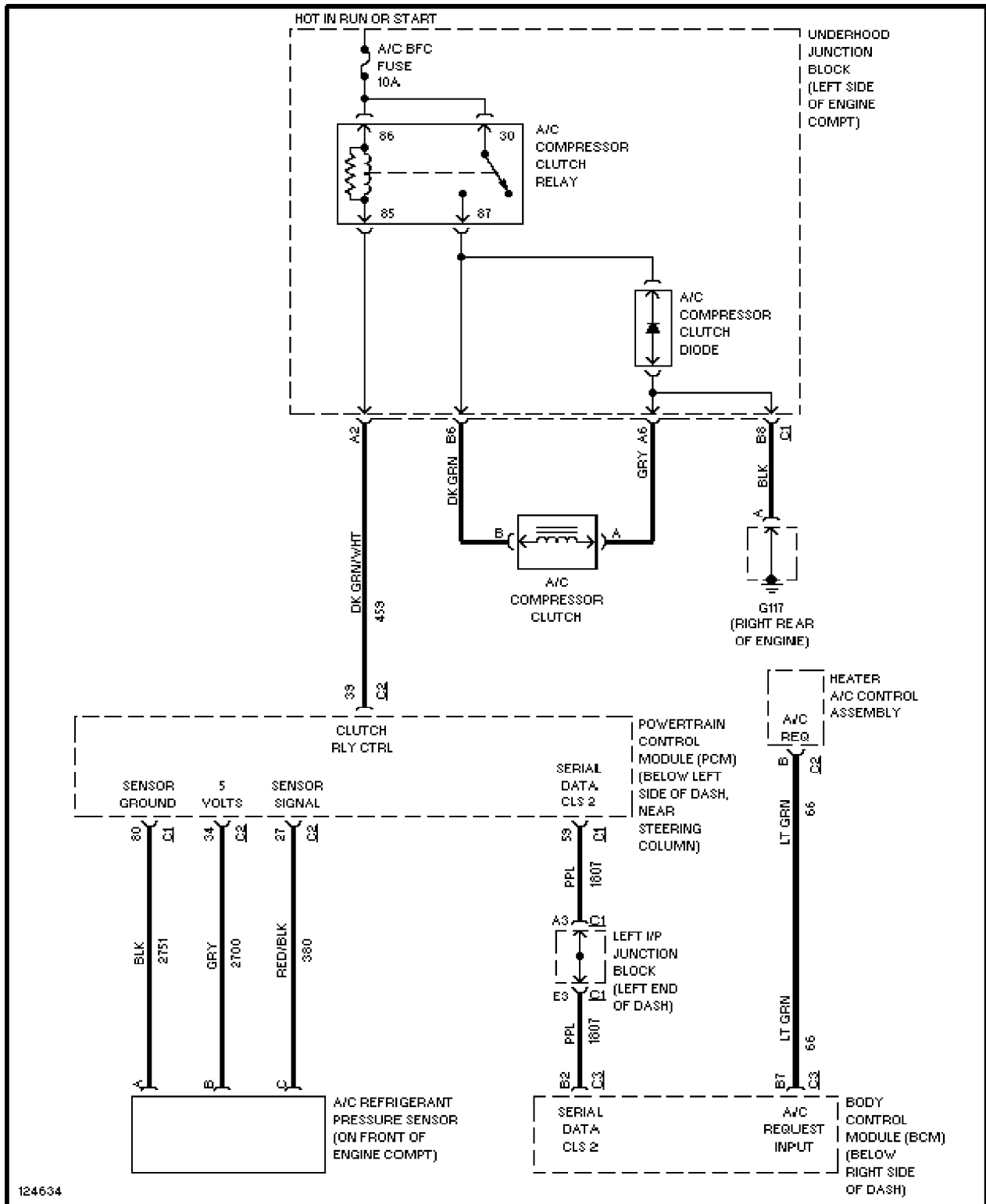

Fig. 12: A/C Compressor Clutch Control Circuit Wiring Diagram (2000-01 Malibu)

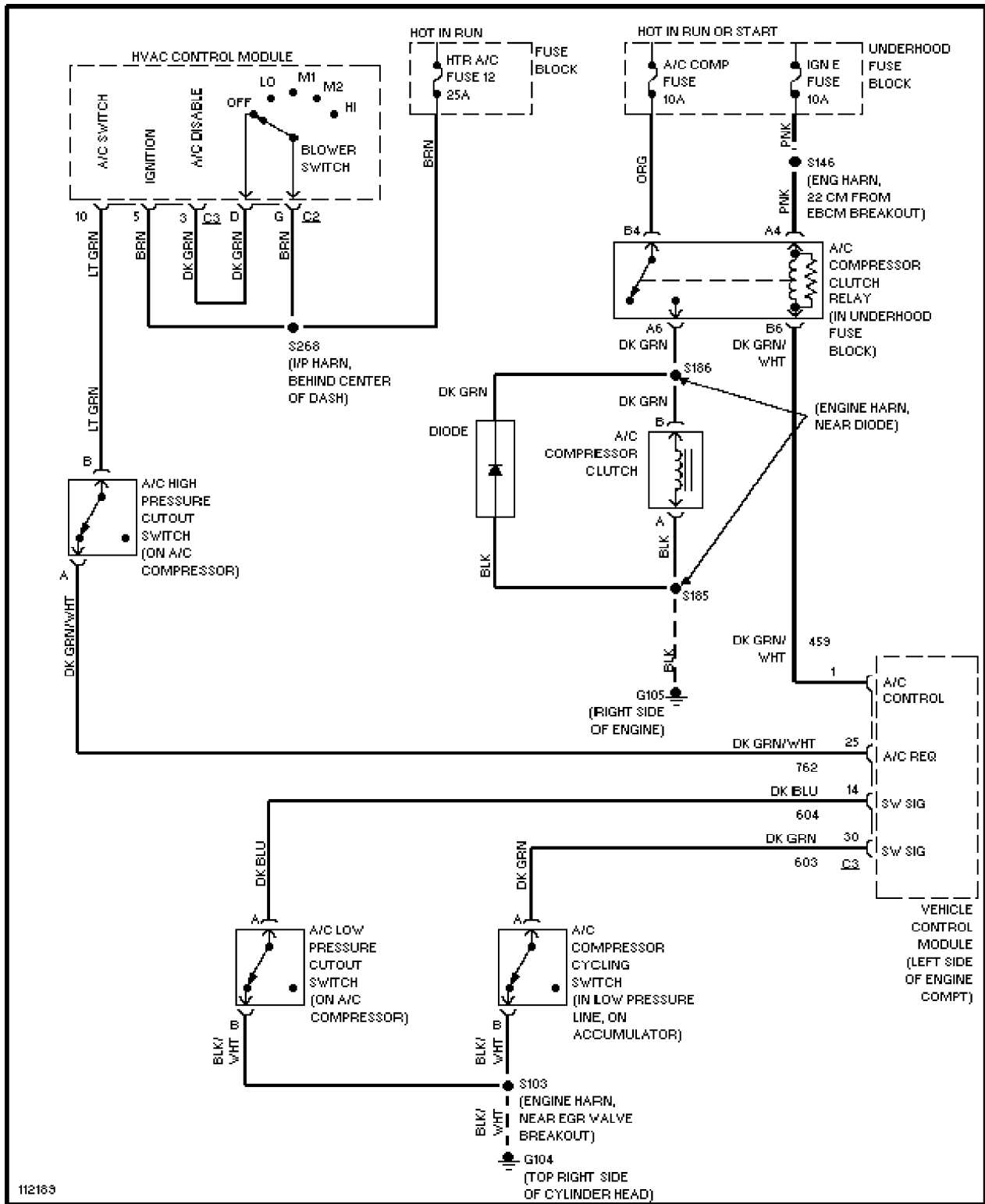

Fig. 13: A/C Compressor Clutch Control Circuit Wiring Diagram
 (2000 "C" & "K" Pickup, Escalade, Tahoe & Yukon - 5.7L VIN R & 7.4 VIN J)

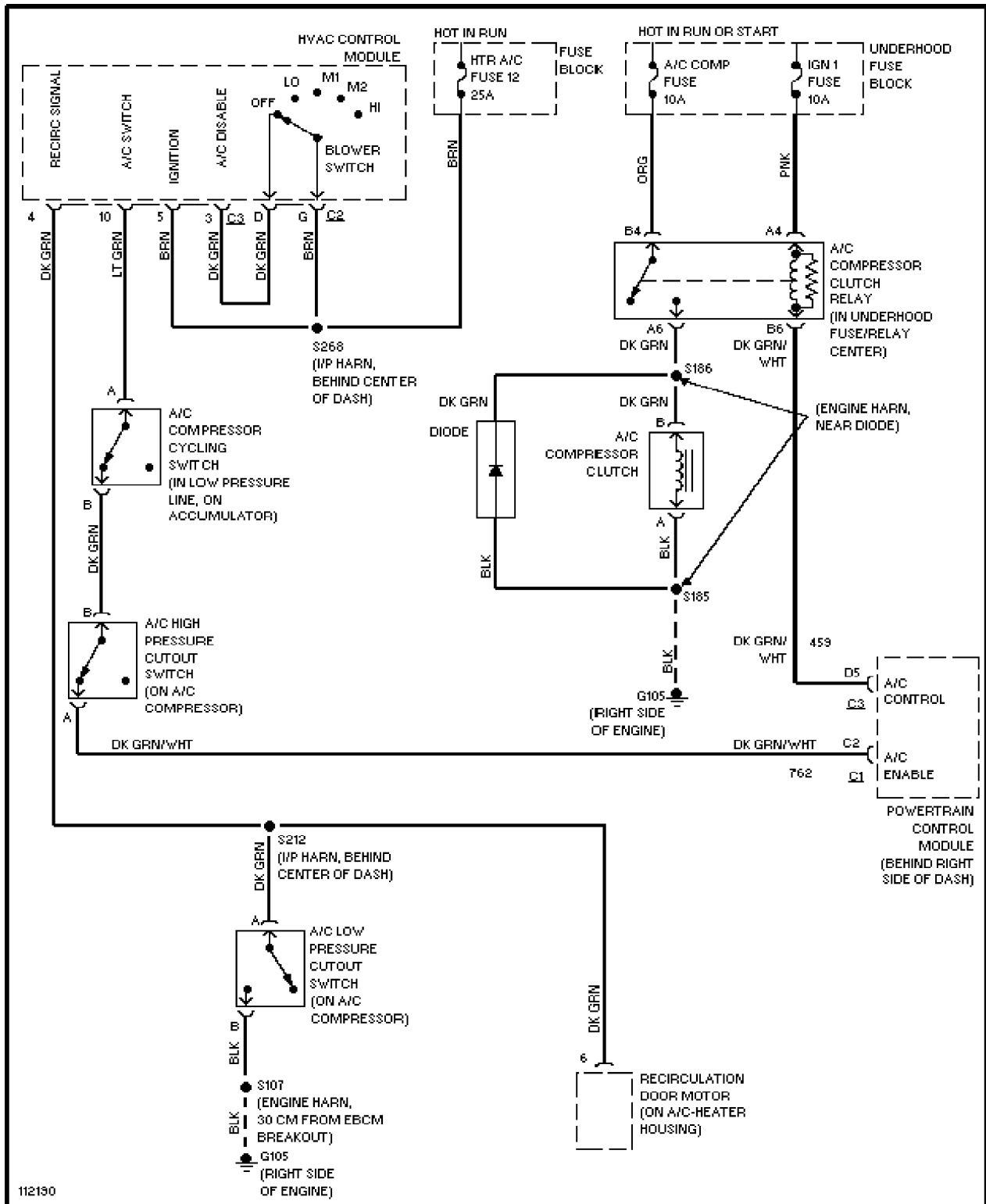
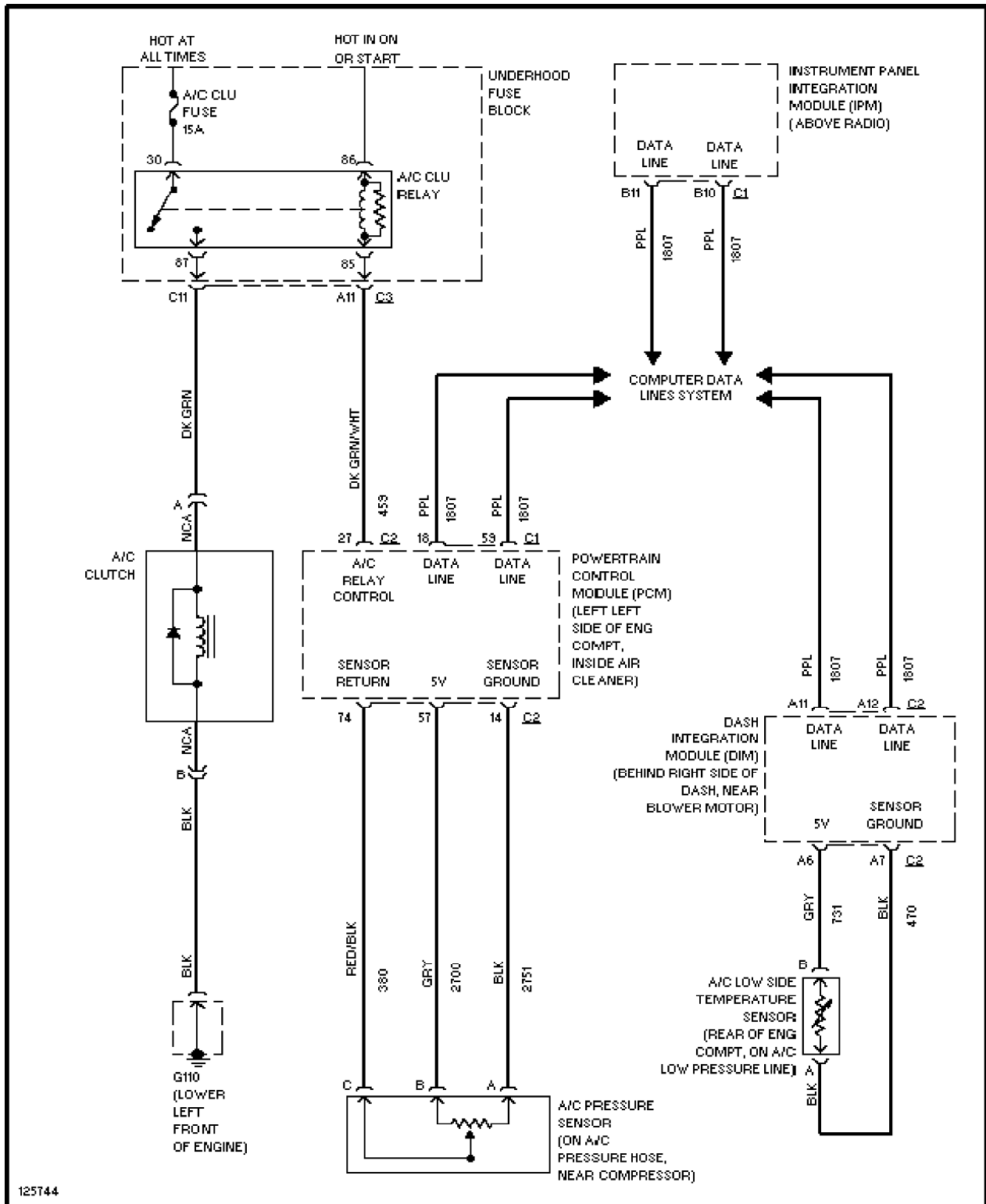

Fig. 14: A/C Compressor Clutch Control Circuit Wiring Diagram (2000 "C" & "K" Pickup - Diesel Engine)



125744

Fig. 15: A/C Compressor Clutch Control Circuit Wiring Diagram (2000 DeVille)

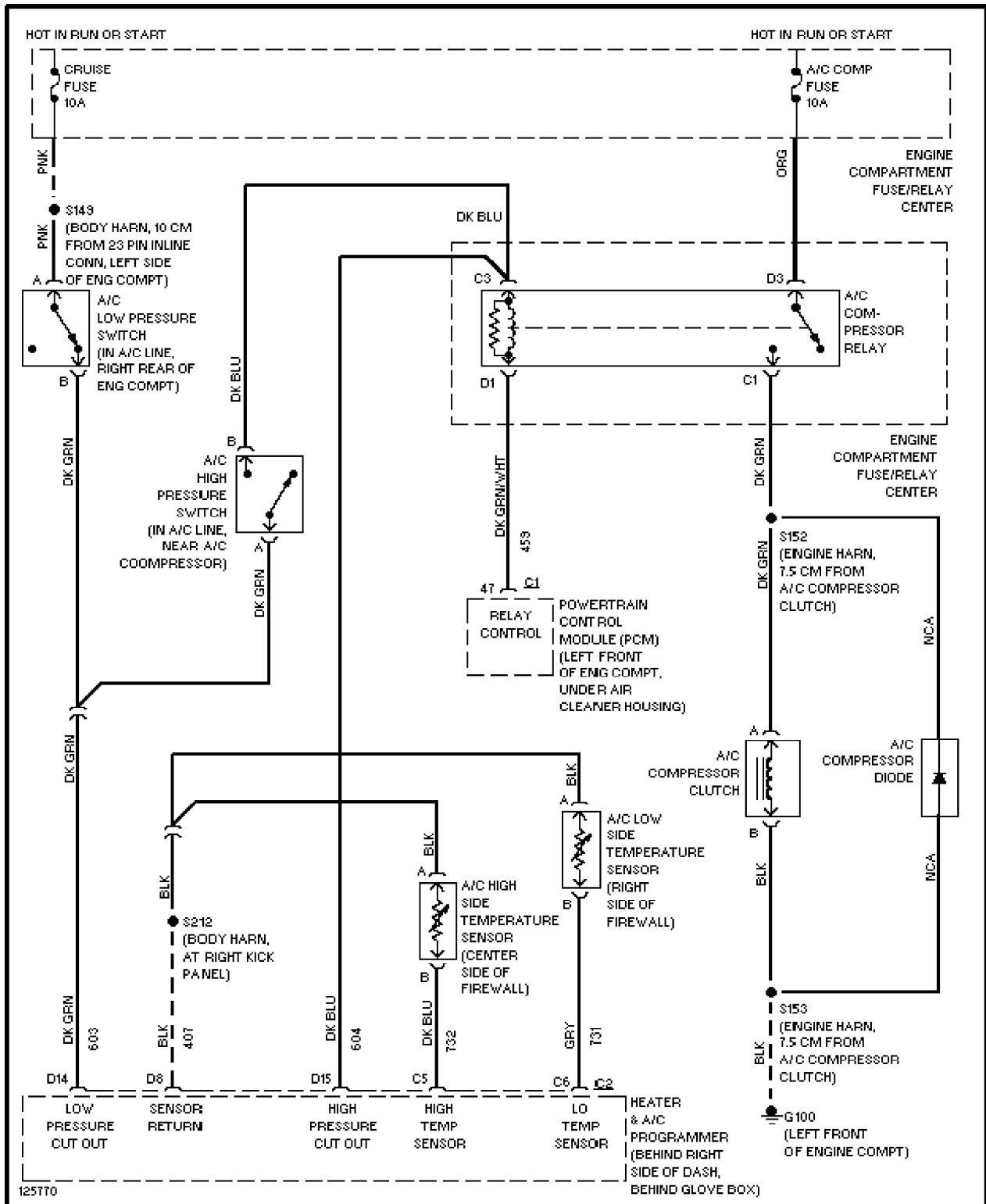

Fig. 16: A/C Compressor Clutch Control Circuit Wiring Diagram (2000 Eldorado)

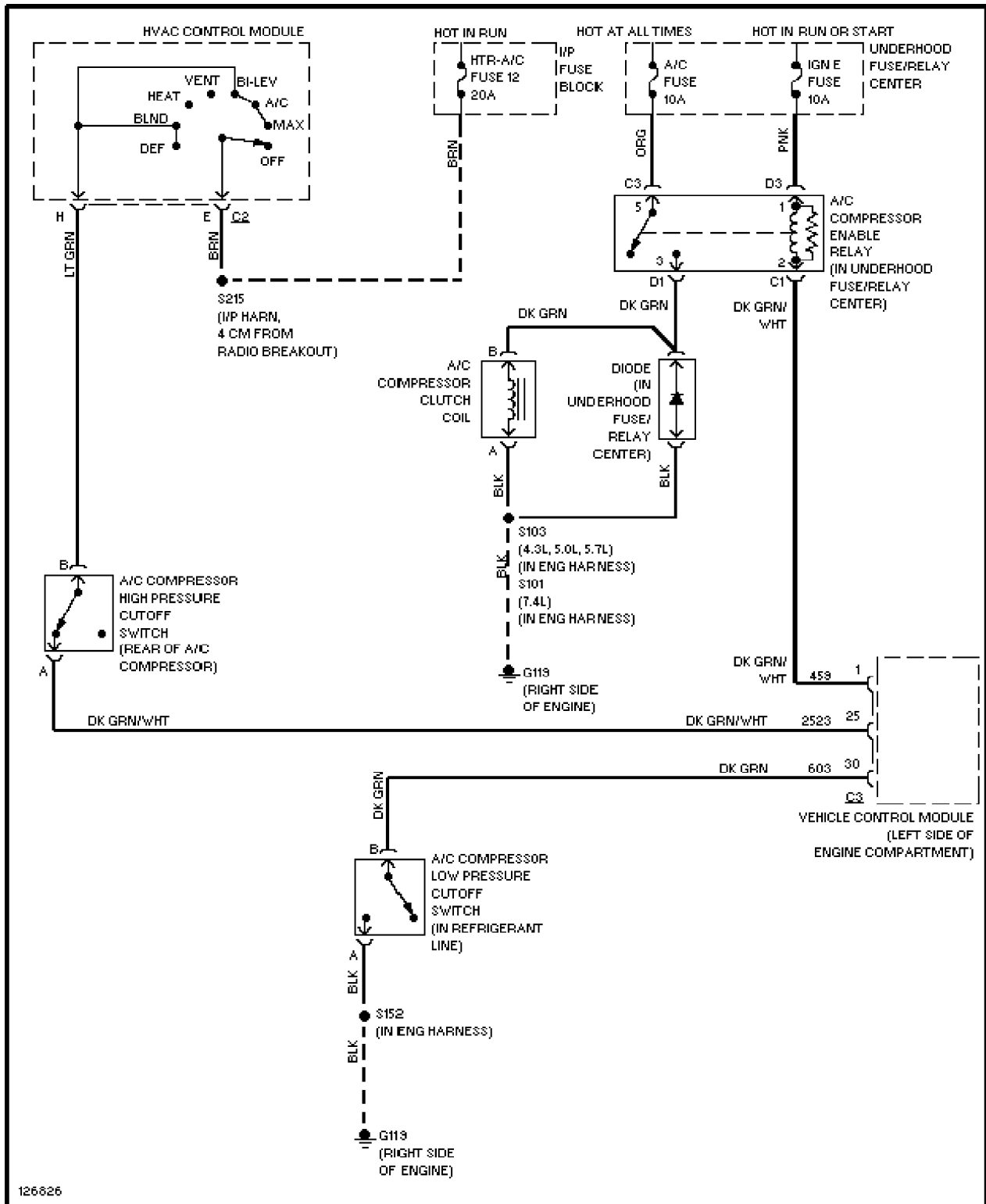

Fig. 17: A/C Compressor Clutch Control Circuit Wiring Diagram (2000 Express & Savana - Except Diesel Engine)

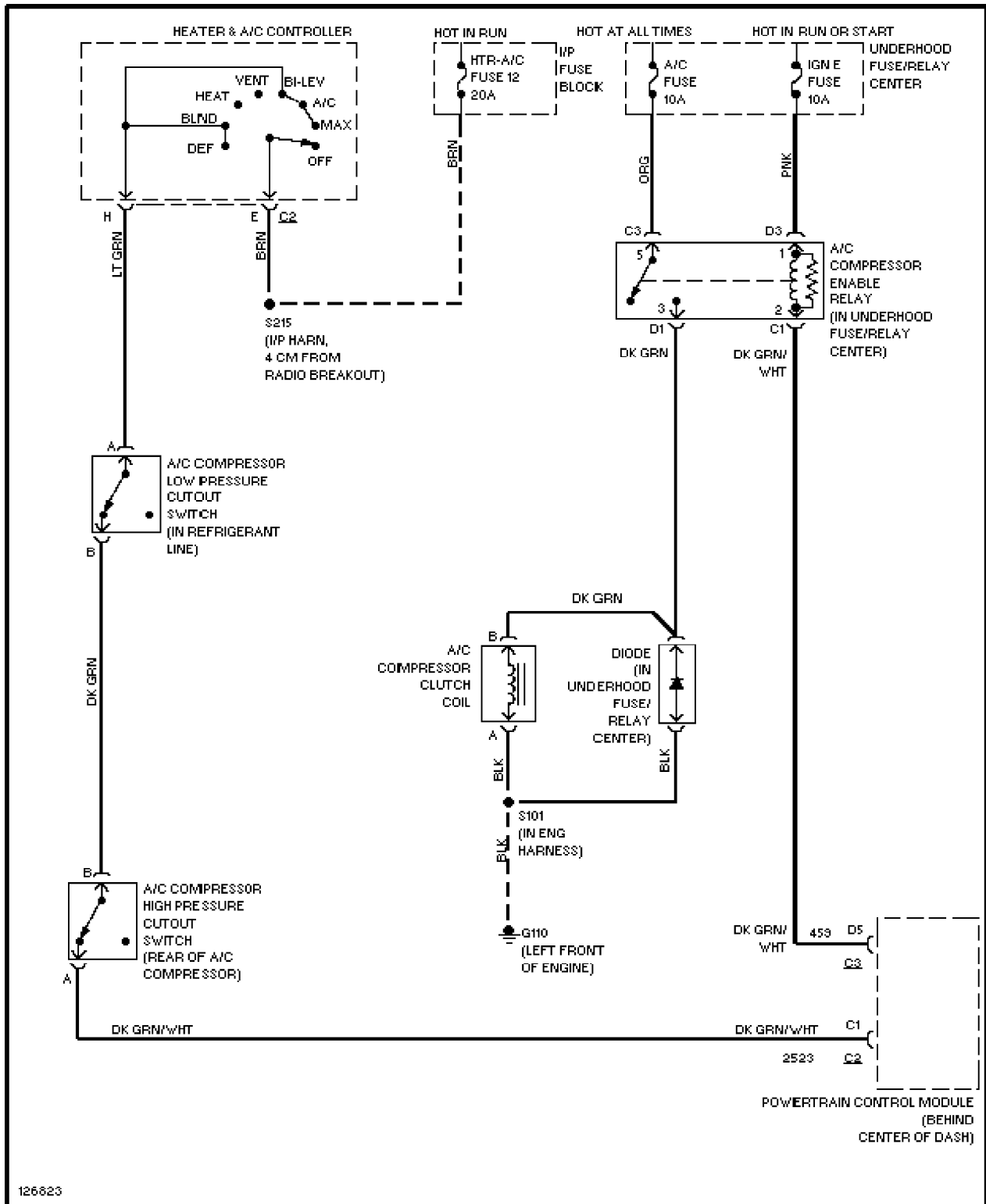

Fig. 18: A/C Compressor Clutch Control Circuit Wiring Diagram (2000 Express & Savana - Diesel Engine)

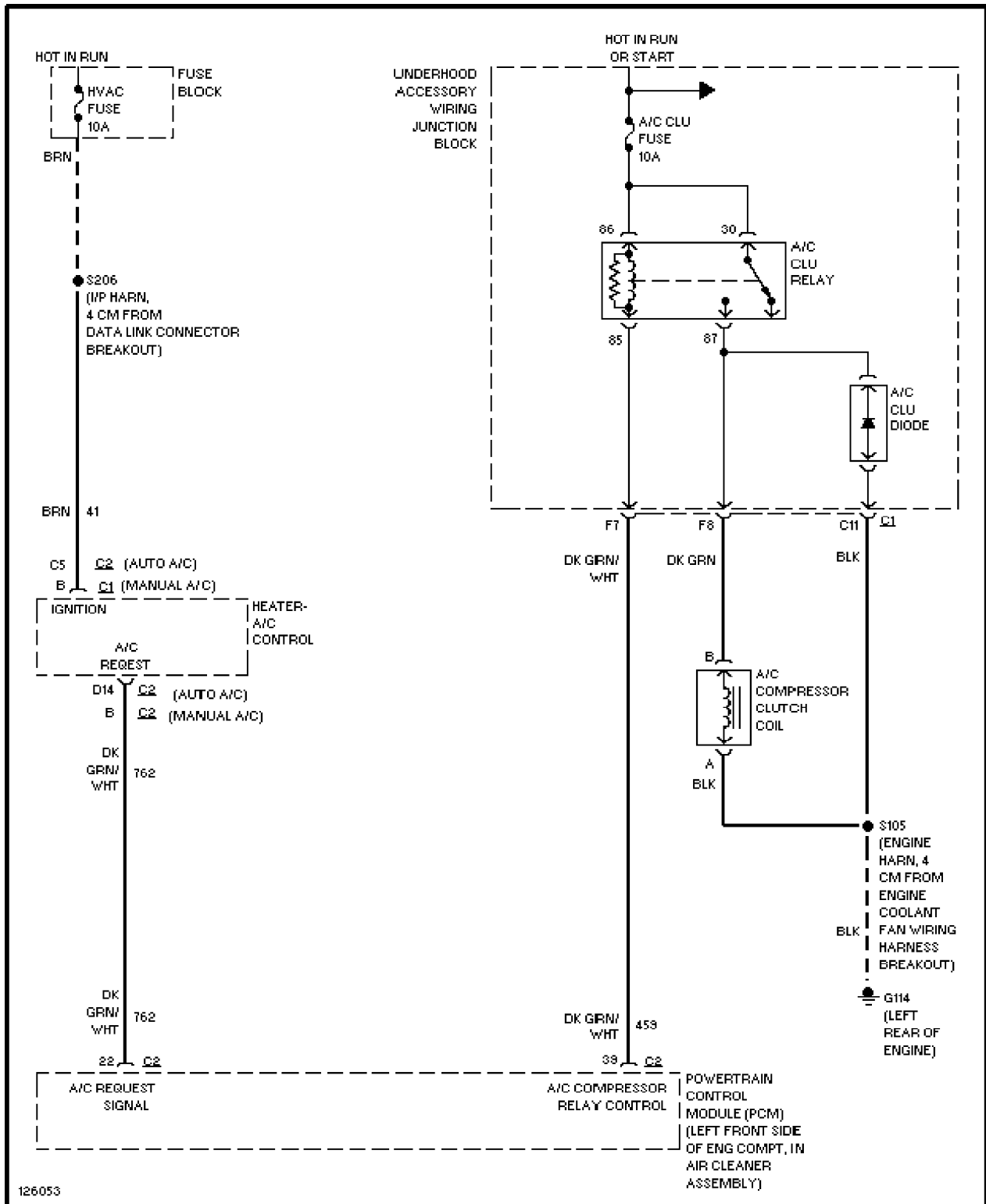

Fig. 19: A/C Compressor Clutch Control Circuit Wiring Diagram (2000 Grand Prix)

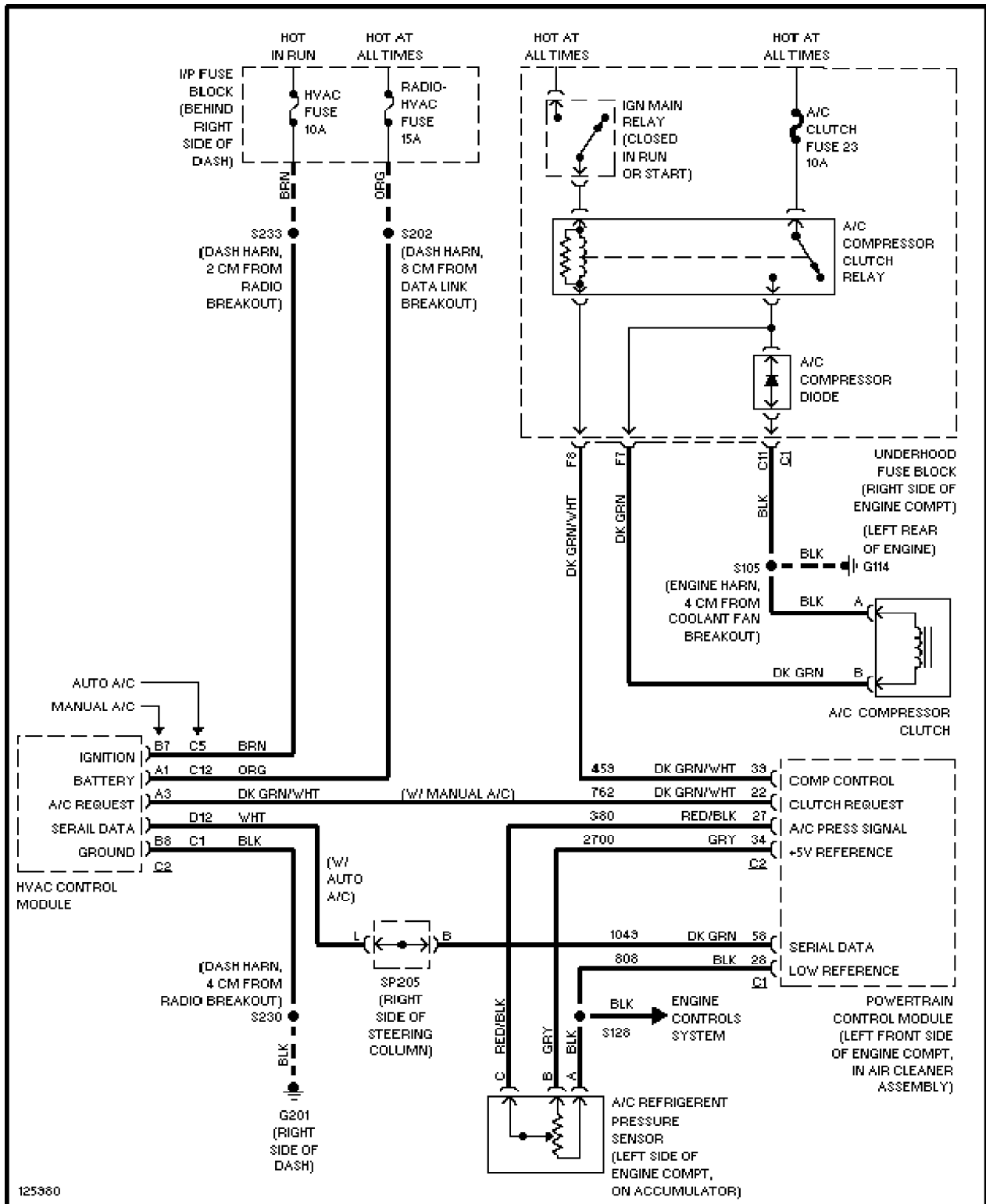

Fig. 20: A/C Compressor Clutch Control Circuit Wiring Diagram (2000-01 Intrigue)

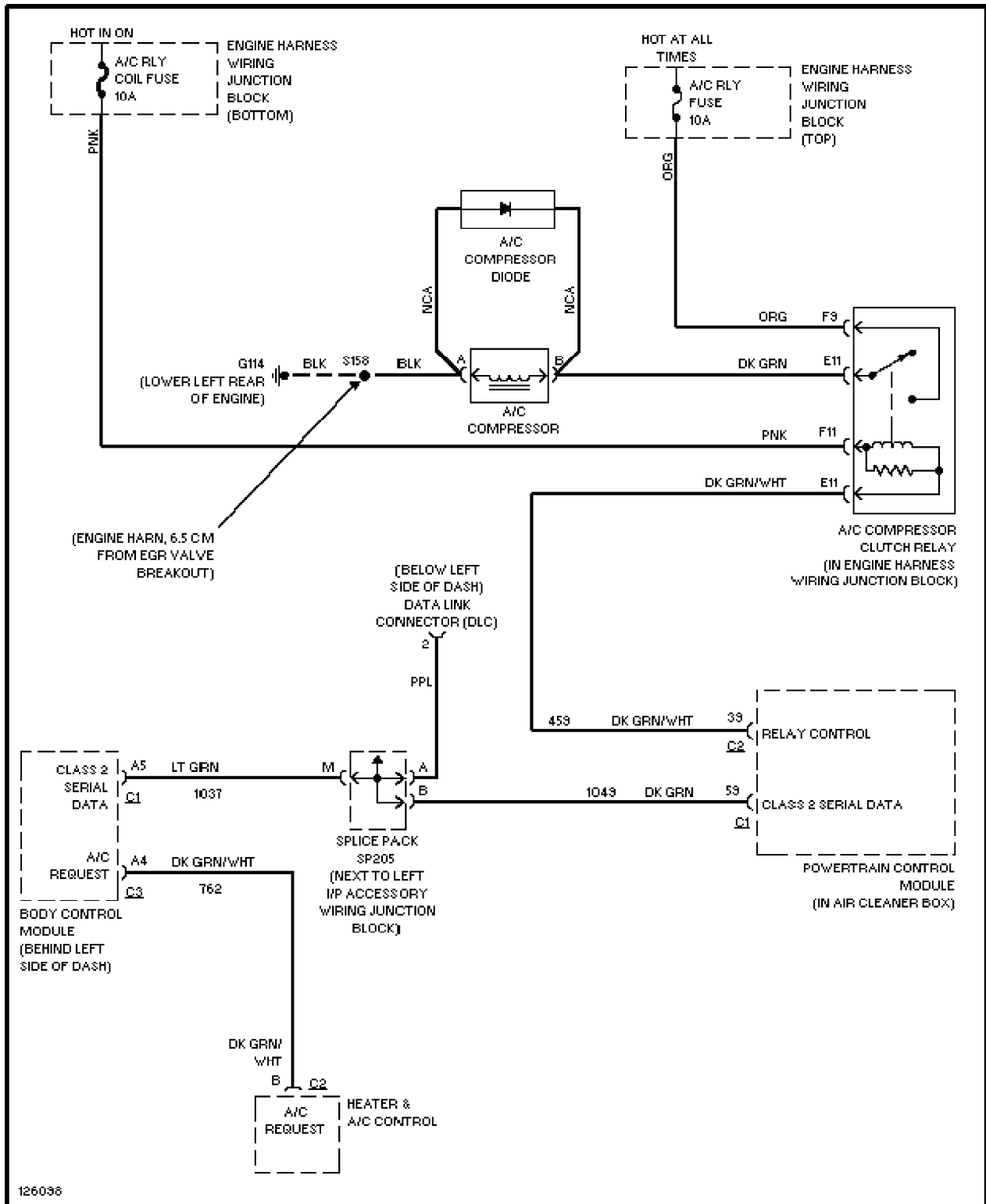

Fig. 21: A/C Compressor Clutch Control Circuit Wiring Diagram (2000 Impala & Monte Carlo)

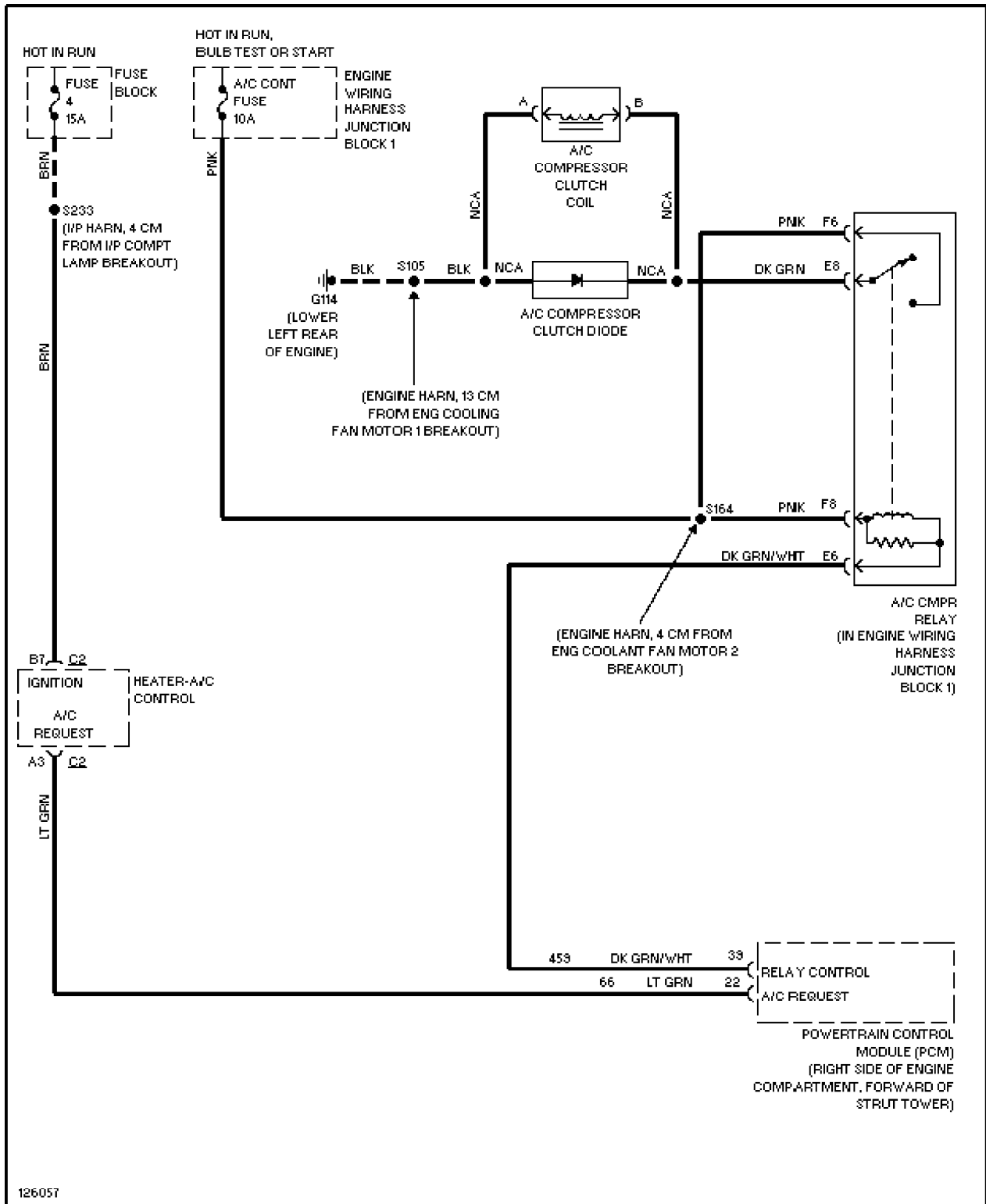

Fig. 22: A/C Compressor Clutch Control Circuit Wiring Diagram (2000-01 Lumina)

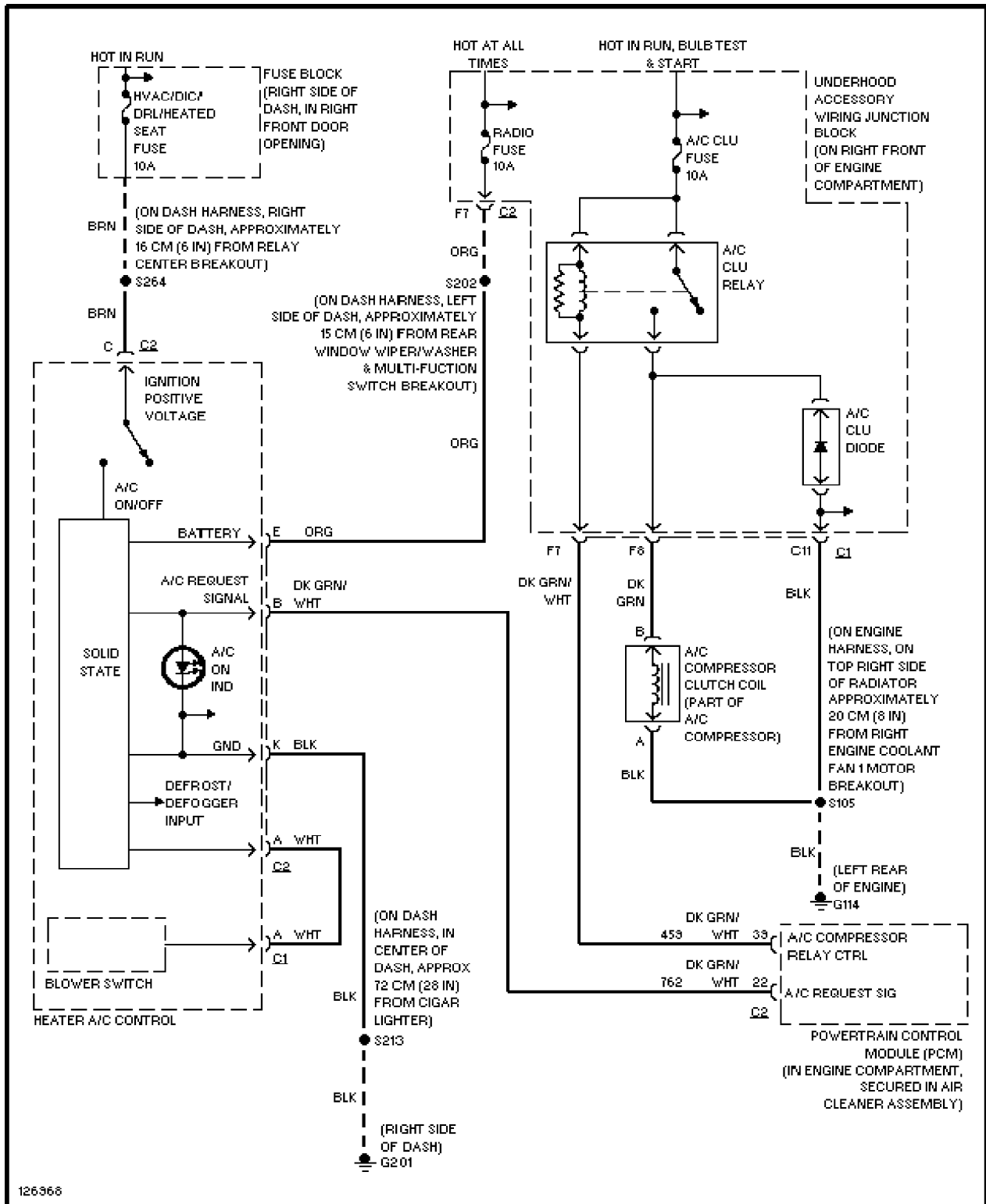

Fig. 23: A/C Compressor Clutch Control Circuit Wiring Diagram
(2000 Montana, Silhouette & Venture)

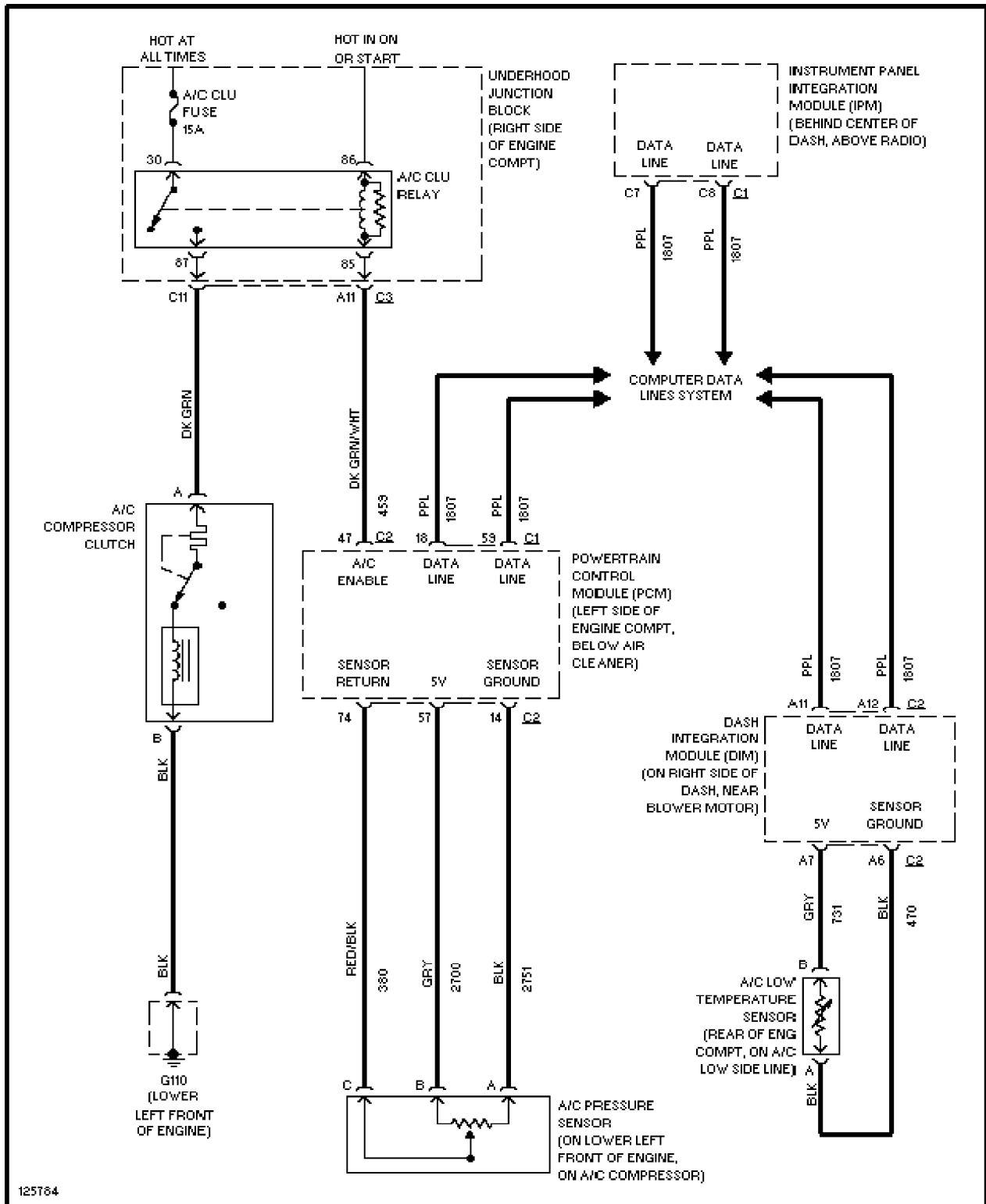

Fig. 25: A/C Compressor Clutch Control Circuit Wiring Diagram (2000-01 Seville)

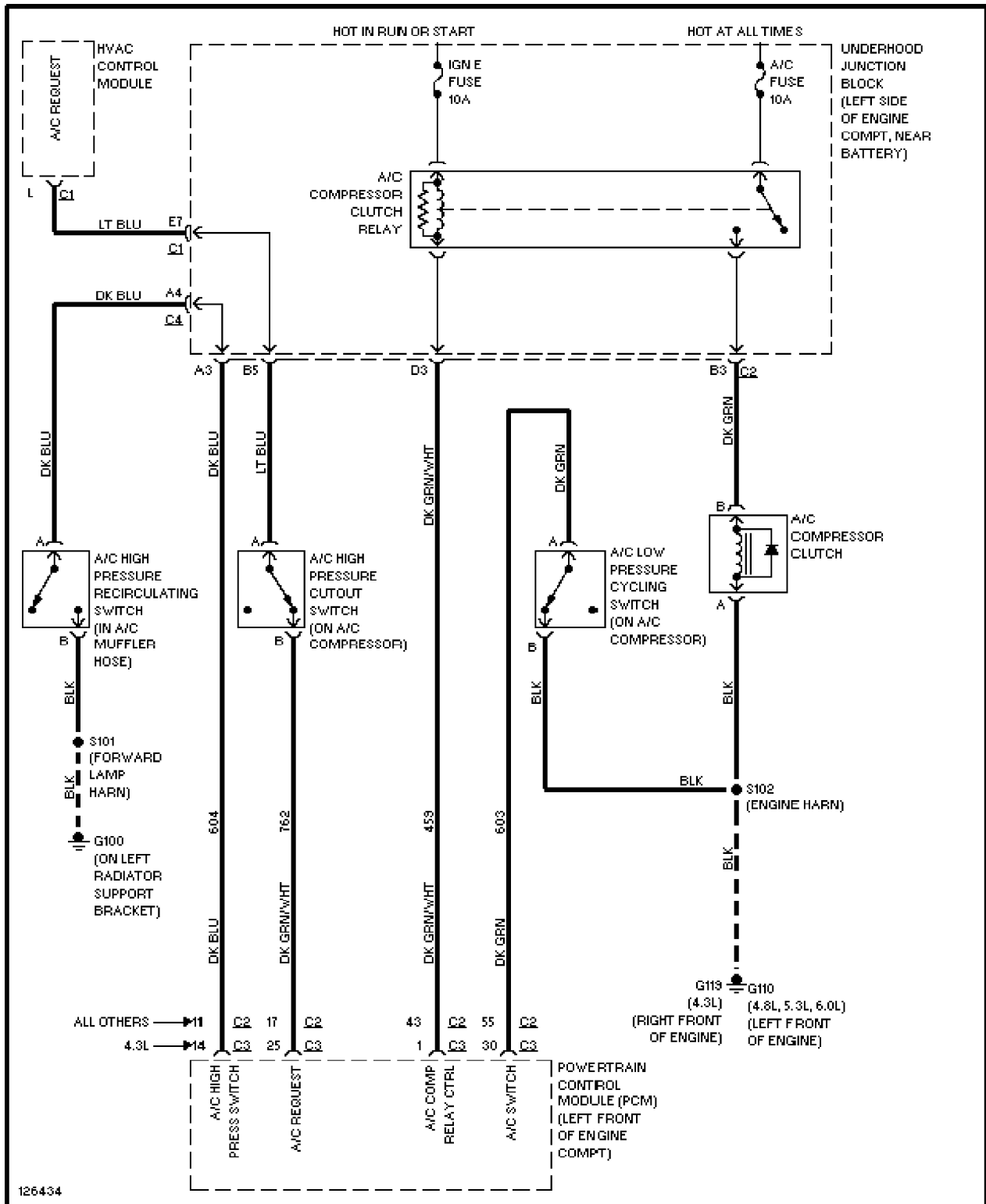

Fig. 26: A/C Compressor Clutch Control Circuit Wiring Diagram (2000-01 Sierra, Silverado, Suburban, Tahoe, Yukon & Yukon XL)

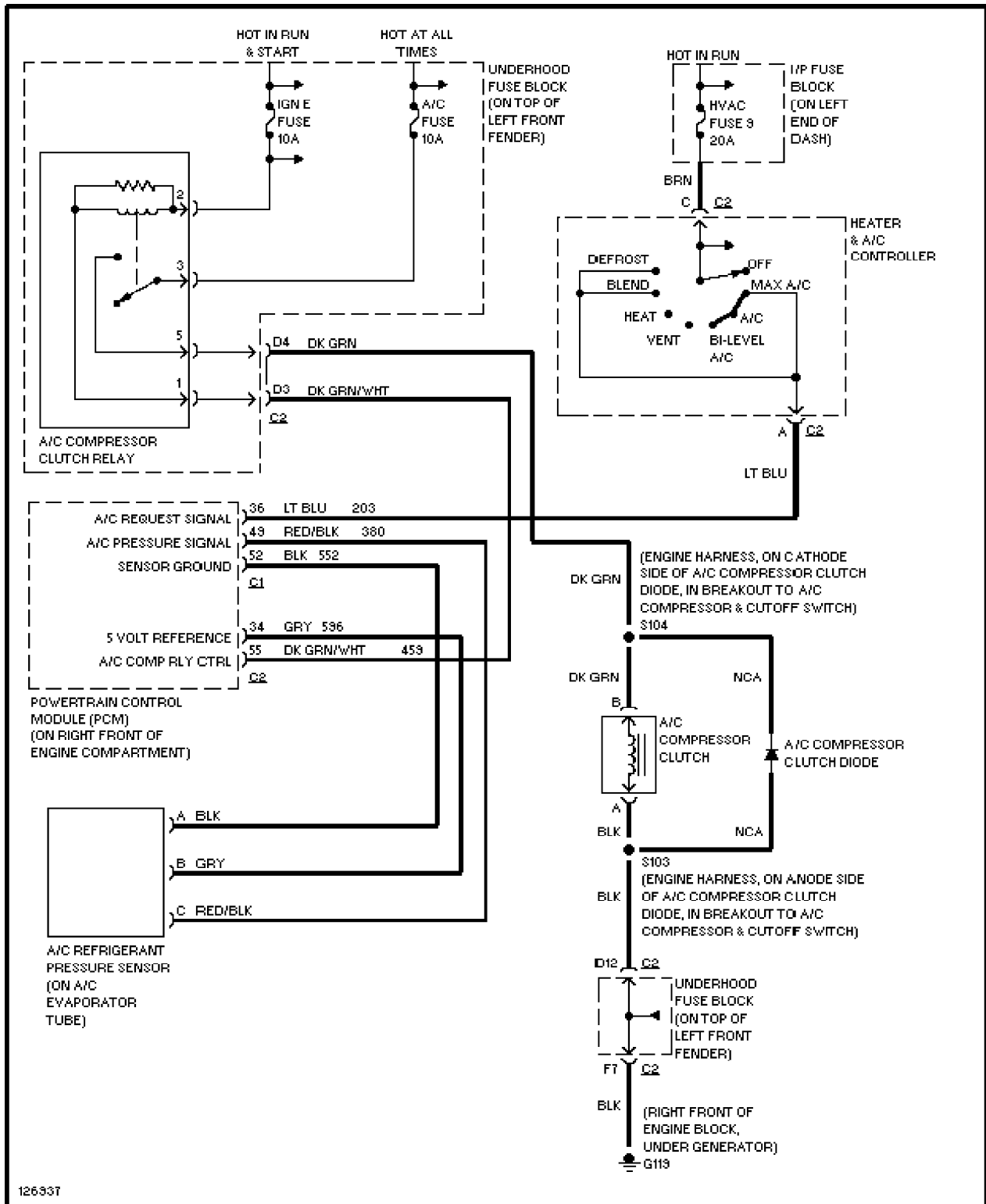
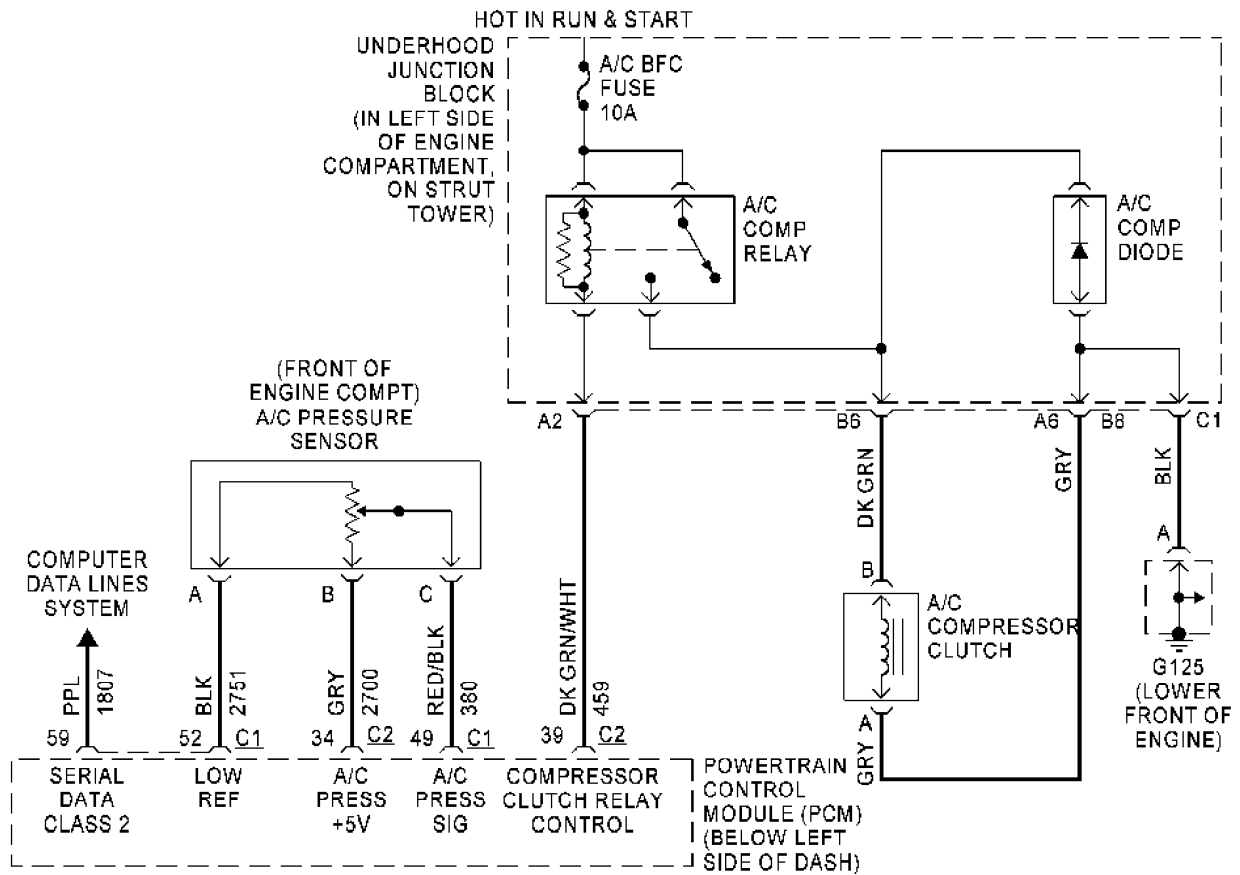
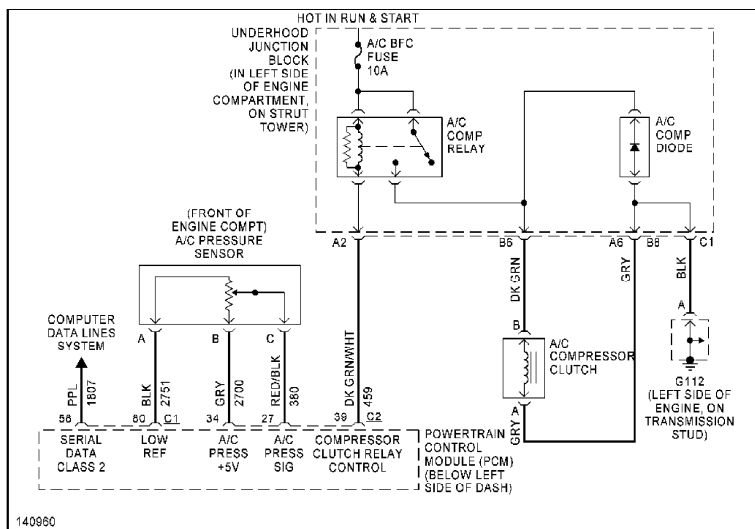

Fig. 27: A/C Compressor Clutch Control Circuit Wiring Diagram
(2000-01 Sonoma & S10 Pickup - 2.2L VIN 4 & VIN 5 Engine)



140961

Fig. 28: A/C Compressor Clutch Control Circuit Wiring Diagram (2001 Alero & Grand Am 2.4L VIN T Engine)



140980

Fig. 29: A/C Compressor Clutch Control Circuit Wiring Diagram (2001 Alero & Grand Am 3.4L VIN E Engine)

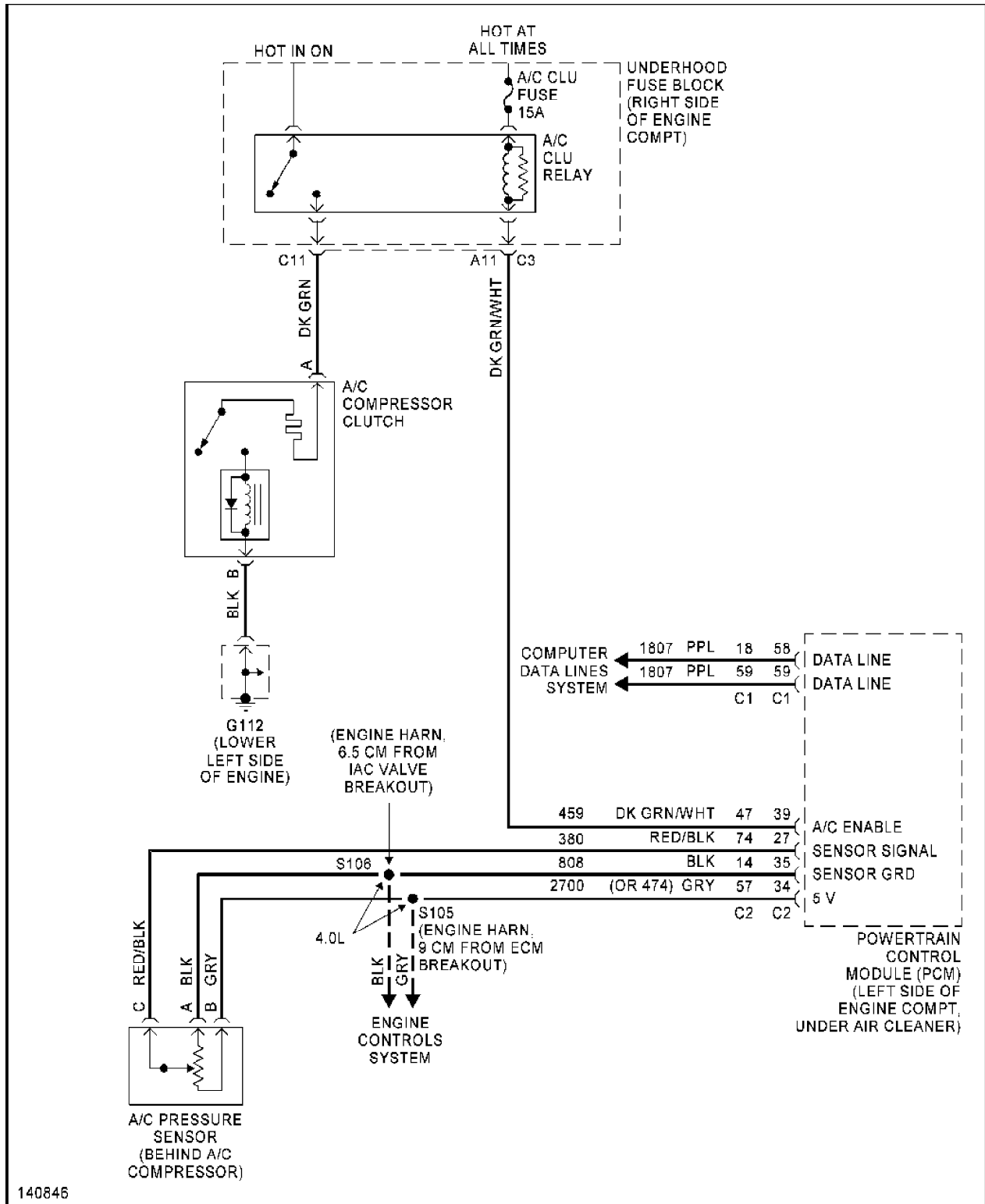

140846

Fig. 30: A/C Compressor Clutch Control Circuit Wiring Diagram (2001 Aurora)

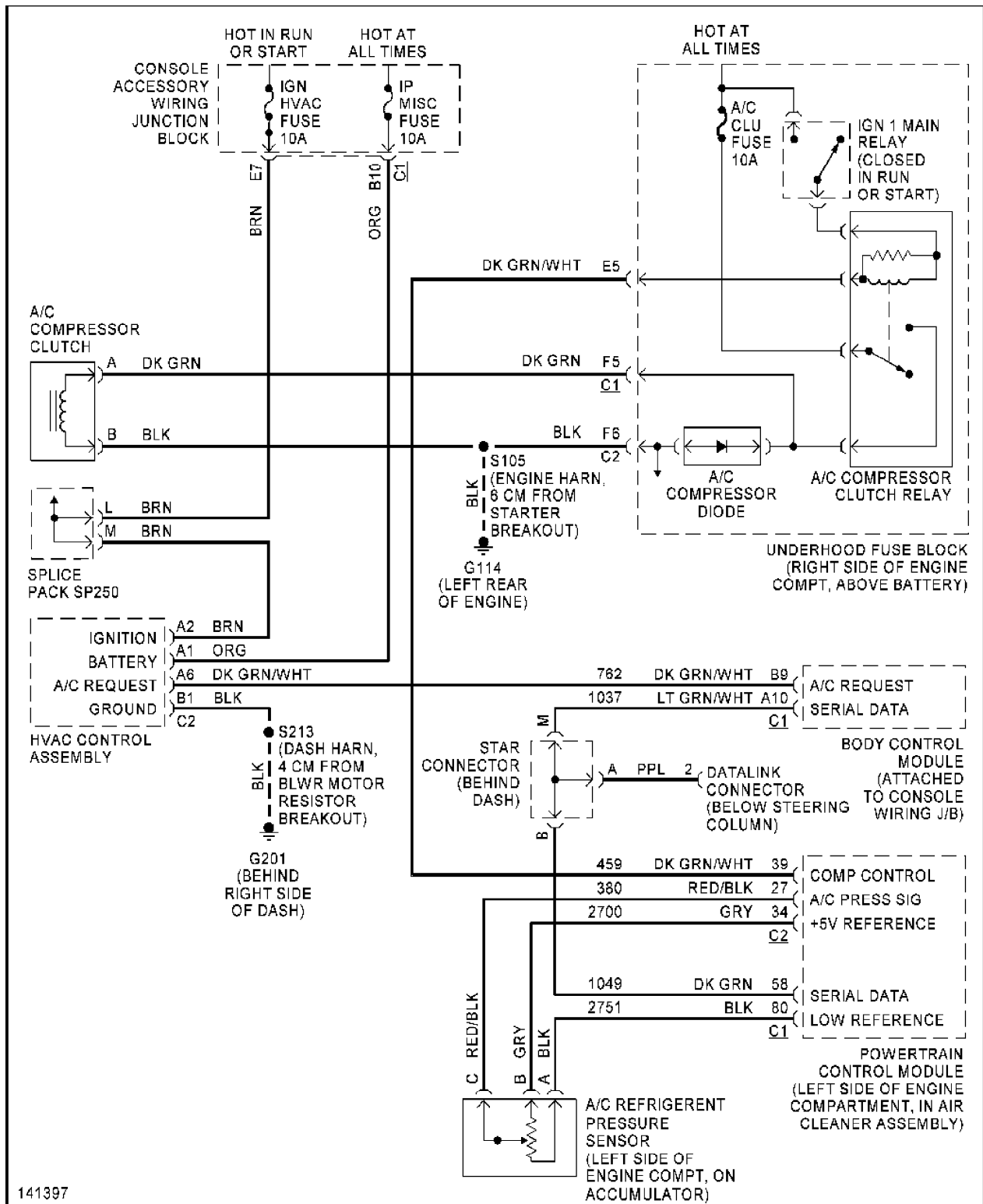

141397

Fig. 31: A/C Compressor Clutch Control Circuit Wiring Diagram (2001 Aztek)

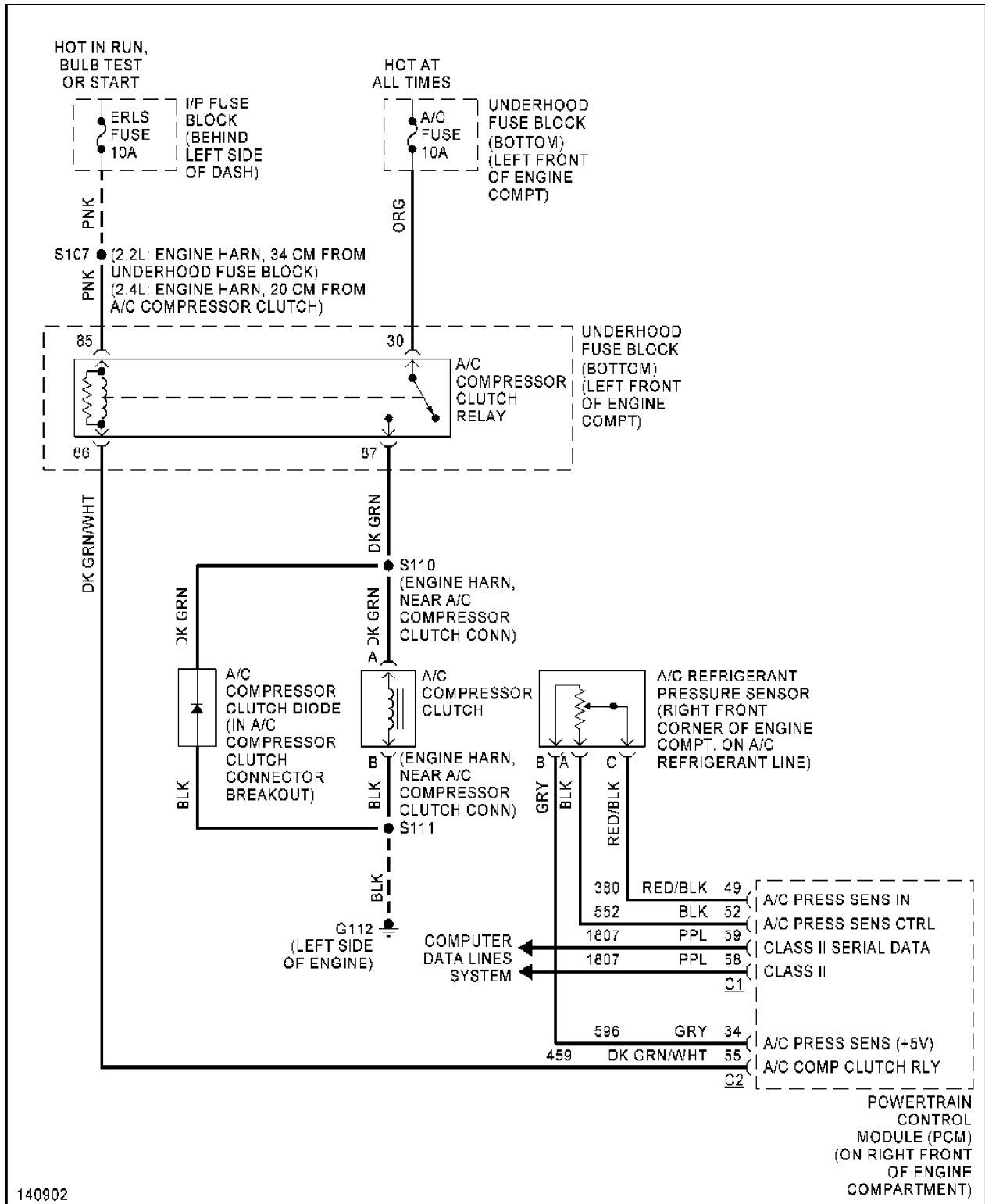

140902

Fig. 32: A/C Compressor Clutch Control Circuit Wiring Diagram (2001 Cavalier & Sunfire)

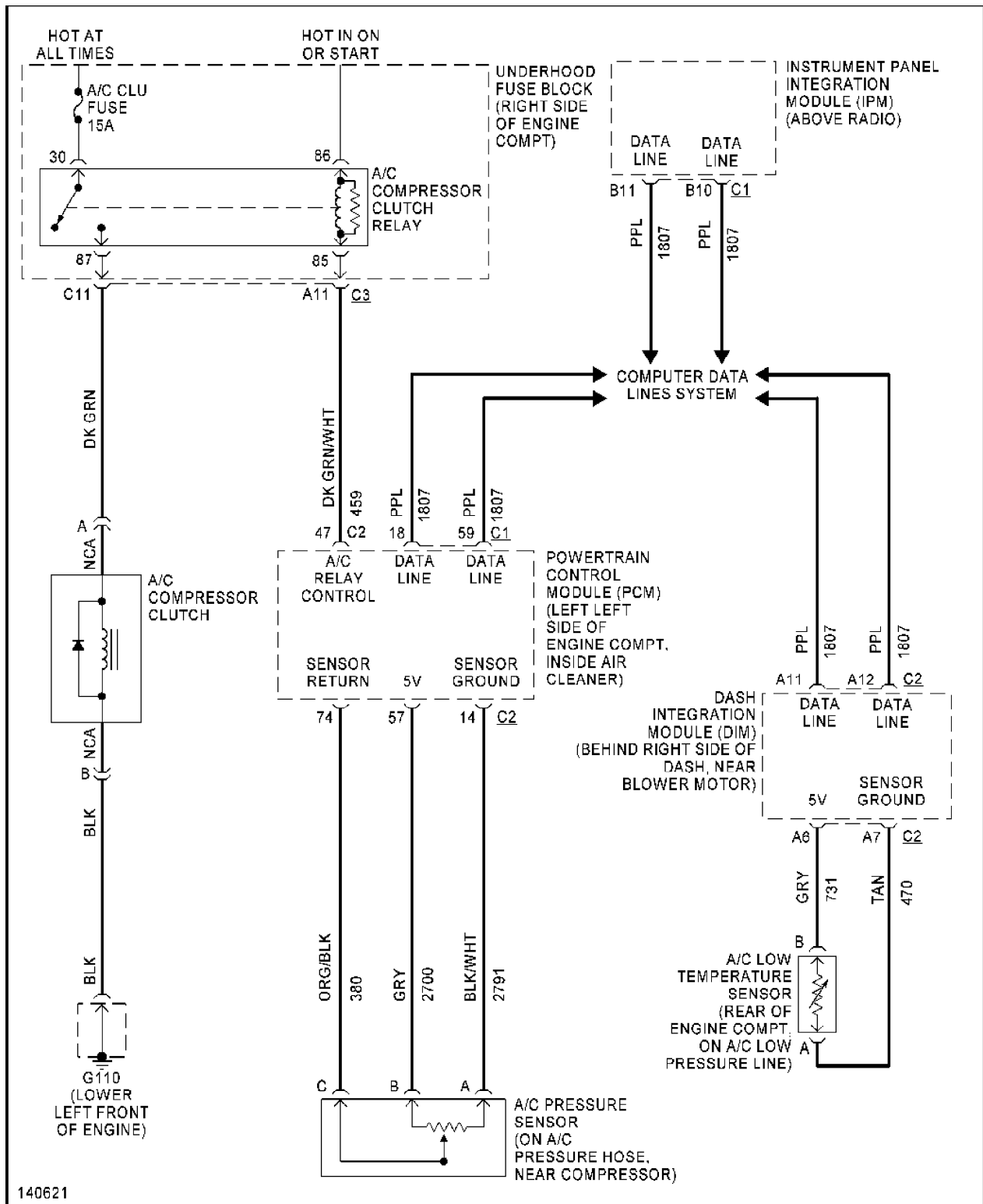

140621

Fig. 33: A/C Compressor Clutch Control Circuit Wiring Diagram (2001 DeVille)

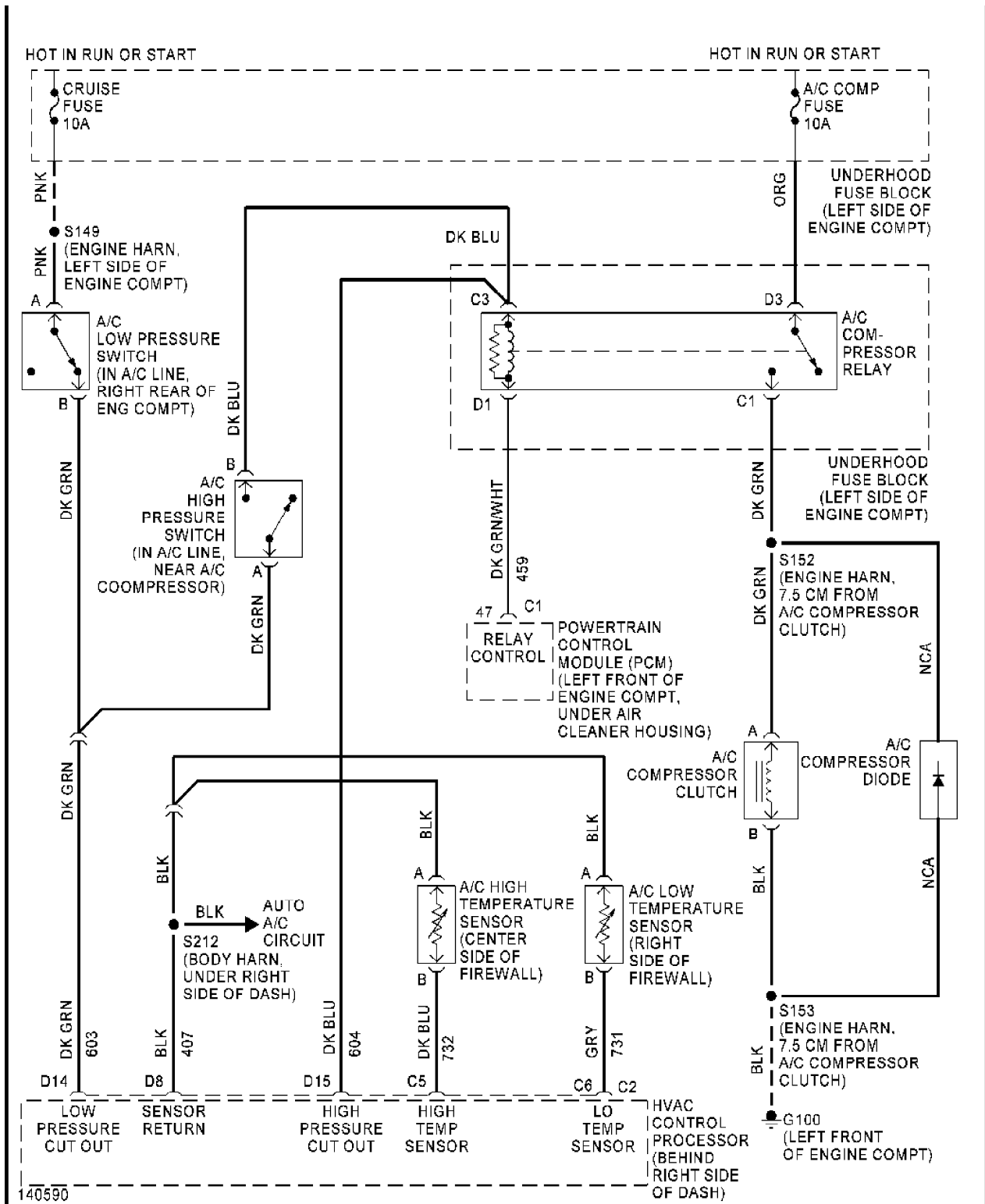
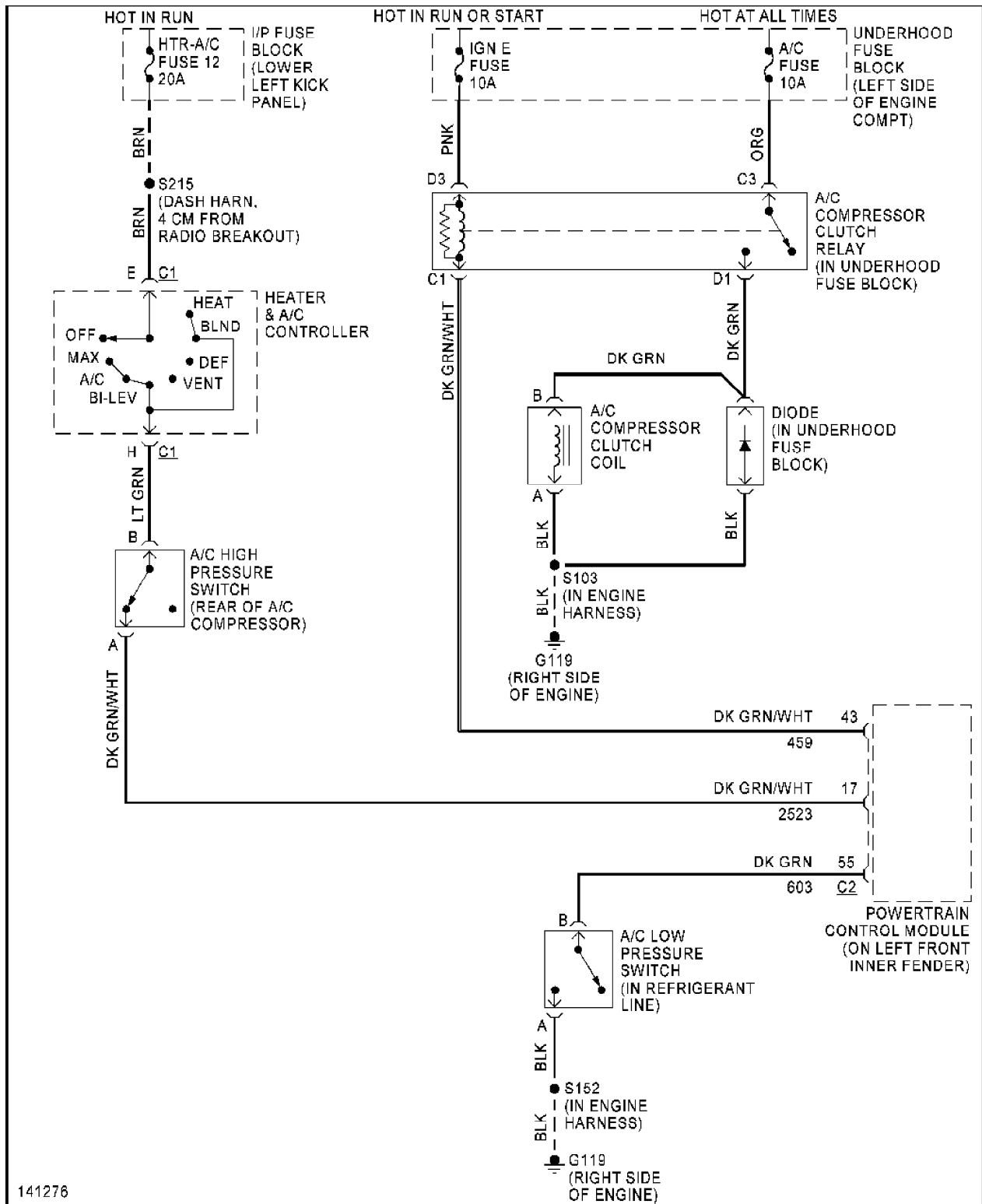
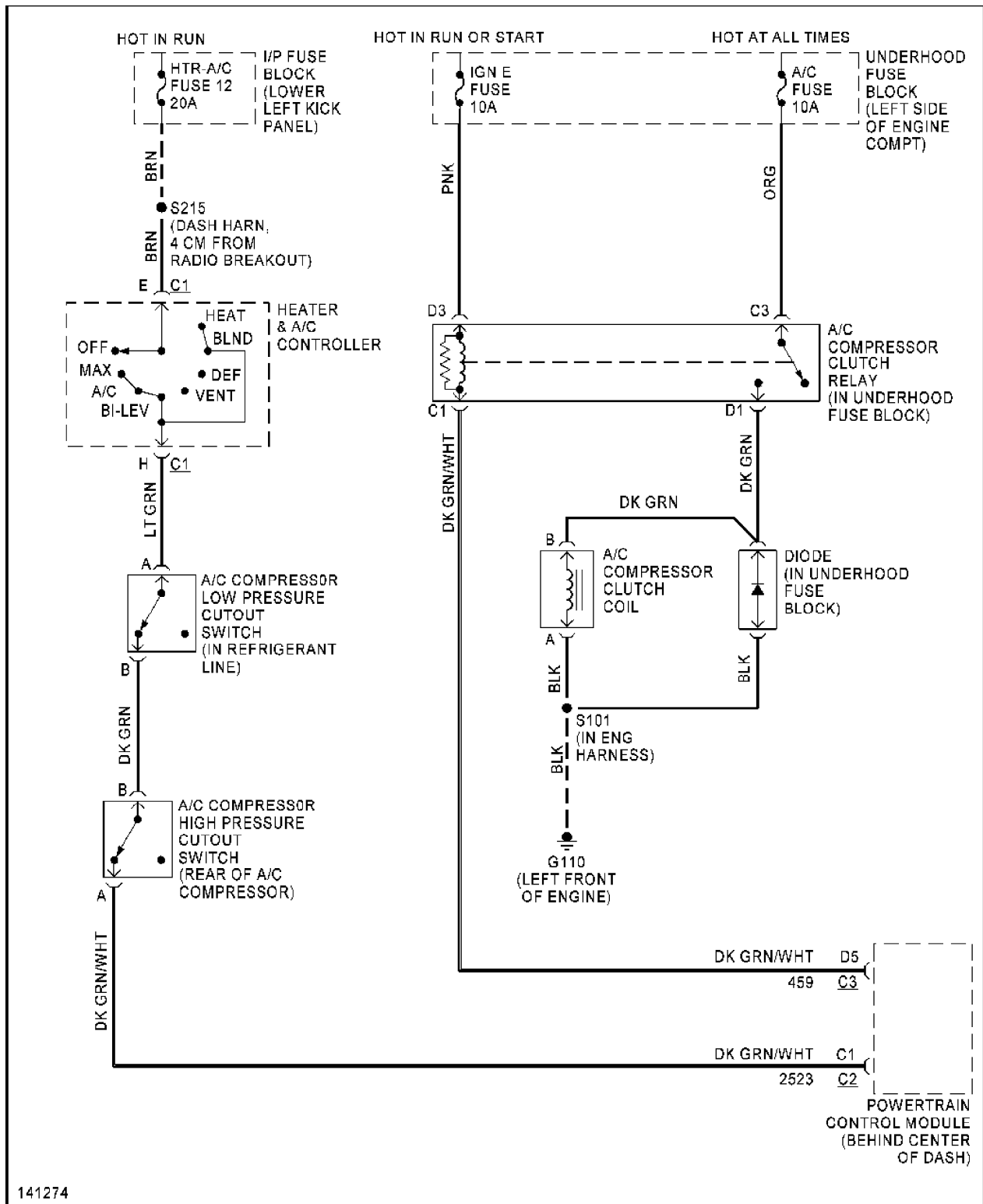

Fig. 34: A/C Compressor Clutch Control Circuit Wiring Diagram (2001 Eldorado)



141276

Fig. 35: A/C Compressor Clutch Control Circuit Wiring Diagram (2001 Express & Savana - Except Diesel Engine)



141274

Fig. 36: A/C Compressor Clutch Control Circuit Wiring Diagram (2001 Express & Savana - Diesel Engine)

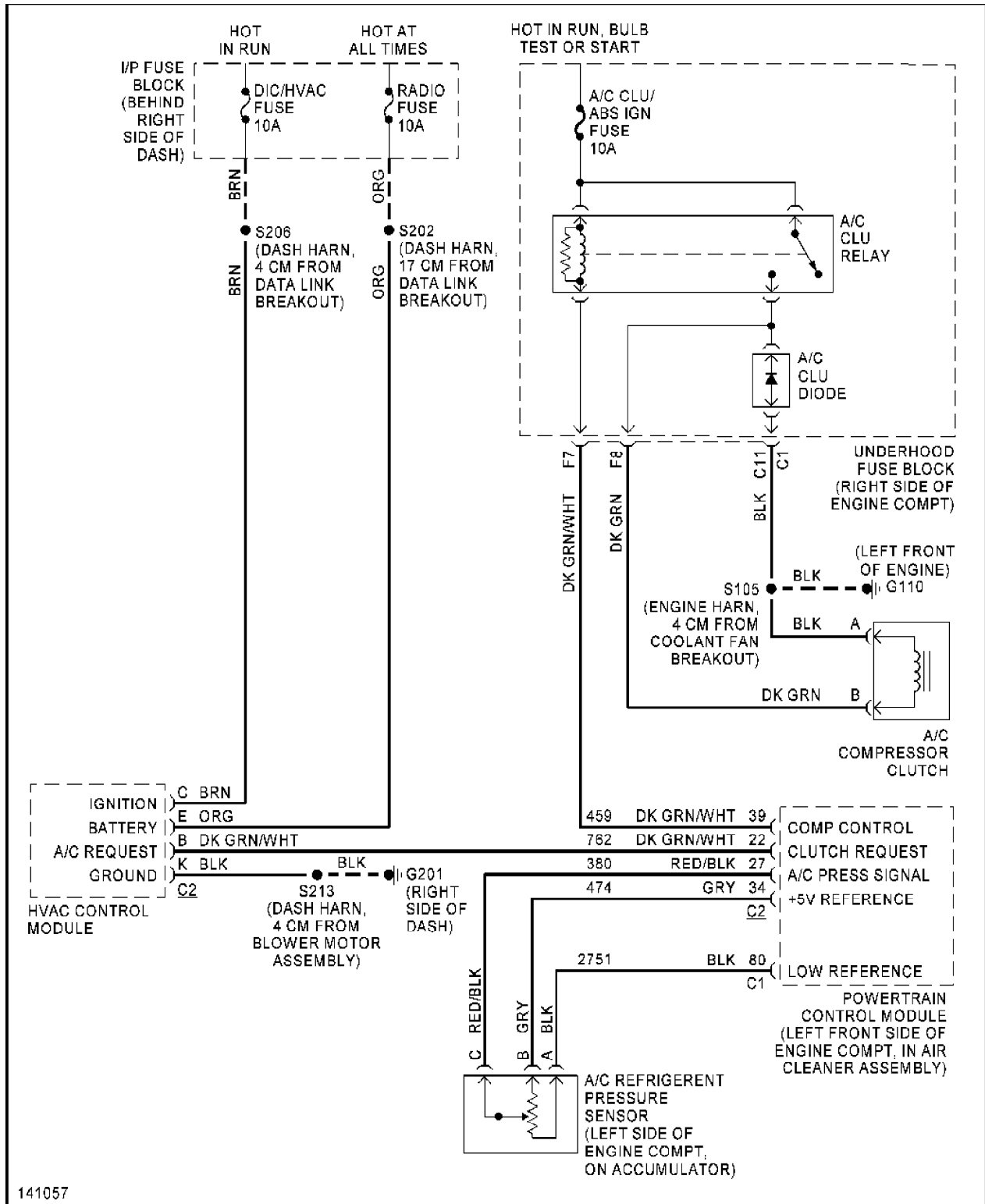

141057

Fig. 37: A/C Compressor Clutch Control Circuit Wiring Diagram (2001 Grand Prix)

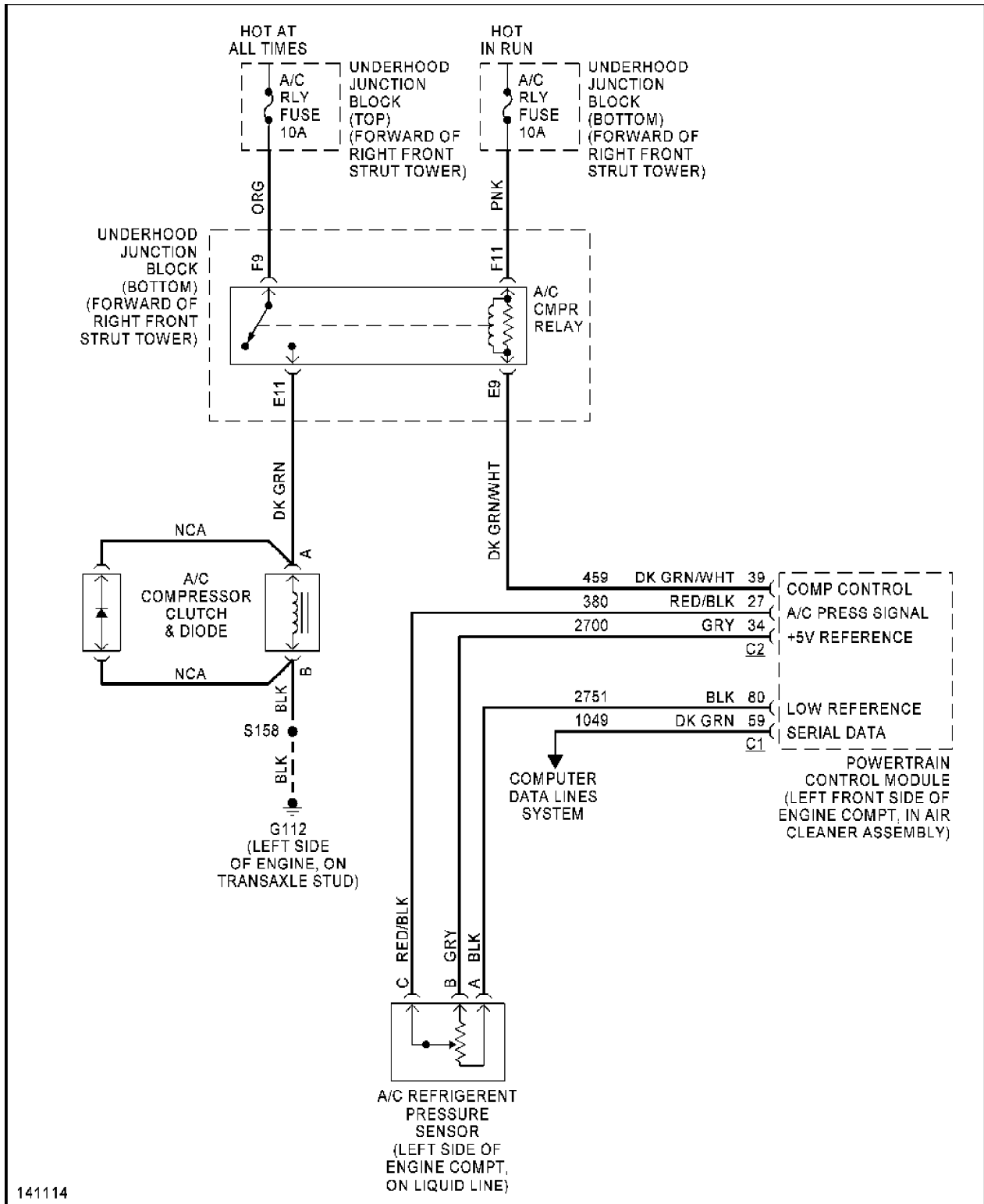

141114

Fig. 38: A/C Compressor Clutch Control Circuit Wiring Diagram (2001 Impala & Monte Carlo)

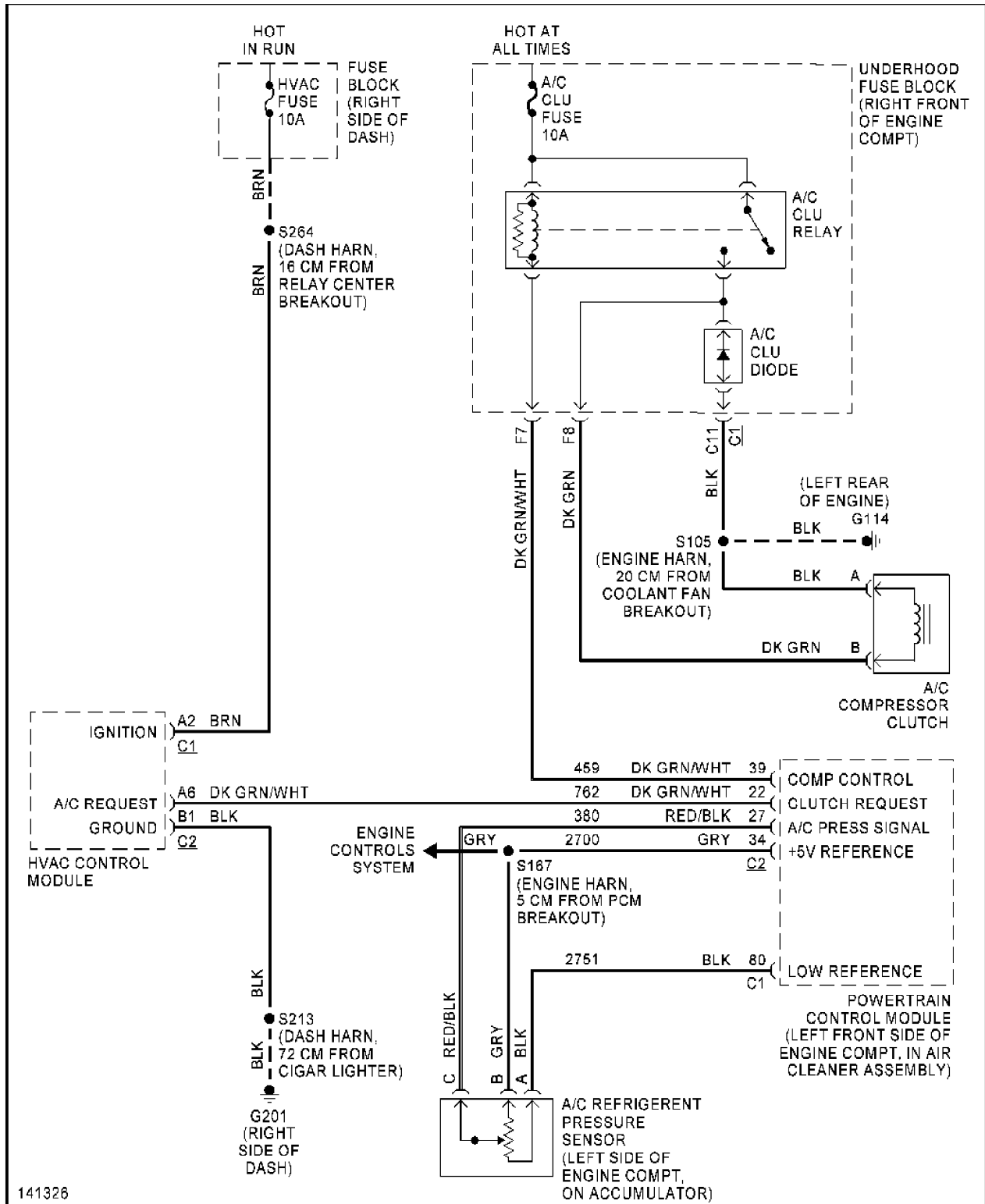

Fig. 39: A/C Compressor Clutch Control Circuit Wiring Diagram (2001 Montana, Silhouette & Venture)

